



ZF Mathers, LLC
1415 Pacific Drive
Burlington, WA 98233 USA
800-546-5455 / 360-757-6265
Fax: 360-757-2500

MicroCommander

314, 580, 585, 585CE and 813

Trouble Shooting

Manual

MM14075 Rev.B 10/01

MicroCommander Trouble Shooting Manual

Table of Contents

MM14075 Rev.B 10/01	1
MicroCommander Trouble Shooting Manual	
Table of Contents	1
Revisions List	1
TRAIN-145 Rev.- 11/00	1
MicroCommander Training Manual Introduction	
1.0 INTRODUCTION - - - - -	1
TRAIN-146 Rev.- 11/00	4
Differences between 314, 580, 585 & 585CE	
2.0 DIFFERENCES BETWEEN 314, 580, 585 & 585CE - - - - -	4
2.1 314 Actuator	4
2.1.1 Most Common Problems.	4
2.2 580 Actuator	4
2.2.1 Most Common Problems.	5
2.3 585 Actuator	5
2.3.1 Most Common Problems.	5
2.4 585CE Actuator - Multi-voltage unit (12- 36 volts).....	5
2.4.1 Most Common Problems.	5
TRAIN-147 Rev.- 11/00	6
MicroCommander Systems in General	
3.0 MICROCOMMANDER SYSTEMS IN GENERAL - - - - -	6
3.1 Control Head	6
Figure 1: 460-2 Control Head Schematic	6
3.1.1 Potentiometer	7
Figure 3: Control Head at Neutral (Right Hand)	7
Figure 2: 460-4 Control Head Schematic	7
Figure 4: Control Head at Full Ahead (Right Hand)	8
Figure 5: Control Head at Full Astern (Right Hand)	8
Figure 6: Control Head at Neutral (Left Hand)	8
3.1.2 Indicator Light	9
3.1.3 Sound Transducer	9
3.1.4 Transfer Button (External & Internal)	9
3.2 ELECTRICAL WIRING	9
3.2.1 Eight-Conductor	9
3.2.2 Power Cable	10
3.2.3 Start Interlock	10
3.3 Push-Pull Cables	10
3.4 Actuator	11
3.4.1 Initialization (Slow Repetitive)	11
3.4.2 Jam (Fast Repetitive)	11
3.4.3 Steady (Continuous)	11

3.4.4 Throttle Feedback Error (Two Short- One Long)	11
3.4.5 Shift Feedback Error (One Short- One Long)	12
3.4.6 Troll Fault (Tone Over Tone)	12
3.4.7 Command Signal Error (Three Short-One Long)	12
TRAIN-148 Rev.- 11/00	13
MicroCommander Synchronization and Trolling Valve	
4.0 SYNCHRONIZATION - - - - -	-13
5.0 TROLLING VALVE - - - - -	-13
Appendix A.1	1
SER-114 Rev.A 3/98.....	1
314 Trouble Shooting (Most Common Failures)	
Figure 1: 314 Circuit	2
SER-123 Rev.A 3/98.....	3
580 Trouble Shooting (Most Common Failures)	
Figure 1: 580 Circuit	4
SER-131 Rev.A 11/00.....	5
585 Trouble Shooting (Most Common Failures)	
Figure 1: 585 Circuit	6
SER-124 Rev.- 1/97	7
MicroCommander Trouble Shooting Guide	
SER-139 Rev.- 1/97	9
Conductor Sizes for 10% Drop in Voltage	
Figure 1: Power Connections	9
SER-104 Rev.A- 7/01	11
585 and 585CE Software Versions	
MMC-309 Rev.D 10/01	15
MicroCommander Software Upgrade SW12705	
SER-143 Rev.- 3/97	17
813 Troll Actuator Trouble Shooting	
Figure 1: 813 Circuit	20
SER-132 Rev.- 1/97	21
813 Trouble Shooting (Most Common Failures)	
MMC-276 Rev.C 7/01	23
Actuator/Processor Circuit Board Replacement Kits	
Figure 1:	24
PROD-062 Rev.C 10/99	25
PROM Change Instructions	
Figure 2:	25

Revisions List

Rev	Date	Revision Description
-	12/00	This Training Manual replaces SER-138 MicroCommander Trouble Shooting Manual.
A	8/01	SER-104 was revised to A
B	9/01	1. Cover Revised to current Standards. 2. Revised TRAIN-145, TRAIN-146, and TRAIN-147 to A. 3. Obsoleted TRAIN-149 adding it to TRAIN-147. Appendix A - Removed MMC-200, SER-126, SER-136, SER-130, TRAIN-089 4. Appendix A - Added MMC-309, MMC-276, PROD-062

1.0 INTRODUCTION

Propulsion Controls

The very first Propulsion Control System can be traced back as far as recorded time. Picture one of those legendary Viking Long Boats with two rows of men, one row on the Port, one on the Starboard. Each row contains 20 men, all rowing in unison to the command of a single voice yelling "row-, row-, row-...." and the crack of the whip when one of those men wasn't doing his part. This is one of the earliest examples of a propulsion control system. The 40 men with their oars are the propulsion system. The single man yelling "row-, row-, row-...." was the first Propulsion Control System for a powerboat.

There have been many variations of Marine Propulsion since then. One thing they all have in common is a need to be controlled in an orderly and safe manner. In the early going, Steam Engines were introduced to marine vessels. Controlling the Steam Engines was done locally by an engineer in the engine room, who had to turn valves and pull levers to change the engines' speed and vessels direction. The Captains orders were relayed to a seaman who would run down to the engine room and pass on the Captain's wishes. This system proved to be very slow and at times, inaccurate. These shortcomings resulted in the introduction of the "Bell Logger" system. In these systems, the Captain's wishes were passed on to the engine room by moving a lever on this device. The Captain could choose, Neutral, ½ Speed, Flank, etc. The pilot house's Bell Logger was connected by wire cables to a similar device in the engine room. Whenever a change in speed or direction was desired, the Bell Logger in the engine room would ring a bell and the requested speed would be pointed to with an arrow. Once the necessary valves were turned and levers pulled, the engine room would acknowledge the changes by moving their Bell Loggers Lever to the corresponding position.

This was a vast improvement over the seaman running back and forth between the pilot house and the engine room, but there was room left for improvement. This need resulted in the first true Remote Propulsion Control system. In this system, there was a direct connection between the pilot house and the engine and gear box. This was typically accomplished using steel wires. These worked well in installations with one or two remote stations or where the distance from the pilot house to the engine room were minimal. However, in installations which required many stations or on large vessels, this system proved to be cumbersome and required much maintenance.

At this time, technology had advanced to the point where pneumatics became a viable medium for controlling engines and gears. These worked very well and still have a strong following today. In addition to just changing engine speeds and selecting clutches, a control system could actually introduce some logic to the sequencing of engine speed and direction. These systems proved to be very valuable to the commercial operators. The wear and tear on the machinery saved by shifting and throttling up and down at the correct times more than paid for themselves. The one draw back encountered by pneumatic

control systems is the initial expense and the fact that the vessel requires a source of air. On larger vessels this did not pose a problem but was a major problem on smaller vessels. This effectively eliminated the pneumatic systems on smaller vessels. For the time being, the mechanical system had to be relied on.

This was the case until 1987. This was the year that the first electronic Propulsion Control system was introduced to the world. At first the electronic controls were met with a lot of skepticism, but quickly gained the trust of both the recreational and commercial boater. This control system was the **MicroCommander Model 42 Actuator**. The MicroCommander provided protection and the ability to add multiple stations, as is found in the pneumatic systems, without the high initial cost and the need for air. The MicroCommander quickly has become the control system of choice on boats in excess of 30 feet or with multiple stations.

All of the MicroCommander systems, from the very first Model 42, to the latest 585CE Actuators, approach Propulsion Control in the same manner. This approach is by way of a "closed loop servo" system. A closed loop servo can be thought of in the following manner:

Compare a MicroCommander system to the heating system in your home. The control system's Control Heads can be compared to the Thermostat mounted to the wall in your dining room. The Actuator compares to the Furnace and the Push-pull cables to the actual heat coming out of the register.

Moving the lever at the thermostat to the desired temperature is like moving the Control Head's lever to the desired speed and direction. When this occurs, an electrical signal is sent from the thermostat to the furnace, which tells the furnace what temperature is desired. The same happens with the MicroCommander system. However, the electrical signal from the Control Head is telling the Actuator what speed and direction is required.

In the heating system in your home, a device internal to the thermostat measures the current temperature and feeds this information back to the furnace. This process is referred to as "feedback". In the MicroCommander, the feedback signal is generated by two feedback potentiometers and represents the current position of the shift and throttle push-pull cables, not heat.

When the desired temperature, as requested at the thermostat, differs from the temperature measured, a change is ordered in the amount of heat produced by the furnace. The MicroCommander measures the present speed and direction against the desired speed and direction. When a difference exists, the Actuator applies power to a DC motor, which repositions the push-pull cable(s).

When the desired temperature is reached, the furnace discontinues producing heat. With the MicroCommander, when the desired speed and direction is reached (push-pull cable positions), power is turned OFF to the DC motor.

Any further variations of the room's temperature from the desired setting will be detected and the furnace will turn ON, to again reach the desired level. The same can be said about the MicroCommander system. Any changes to the commanded positions, as the result of the operator moving the Control Head lever, will cause the Actuator to come to life and reposition the push-pull cable.

The closed-loop system is a major advance from the open loop systems of the past, as is the case in mechanical and pneumatic control systems. In an open-loop system a lever is moved to a certain position and is left there. There is no regard paid to where this position is or if any changes in position occur after the desired level is reached.

The following pages contain information from our earliest MicroCommander systems, to the systems being produced today. These systems are still doing the same basic function as the earliest systems of controlling the propulsion system in an orderly and safe manner. The techniques surely have changed and the efficiency at which this occurs has definitely improved.

TRAIN-146 Rev.- 11/00
Differences between 314, 580, 585 & 585CE

2.0 DIFFERENCES BETWEEN 314, 580, 585 & 585CE

2.1 314 ACTUATOR

The first one was shipped October 1987.

The last one was shipped in July 1990.

Runs on 12 volt supplies. (11- 16 volts acceptable)

Not reversed polarity protected.

Does not have synchronization or troll capabilities.

Serial numbers 00501- 05298.

Replacement circuit boards not available.

The latest Software Version is P/N 01137. (improved jam logic, transfer at any speed, capability for 0 sec. full speed reversal)

2.1.1 Most Common Problems

- Surge Suppressor (SS1) shorted.
- This is caused by voltage in excess of 20 volts or by reversed polarity.
- Open or shorted Mosfet.
- This is caused by mis-adjusted push-pull cable.
- Shorted servo motor
- Once again, push-pull cable adjustment incorrect. New software helps out.
- Micro-Controller socket
- Cannon sockets.
- VCC & VCP capacitors.
- Dip Switch

2.2 580 ACTUATOR

ZF Mathers does not offer repair.

Runs on 12- 16 volts only.

Rev. C

Serial No.'s 05600- 05879. (No synch or troll without modification to circuit.)
Need to run 12 volts to pin 14.

Replacement Circuit Board. (P/N 01037)

Rev. D

Serial No.'s 05900- 08530. (Synch & troll capable)

These Actuators were delivered between September 1990 and April 1992.

Reversed polarity protected. (Diode CR2)

Over voltage protected. (Fuse)

Improved Mosfet heat sink.

Replacement Circuit Board. (P/N 01057)

2.2.1 Most Common Problems

- The majority of the problems were associated with the Rev.C. A modification is required. Change value of fuse from 3/4 amp to 1 amp. Cannon PLCC's.
- The only weakness is the low voltage sensitivity (.7 volts higher then 314).
- Feedback plug connectors (Rev. C).

2.3 585 ACTUATOR

Multi-voltage unit (12-36 volts). In actuality, will run on 8- 40 VDC.

Over-voltage protected (up to 43 volts).

Reversed polarity protected.

Synch & troll capable.

Serial numbers 10000- 22100

These Actuators were delivered from April 1992 through February 1996.

Shunts added for throttle and clutch polarity

2.3.1 Most Common Problems

- Feedback potentiometer problems. Both wiper and terminal resistance.
- Burnt ground trace. Interlock and Mtr Pwr mosfets.
- Surge Suppressor (SS3) shorted.

2.4 585CE ACTUATOR - MULTI-VOLTAGE UNIT (12- 36 VOLTS).

Over-voltage protection (up to 43 volts).

Reversed polarity protection.

Synch & troll capable.

CE marking. Subjected to vibration, salt spray, electromagnetic interference & emissions.

Serial numbers 25000 to 32250 were produced from February 1996 through November 1998 with *black* enclosures

Serial numbers B01001 to B07884 were produced from December 1998 through October 2000 with *white* enclosures

Serial numbers ZB07885 to ZB11700+ were produced from October 2000 to present with *white* Enclosures

First unit shipped February 1996 to present

2.4.1 Most Common Problems

- Serial numbers 25000- 25150 are in the recall range. (Feedback potentiometer)
- No other problems seen at this time

TRAIN-147 Rev.- 11/00
MicroCommander Systems in General

3.0 MICROCOMMANDER SYSTEMS IN GENERAL

All systems have four general components:

1. Control Head(s)
2. Electrical wiring
3. Push- pull cables
4. Actuator

You need to determine which component is malfunctioning. Prior to being able to do this, you must know what is each components responsibility.

Use the Troubleshooting Guide (SER-124).

3.1 CONTROL HEAD

1. The Control Head has four separate circuits. The potentiometer, indicator light, sound transducer, and transfer button.
2. In order to take control at a station, two things must take place. There must be a valid command signal (see Potentiometer, Section 3.1.1) and the Command signal must be taken low (see Transfer Button, Section 3.1.4).

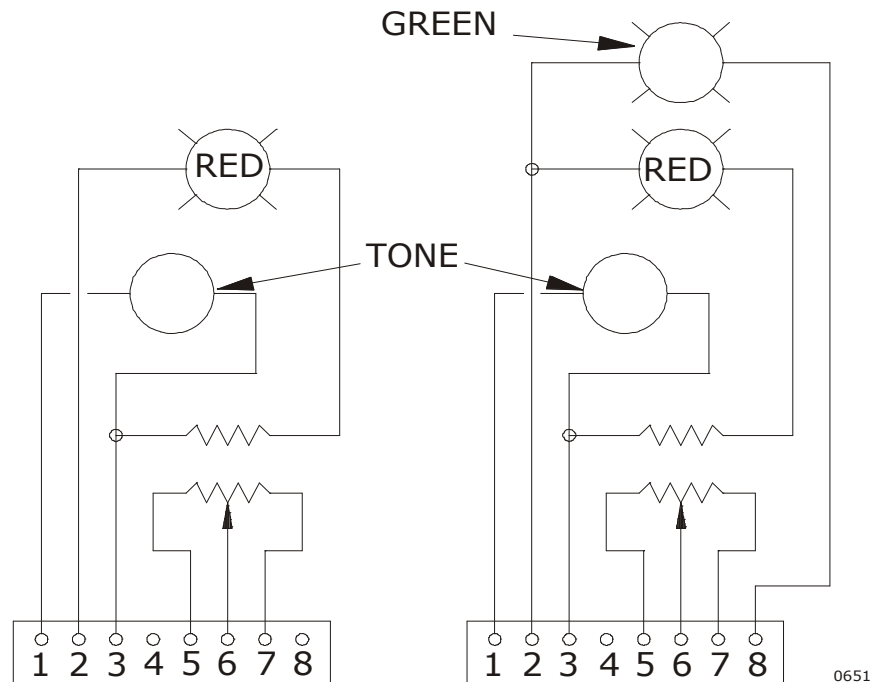

Figure 1: 460-2 Control Head Schematic

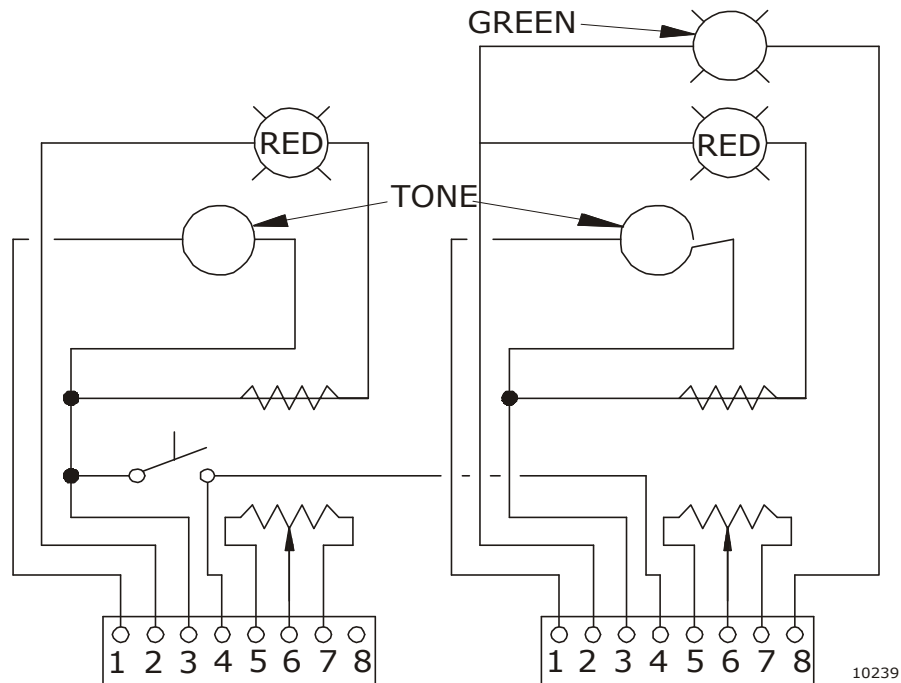

Figure 2: 460-4 Control Head Schematic

3.1.1 Potentiometer

1. The 5 K ohm potentiometer (pot) tells the Actuator when to shift and throttle via the Command Signal which varies when the control head lever is moved.

The Command Signal is the voltage which is read at pins 5 & 6 (yellow & green wires) at the Actuator's station (STA 1 through 5).

2. When the Control Head lever is at the Neutral/Idle position, the voltage at pins 5 & 6 should be 50 percent +/- 2 percent of that measured at 5 & 7 (VREF) (yellow & blue wires). See Figure 3:

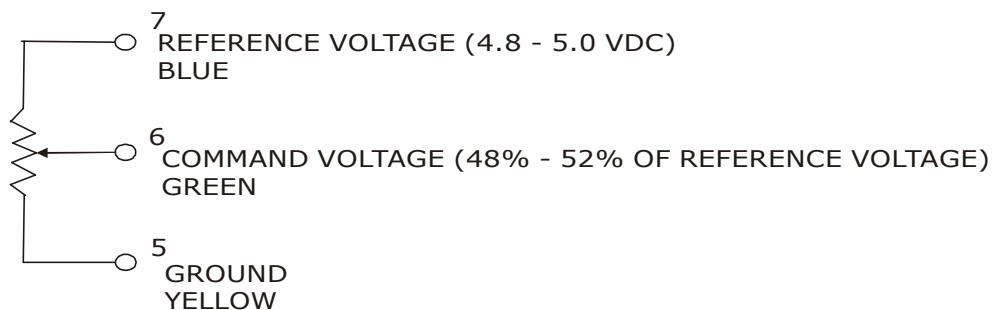

Figure 3: Control Head at Neutral (Right Hand)

3. Control can be taken initially if the voltage at Neutral/Idle is outside of the 50 percent +/- 2 percent. However, the system will be in the throttle only mode (indicator light blinking).

4. Control cannot be transferred to a station which is not at the Neutral/Idle position.
5. A valid command signal is a voltage which is greater than 8 percent and less than 92 percent of VREF. Any voltage outside of this range will cause the Actuator to reset (Neutral/Idle with the slow repetitive tone).
6. The command voltage increases when moving the Control Head lever in the ahead direction and decreases when moving toward astern. See Figure 4: and Figure 5:

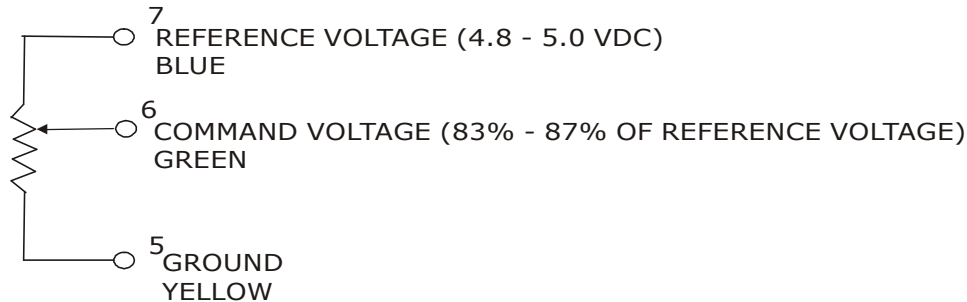

Figure 4: Control Head at Full Ahead (Right Hand)

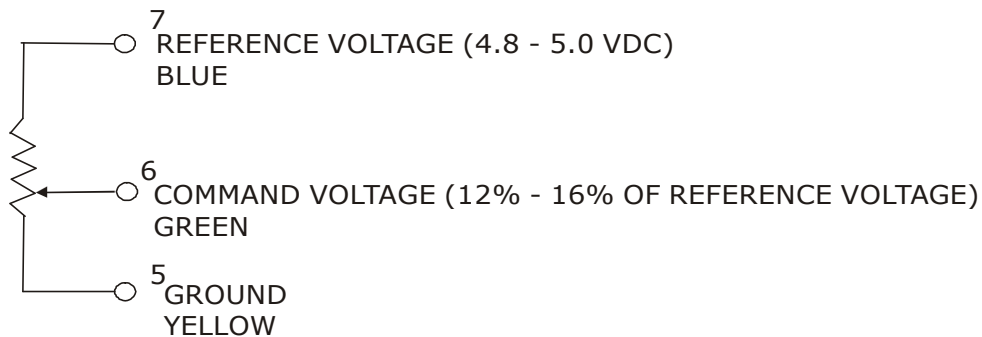

Figure 5: Control Head at Full Astern (Right Hand)

7. The yellow and blue wires are reversed at the control head when configured for left hand. See Figure 6:

YELLOW AND BLUE WIRES REVERSED

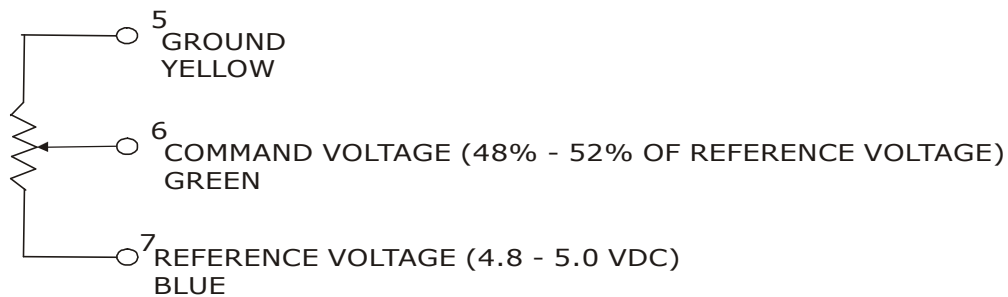

Figure 6: Control Head at Neutral (Left Hand)

3.1.2 Indicator Light

1. Indicates Station-in-Control and Throttle Only Mode when blinking.
2. The voltage supplied to the indicator light can be measured at pins 2 & 3.
3. When the indicator light at a particular station is illuminated, the voltage measured will be the voltage drop across that indicator light (typically 2.20-2.40 VDC).
4. If the indicator light, or the conductor feeding the light, is open the voltage measured will be 3.70- 4.00 VDC.

3.1.3 Sound Transducer

1. The sound transducer emits an audible indication of the System's status or fault condition.
2. The sound transducer signal can be measured at pins 1 & 3. The signal is approximately 1KHz.
3. The amplitude of the signal is between 19- 25 VAC depending on the applied battery voltage.
4. The voltage measured at pins 1 & 3, when no audible tone is present, is 19 - 25 VDC in 585 and 585CE Systems.
5. In 314 and 580 systems, the voltage measured at pins 1 & 3 would be 0 VDC when no audible tone is present.

3.1.4 Transfer Button (External & Internal)

1. The Transfer Button allows control to be taken at a given station and enables other features when depressed.
2. The circuit known as "STASEL" (station select) is normally 5.00 VDC when measured at pins 3 & 4 (red & orange wires).
3. When the transfer button is depressed, the red wire (which is ground) is connected to the orange wire (which is 5.00 VDC). The voltage measured at pins 3 & 4 should go to less than 0.50 VDC.
4. The Starboard (right hand) Control Head connects its orange wire to the Port side's red wire when the transfer button is depressed. This is one reason why the Port and Starboard Actuator's power sources must have a common ground.

3.2 ELECTRICAL WIRING

The wiring consist of the eight-conductor to each Control Head, and the two-conductors for power and start interlock.

3.2.1 Eight-Conductor

1. The eight-conductor cable can mimic a lot of the problems associated with a Control Head.

2. Check the connections for loose, corroded or improperly crimped or terminated conductors.
3. Compare the voltages at the Actuator and the Control Head. Pin for pin they should be the same.
4. Make sure that the shield is terminated at the Actuator pin 8 and nowhere else. It is critical that the shield wire does not come in contact with the frame or any other ground or conductive material.

3.2.2 Power Cable

1. Wire gauge as it relates to length, voltage, voltage drop and current draw should be closely considered. Refer to SER-139 Conductor Sizes for 10% Drop in Voltage. (Refer to Appendix A, page 9)
2. Loose connections, defective relay contacts and circuit breakers can cause substantial voltage drops.

Measure the voltage at the battery and then at the Actuator, the difference should not exceed 250 milli-volts in a 12 volt system.

3. In gasoline engine applications, ignition Noise on the power cable can cause erratic behavior. Insure that the gasoline engines have resistive plugs and or wires.
4. Ferrite beads should be installed on 580 and 585 Actuator's power cable.
5. Ferrite beads are not required on 585CE systems (built into the circuit board).

3.2.3 Start Interlock

1. The purpose is to prevent the starting of the engines when the gear is not at Neutral and no station is in control.
2. The interlock can be bypassed by connecting both conductors to a single terminal.
3. The interlock relay is rated at 30 amperes.

3.3 PUSH-PULL CABLES

1. The throttle or the shift cable can cause the "Jam Alarm" (fast repetitive tone) if mis-adjusted, or if they are binding.
2. The cable can effect the accuracy of the throttle if excessive bends are present (exceeding 270 degrees).
3. May cause hunting of the synchronization if excessive bends.
4. May bind up if the bend radius is too small causing a jam.

3.4 ACTUATOR

All the Actuators consist of the main circuit board and servo motors. The 585CE also has a Dual Servo Driver Circuit under the Main Circuit Board. The Actuator produces various tones to help in diagnosing. Those tones are as follows:

3.4.1 Initialization (Slow Repetitive)

This tone indicates that the system is powered-up, no station is in control, the gear and engine are at Neutral/Idle, and the program is running normally.

This can be an indication of two different problems:

- 1.Momentary low or loss of power to the Actuator.
- 2.The Command Signal from the Station-in-Command is out of range. (Software Versions 01654 and earlier only!).

3.4.2 Jam (Fast Repetitive)

This tone indicates that either the shift or throttle servo was not able to achieve the commanded position.

- 1.The first step is to determine which servo is jammed. Does the problem occur when shifting or changing the throttle position?
- 2.When this is determined, disconnect the push-pull cable from the corresponding lever. Try operating the control again, is the jam tone still present?
- 3.If the tone is present, remove the push-pull cable from the Actuator. Try operating the control is the jam tone still present?
- 4.If the tone is still there, the Actuator is more than likely defective. Double check the power supply before removing.

3.4.3 Steady (Continuous)

This tone indicates three possible faults.

- 1.Low voltage (less than 8 volts) at the Actuator.
- 2.Component failure.
- 3.Throttle feedback potentiometer terminal resistance fault. This is the only steady tone fault which can be cleared by moving the Control Head lever.

3.4.4 Throttle Feedback Error (Two Short- One Long)

This indicates a fault with the throttle feed back potentiometer. This fault can be recovered from by depressing the transfer button twice. This is a "get home" feature only. The Actuator should be serviced at the first opportunity.

3.4.5 Shift Feedback Error (One Short- One Long)

This indicates a fault with the shift feedback potentiometer. As with the throttle feedback error, this can be recovered from by depressing the transfer button twice.

3.4.6 Troll Fault (Tone Over Tone)

This indicates that the Troll Actuator (00813) has a fault or is not powered-up.

3.4.7 Command Signal Error (Three Short-One Long)

This indicates that the Command Signal from the Station-in-Command went out of range. (Software Version SW12705.0 & higher).

TRAIN-148 Rev.- 11/00

MicroCommander Synchronization and Trolling Valve

4.0 SYNCHRONIZATION

Refer to SER-105 Trouble Shooting Synchronization Hunting Problems - 585 Actuator, and SER-130 585 Trouble Shooting Synch Applications.

5.0 TROLLING VALVE

Refer to SER-132 813 Trouble Shooting most Common Failures.



APPENDIX A.1

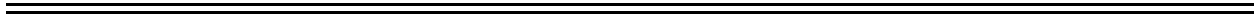



314 Trouble Shooting (Most Common Failures)

FAILURE	CAUSE	SYMPTOM(s)
SSI Shorted	Excessive Voltage or Reversed Polarity	a) No Control b) No Tones c) No Lights lit d) Trips the circuit breaker
Bad Servo Motor	Improperly set push-pull cable throws	a) Either the throttle or shift won't extend and retract (High repetitive tone) b) Burnt Mosfets c) Servo drives slowly (possibly low battery voltage) d) Trips circuit breaker when servo drive called for
Bad Mosfet	Shorted Servo Motor Electrostatic discharge	a) Servo won't drive in one direction (High repetitive tone) b) Trips circuit breaker
Start Interlock Traces Burnt	Start Interlock current exceeded 10 amps	Cannot start the engine when controls are 'ON' and in Neutral

TECHNICAL TIPS

- The 314 Actuator requires 12 VDC - 16 VDC for proper operation.
- When power is initially applied, the servos drive to Neutral and Idle. Lights L1, 2, and 3 should be illuminated. L4 should be flashing at the rate of the tone.
- When the transfer button is depressed, L4 should go solid.
- A High repetitive tone indicates that a servo cannot get to a commanded position. Disconnect push-pull cables first, to insure they are not binding.
- A solid tone indicates a component failure or low voltage. Check voltage first. Make note of lights status.
- Due to the method which the circuit board is mounted to the frame, replacement circuit boards are not available. The whole Actuator must be returned for repair.

314 TEST POINTS AND LEDs

TEST POINT	INDICATION	EXPECTED READING
TP2	VCC (5 volt supply)	4.8 VDC - 5.1 VDC
TP5	Digital Ground	0 VDC
TP7	VCP (5 volt supply)	4.8 VDC - 5.1 VDC
TP8	Voltage Doubler	8 VDC - 10 VDC above battery voltage
TP9	Audible Alarm	1 kHz 20 V. P-P during tone
TP10	Oscillator Output	1 kHz 10 V. P-P
TP11	Clock	4 MHz 5 V P-P
TP12	Reset	4.8 VDC - 5.1 VDC

LIGHT	INDICATION	COMMENTS
L1	VCC (5 volt supply)	
L2	VCP (5 volt supply)	
L3	Voltage Doubler	
L4	Watch-Dog	
L5	Station #1 Control	
L6	Station #2 Control	Shift Feedback Error w/tone
L7	Station #3 Control	
L8	Station #4 Control	Throttle Feedback Error w/tone
L9	Station #5 Control	
L10	Throttle Servo Extend	
L11	Throttle Servo Retract	
L12	Shift Servo Extend	
L13	Shift Servo Retract	
L14	HI - LO Idle	

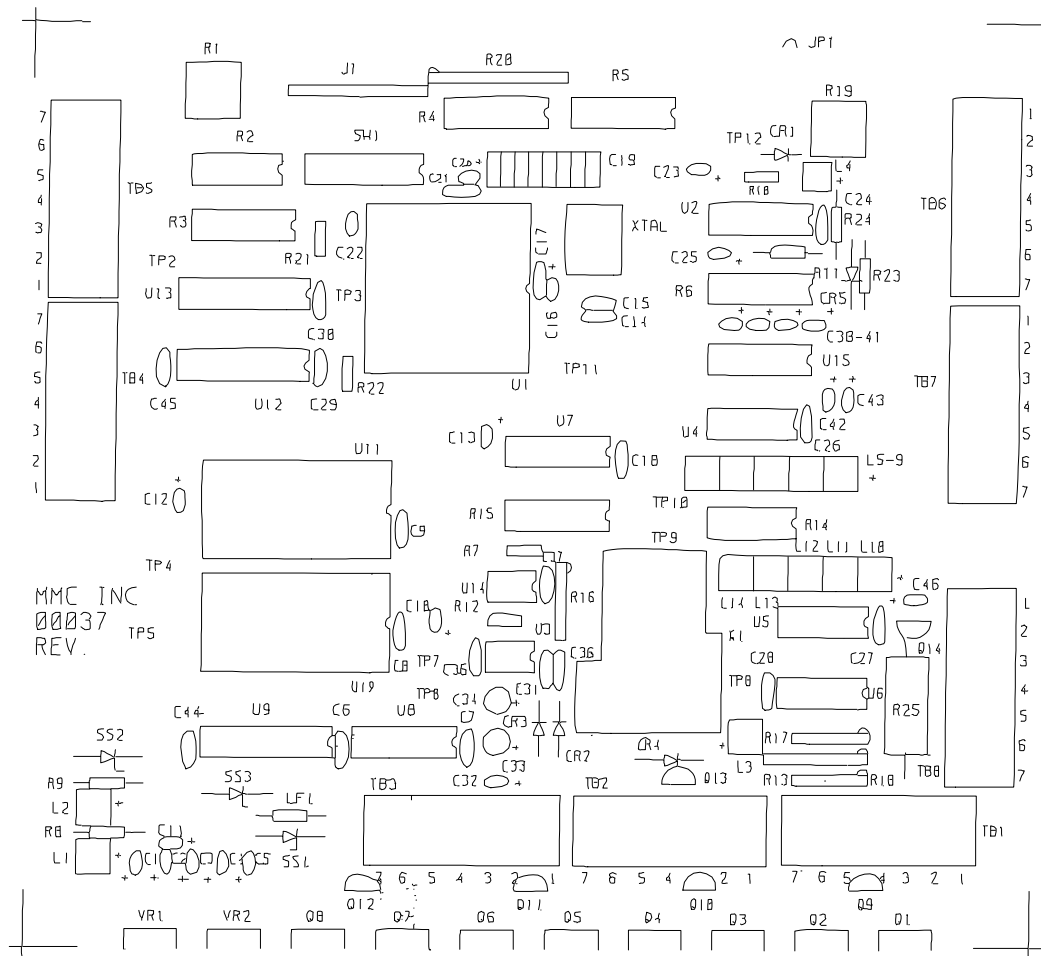

Figure 1: 314 Circuit



580 Trouble Shooting (Most Common Failures)

FAILURE	CAUSE	SYMPTOM(s)
Open Fuse	Applied voltage exceeded 20 VDC Debris on the circuit board Component failure A Rev. C circuit (S/N 5600-5900) that hasn't been upgraded.	Cannot take control No lights illuminated No Tones
Bad Motor	Push-pull cable travel improperly adjusted.	Either the shift or throttle servo won't extend and retract (high repetition tone) Trips circuit breaker
Bad Feedback Assembly	Loose fitting plug Rev. C only (05600 - 05900) Open spot in Feedback Potentiometer	One short/one long "shift error" - Two short/one long "throttle error" - clutch stays in gear, throttle to Idle. Depressing transfer button, clears the tone
Micro-controller Socket Bad	Socket and Controller not making good contact (Cannon Sockets only)	Erratic Behavior Solid Tone

TECHNICAL TIPS

- The 580 Actuator requires 12 VDC - 16 VDC for proper operation.
- Check the voltage at the battery, and then at the Actuator. The difference should not exceed 250MV.
- Improper bonding on metal hulls can subject the 580 to electrical noise interference which can produce erratic behavior.
- The circuit board may be replaced with the 580 Actuator. Before replacing the circuit board, do the Motors and Feedback Potentiometers Test (SER-126), and the Control Head Test (SER-125) to ensure it is the circuit board which is defective.
- So we can better support you, have the serial number available. The serial number is printed just above the brown, twenty-five pin plug.
- The 580 Actuator is compatible with Synchronization. A software change may be required. This can be accomplished in the field.
- The 580 Actuator is compatible with Troll, with the exception of serial numbers 05600 - 05900.

TEST POINTS AND LEDs

TEST POINT	INDICATION	EXPECTED READING
TP1	Ground	0 VDC
TP2	VCC (5 volt supply)	4.8 VDC - 5.1 VDC
TP3	Reset	4.8 VDC - 5.1 VDC
TP4	Clock	MHz 5 V P-P

LIGHT	INDICATION	
L1	Watch-Dog	
L2	Voltage Doubler	
L3	Motor Power Availability	
L4	Shift Retract	
L5	Shift Extend	
L6	Throttle Retract	
L7	Throttle Extend	

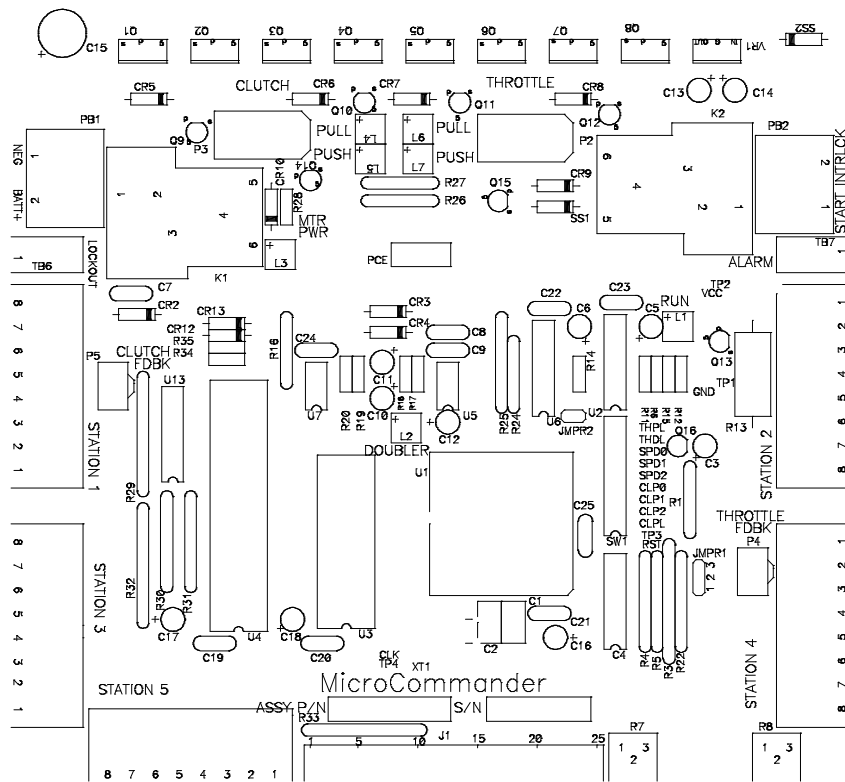

Figure 1: 580 Circuit



585 Trouble Shooting (Most Common Failures)

FAILURE	CAUSE	SYMPTOM(s)
1) Open Fuse	a) Debris on the circuit board b) Applied voltage exceeded 40 VDC c) Component failure	a) Cannot take control b) No light's illuminated c) No Tones
2) Burnt Ground Traces	a) A difference in potential between PB1 and stations 1 thru 5, Terminal 8	a) Cannot start engine Solid Tone
3) Shift Feed-back Error	a) Defective shift feed-back potentiometer.	a) Prior to S/N 13966 - Steady tone after shifting. Depressing transfer button twice, restores normal control. b) S/N 13966 to present - One long followed by one short tone. After shift, depressing the transfer button twice restores normal operation.
4) Throttle Feedback Error	a) Defective throttle feedback potentiometer.	a) Prior to S/N 13966 - Steady tone after change in throttle position. Throttle drives to low idle. Depressing transfer button twice restores normal control. b) S/N 13966 to present - One long followed by two short tones. Throttle drives to low idle. Depressing the transfer button twice restores normal operation.
5) The 585 Actuator can be interfaced with Electronic Governors and Electric Gear Shifts. Contact the factory for details.		

TECHNICAL TIPS

1. The 585 Actuator requires 12 VDC - 40 VDC for proper operation.
2. The 585 Actuator produces a noise when powered.
3. The Actuator is compatible with Synchronization and Troll. A software change may be required. This can be accomplished in the field.
4. The circuit board may be replaced in the field. Before replacing the circuit do the Motor and Feedback Potentiometer Test (SER-126), and the Control Head Test (SER-125) to ensure it is the circuit board which is defective.

TEST POINTS AND LED'S

TEST POINT	INDICATION	EXPECTED READING
TP1	Ground	0 VDC
TP2	VCC (5 volt supply)	4.8 VDC - 5.1 VDC
TP3	Reset	4.8 VDC- 5.1 VDC
TP4	Clock	3MHZ 5 V P-P

LED	INDICATION	
L1	Watch-Dog	
L2	Voltage Doubler	
L3	Power Available to the Motors	
L4	Shift Retract	
L5	Shift Extend	
L6	Throttle Retract	
L7	Throttle Extend	

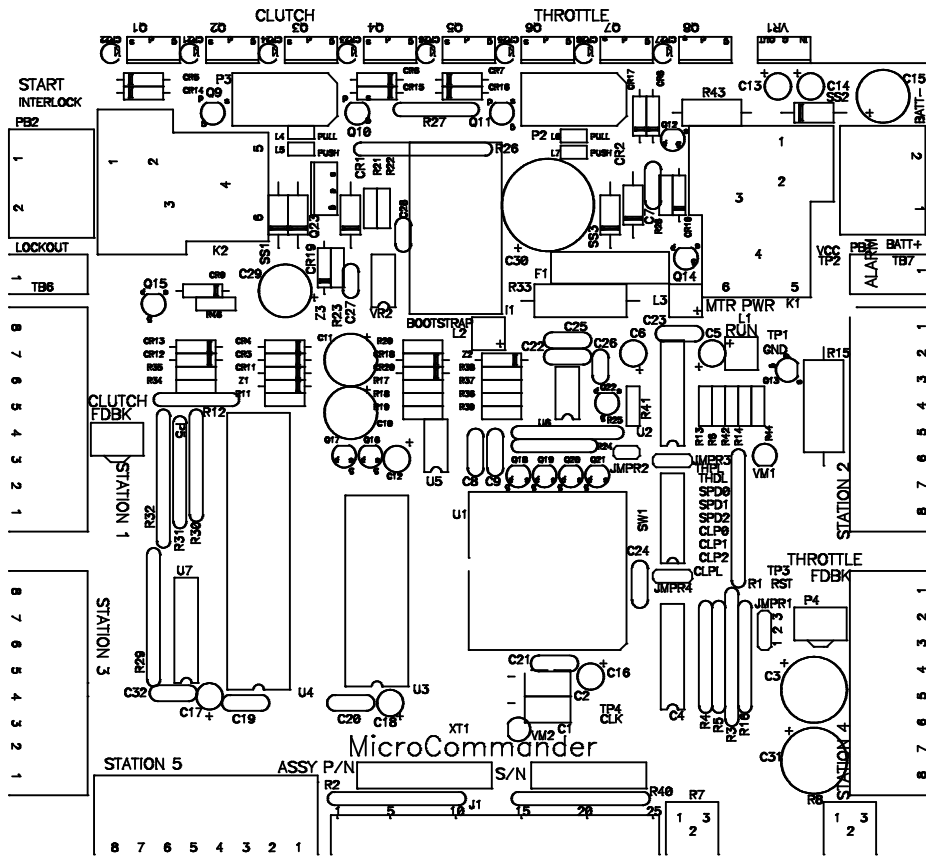

Figure 1: 585 Circuit



SER-124 Rev.- 1/97

ZF Mathers, LLC
1415 Pacific Drive
Burlington WA 98233-3103 U.S.A.
800-546-5455 / 360-757-6265
Fax: 360-757-2500

MicroCommander Trouble Shooting Guide

DATE: _____

- 1) NAME (who are you talking to?)
COMPANY NAME
TELEPHONE NUMBER
VESSEL NAME LOCATION
SITUATION

- 2) APPLICATION:
a) Length Type of Vessel
b) Engine Transmission No. of screws

MicroCommander Model Serial Number Synch Troll
Proximity to engines? ft No. of Control Stations

- 3) Who Installed Mathers Contact

- 4) SYMPTOMS (listen) (take notes)

- 5) WHAT DO YOU THINK THE PROBLEM IS?

- 6) WHEN DOES THE PROBLEM OCCUR?
HOW OFTEN

- 7) IS IT ISOLATED TO ONE STATION?

- 8) WHAT HAS BEEN DONE TO THIS POINT?

- 9) TESTS

- 10) SOLUTIONS

- 11) MRA #

Conductor Sizes for 10% Drop in Voltage

Length of Cable from the source of current to the MicroCommander.

Recommended Gauge for 12 Volt Systems

Length (in feet)	15	20	25	30	40	50	60	70	80	90
	14	14	12	12	10	10	N/R	N/R	N/R	N/R

Recommended Gauge for 24 Volt Systems

14	14	14	14	14	12	12	10	10	10
----	----	----	----	----	----	----	----	----	----

Recommended Gauge for 32 Volt Systems

14	14	14	14	14	14	12	12	12	10
----	----	----	----	----	----	----	----	----	----

N/R represents Not Recommended. When the cable length exceeds the recommended lengths, a relay system as shown in Figure 1: is recommended.

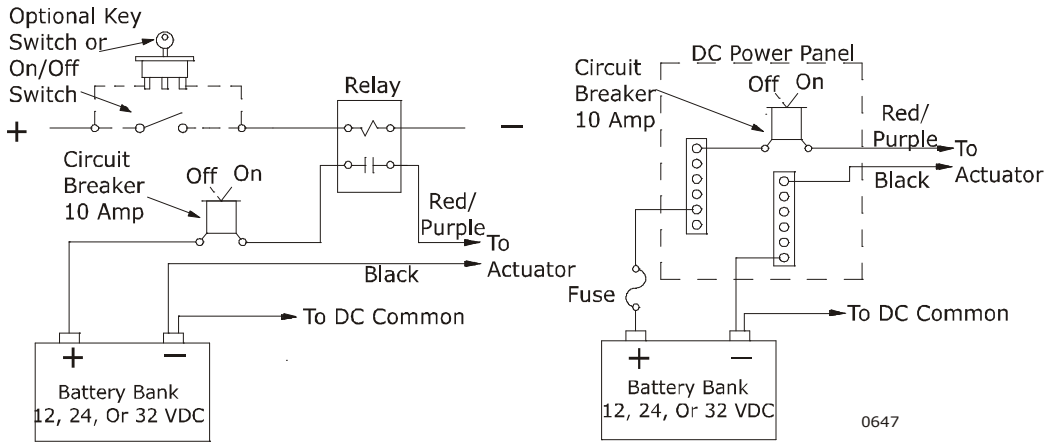

Figure 1: Power Connections

Conductor sizes may be calculated by means of the following formula:

$$CM = \frac{K \times I \times L}{E}$$

CM = Circular mil area of the conductor.

K = 10.75 (A constant representing the mil-foot resistance of copper).

I = Load current in amperes.

E = Voltage drop at load in volts.

L = Length of the conductors to and from the power source.

Example: To calculate the required gauge for 40 feet of cable on a 12 volt system with 10 amp current draw and a 10% voltage drop.

$$CM = \frac{10.75 \times 10 \times 80}{1.2}$$

$$CM = 7,166.66$$

Refer to the conversion chart. 12 AWG (gauge) with 7/20 stranding wire is 7,168 circular MILs. This would be the choice.

Technical Data
AWG / Metric Stranded Conductor Chart

AWG	Strand	Approx. O.D.		Area		Weight		AWG	Strand	Approx. O.D.		Area		Weight			
		Inches	mm	Circular MIL	Square Inches	mm	Lbs/kft			kg/km	Inches	mm	Circular MIL	Square Inches	mm	Lbs/kft	kg/km
36	7/44	.006	.15	28.00	-	.014	.085	.12	14	19/27	.073	1.85	3,830.4	.0030	1.95	11.59	17.24
34	7/42	.007	.19	43.75	-	.022	.132	.19	14	41/30	.073	1.85	4,100.0	.0032	2.09	12.40	18.45
32	7/40	.008	.20	67.27	.0001	.034	.203	.30	14	105/34	.073	1.85	4,167.5	.0033	2.12	12.61	18.76
32	19/44	.009	.22	76.00	.0001	.038	.230	.34	12	7/20	.096	2.43	7,168.0	.0057	3.65	21.69	32.27
30	7/38	.012	.30	112.00	.0001	.057	.339	.50	12	19/25	.093	2.36	6,087.6	.0048	3.10	18.43	27.42
30	19/42	.012	.30	118.75	.0001	.060	.359	.53	12	65/30	.095	2.41	6,500.0	.0051	3.31	19.66	29.25
28	7/36	.015	.38	141.75	.0001	.072	.529	.78	12	165/34	.095	2.41	6,548.9	.0052	3.33	19.82	29.49
28	19/40	.016	.40	182.59	.0001	.093	.553	.82	10	37/26	.115	2.92	9,353.6	.0074	4.77	28.31	42.12
27	7/35	.018	.45	219.52	.0002	.112	.664	.98	10	49/27	.116	2.94	9,878.4	.0078	5.03	29.89	44.47
26	10/36	.021	.53	250.00	.002	.127	.757	1.12	10	105/30	.116	2.94	10,530.0	.0083	5.37	31.76	47.26
26	19/38	.020	.50	304.00	.0002	.155	.920	1.36	8	49/25	.147	3.73	15,699.9	.0124	8.00	47.53	70.72
26	7/34	.019	.48	277.83	.0002	.141	.841	1.25	8	133/29	.147	3.73	16,984.1	.0134	8.66	51.42	76.51
24	7/32	.024	.60	448.00	.0004	.228	1.356	2.01	8	655/36	.147	3.73	16,625.0	.0131	8.47	49.58	73.78
24	10/34	.023	.58	396.90	.0003	.202	1.201	1.78	6	133/27	.184	4.67	26,812.8	.0212	13.67	81.14	120.74
24	19/36	.024	.60	475.00	.0004	.242	1.430	2.12	6	259/30	.184	4.67	25,900.0	.0205	13.20	78.35	116.59
24	41/40	.023	.58	384.40	.0003	.196	1.160	1.72	6	1050/36	.184	4.67	26,250.0	.0208	13.38	79.47	118.25
22	7/30	.030	.76	700.00	.0006	.357	2.120	3.15	4	133/25	.232	5.89	42,613.0	.0337	21.73	129.01	191.98
22	19/34	.031	.78	754.11	.0006	.384	2.280	3.39	4	259/27	.232	5.89	52,214.4	.0413	26.62	158.02	235.15
22	26/36	.030	.76	650.00	.0005	.331	1.970	2.93	4	1666/36	.232	5.89	41,650.0	.0329	21.24	126.10	187.64
20	7/28	.038	.96	1111.00	.0009	.562	3.490	5.19	2	133/23	.292	7.41	67,936.4	.0537	34.64	205.62	305.98
20	10/30	.035	.88	1000.00	.0008	.510	3.025	4.50	2	259/26	.292	7.41	65,475.2	.0518	33.39	198.14	294.85
20	19/32	.037	.93	1216.00	.0010	.620	3.680	5.47	2	665/30	.292	7.41	66,500.0	.0526	33.91	201.16	299.34
20	26/34	.036	.91	1031.94	.0008	.526	3.120	4.64	2	2646/36	.292	7.41	66,150.0	.0523	33.73	200.28	298.03
20	41/36	.036	.91	1025.00	.0008	.522	3.100	4.61	1	163,195.9	.328	8.33	85,133.3	.0673	43.41	257.60	383.33
18	7/26	.048	1.21	1769.60	.0014	.902	5.360	7.97	1	172,508.0	.328	8.33	82,983.6	.0656	42.32	251.20	373.81
18	16/30	.047	1.19	1600.00	.0013	.816	4.840	7.20	1	817/30	.328	8.33	81,700.0	.0646	41.66	247.10	367.71
18	19/30	.049	1.24	1900.00	.0015	.969	5.750	8.55	1	2019/34	.328	8.33	83,706.2	.0662	42.69	253.29	376.92
18	41/34	.047	1.19	1627.29	.0013	.829	4.920	7.32	1/0	133/21	.368	9.34	108,035.9	.0854	55.09	327.05	486.68
18	65/36	.047	1.19	1625.00	.0013	.828	4.910	7.30	1/0	259/24	.368	9.34	104,636.0	.0827	53.36	316.76	471.37
16	7/24	.060	1.52	2828.00	.0022	1.442	8.560	12.73	2/0	133/20	.414	10.51	136,192.0	.1077	69.45	412.17	613.35
16	65/34	.059	1.49	2579.85	.0020	1.315	7.810	11.62	2/0	259/23	.414	10.51	132,297.2	.1046	67.47	400.41	595.85
16	26/30	.059	1.49	2600.00	.0021	1.326	7.870	11.71	3/0	259/22	.464	11.78	163,195.0	.1290	83.22	501.70	746.58
16	19/29	.058	1.47	2426.30	.0019	1.237	7.350	10.93	3/0	427/24	.464	11.78	172,508.0	1364	87.97	522.20	777.08
16	105/36	.059	1.49	2625.00	.0021	1.338	7.950	11.83	4/0	259/21	.522	13.25	210,385.7	.1663	107.29	638.88	950.71
14	7/22	.073	1.85	4480.00	.0035	2.284	13.560	20.17	4/0	427/23	.522	13.25	218,111.6	.1724	111.23	660.01	982.16



SER-104 Rev.A- 7/01

ZF Mathers, LLC
 1415 Pacific Drive
 Burlington WA 98233-3103 U.S.A.
 800-546-5455 / 360-757-6265
 Fax: 360-757-2500

585 and 585CE Software Versions

SERIAL NO.	PART NO.	VERSION NO.	SOFTWARE CAPABILITIES
10000 - 10074	01044	SBC.98D	1) No Synchronization or Troll
10075 - 10399	01099		
	01100	SBC.98E	1) Added synchronization capability. The 01099 functions as the Lead and the 01100 as the Follow.
10400 - 11459	01167	SBC.98F	1) Changed the clutch engagement crash reversal delay from 2 sec. - 11.25 sec. to 0 sec. - 11.5 sec. 2) Adds troll capability. 3) Combines Lead and Follow functions to one prom. 4) Allows clutch oil pressure switch to be used with troll function.
11460 - 13965	01211	SBC.98G	1) Added PWM output (8% - 92%) using HSO4. Used by the auxiliary board to generate 4-20 mA. signal. 2) Added code to determine if HSI's are working. Light (green) remains illuminated but synchronization does not operate. 3) Added code to deactivate synch. if a change greater than 10% occurs in either HSI signal. 4) Added code to keep the troll cross-bar from driving toward maximum oil pressure when transitioning from HI to LO idle. 5) Added code to declare and limit throttle to 10% if the troll cross-bar does not reach maximum oil pressure within approximately five seconds after lever exceeds troll range. 6) Automatically count every eighth pulse when sender frequency is greater than 2.5 KHz.
13966 - 14043	01438	SBC.98H	1) Fault specific tones for feedback errors. One long followed by one short indicates clutch error. One long followed by two short indicates throttle error. 2) Modified HSO to reach 98% - 99% duty cycle. Compensates for propagation delays. 3) Once synchronization is obtained (within 3%) and then disabled (transient or other) synchronization is zeroed, only if Follow lever is moved. Otherwise synchronization command remains as is. 4) Altered data bases so that throttle cross-bar reacts to lever movement further out of detent than previously. 5) Operates with 340 degree pots.
14044 - 14756	01441	SBC.98J	1) Changes made to reduce maximum throttle movement from 3 in.- 3.1 in. to 2.88 in. - 2.94 in. This was due to the changes made to the data bases in SBC.98H. 2) Operates with 340 degree pots.
14757 - 14871	01437	SBC.98H	1) This version incorporates serial communication for up to nine station operation. 2) Must be in neutral for one second before start interlock relay is energized.

SERIAL NO.	PART NO.	VERSION NO.	SOFTWARE CAPABILITIES
14872 - 24999	01495	SBC.98K	<ol style="list-style-type: none"> 1) This version incorporates serial communication for up to nine station operation. 2) Must be in neutral for one second before start interlock relay is energized.
25000 - 32961	01654	9.8L	<ol style="list-style-type: none"> 1) This is the first version of software for the 585CE Actuator. The operation is the same as Version number SBC.98K used in the 585 Actuator.
B01001 - B01200	12705	SW12705.0	<ol style="list-style-type: none"> 1. Clutch Oil Pressure Interlock now uses a N.O. switch. Previously N.C. 2. In addition to selecting throttle pause after clutch engagement, SW1-7 on the Main Circuit Board selects a 5 second pause before Clutch Oil Pressure Interlock becomes active. 3. Primary Station Isolation is no longer available. TB6-1 is now utilized by the Gear Oil Pressure Interlock. 4. System powers up in Low Idle Mode. Previously High Idle Mode. 5. The system is in Low Idle Mode when Neutral Fast Idle (Warm-up Mode) is selected. Previously in High Idle Mode. 6. NEW FEATURE - One Long, Three Short Tones indicates out of range fault of the Station-in-Command. 7. NEW FEATURE - Synchronization Mode can be toggled ON/OFF with the Control Head's Transfer Button, while the levers are within the Synch Range. 8. The Control Head lever range dedicated to Troll is 20 degrees. Previously 15 or 25 degrees was selectable. 9. NEW FEATURE - SW1-3 on the Auxiliary Circuit Board sets the Station-in-Command LED to flash while in the Troll Range. 10. NEW FEATURE - SW1-1- 9 on the Auxiliary Circuit Board allows use of the Control Head's Transfer Button to toggle Troll Mode ON/OFF.
B01201 - B01250	12932	SW12705.1	<ol style="list-style-type: none"> 1. Corrects the anomaly where the throttle servo drives slowly when no Auxiliary Circuit Board is installed.
B01251 - B03306	12962	SW12705.2	<ol style="list-style-type: none"> 1. Corrects the anomaly which allows the clutch servo to drive toward Astern when the Station-in-Command's signal is lost.
B03307 - B05499	13430	SW12705.3	<ol style="list-style-type: none"> 1. Corrects the problem which occurs when cycling the Control Head from Ahead to Astern repeatedly.
B05500- B07884	13668	SW12705.4	<ol style="list-style-type: none"> 1. The Processor's servos jam at loads of 10 pounds or more when low battery voltage is applied. The system is now capable of driving up to 40 pounds at 10.45 VDC. 2. The system is now in High Idle when Neutral Fast Idle (Warm-up Mode) is selected. 3. The throttle will now remain at Idle if command is taken initially when the Control Head lever in a position other than Neutral/Idle. The Control Head LED will still blink slowly. 4. If a jam occurs below the High Idle setting, this will be set as the new Low Idle position. This differs from previous versions in that High Idle is still available.
B07885 - Present	13943	SW12705.5	<ol style="list-style-type: none"> 1. An unwanted delay existed after High Idle. This has been removed.

SERIAL NO. PART NO. VERSION NO.**SOFTWARE CAPABILITIES**

2. The point at which synchronization begins has been lowered from 10% to 5%.
 3. The LED's will now flash when Neutral is commanded and Troll is selected.
 4. In addition to the 20 degrees dedicated to Troll, 35 degrees is also selectable using SW1-2 on the Auxiliary Circuit Board.
 5. SW1-4 on the Auxiliary Circuit Board allows the operator the option of powering up with Troll Enabled/Disabled.
 6. In previous versions, the reversal delay time would build-up while in the Troll Range. This has been corrected.
-



MMC-309 Rev.D 10/01

ZF Mathers, LLC
1415 Pacific Drive
Burlington WA 98233-3103 U.S.A.
800-546-5455 / 360-757-6265
Fax: 360-757-2500

MicroCommander Software Upgrade SW12705

Actuators with serial numbers **B01001** through **B05499** are supplied with Software Versions **SW12705.0, .1, .2, & .3.**

Actuators beginning with serial number **B05500** through **ZB08812** were supplied with Software Version **SW12705.4.**

Actuators beginning with serial number **ZB08813** are supplied with Software Version **SW12705.5.**

The following is a summary of the features and changes available with this software upgrade. Before operating your upgraded or new MicroCommander Control System, please review all of the following additions or changes.

CAUTION: On MicroCommander Systems utilizing more than one 585 or 585CE Actuator, ZF Mathers highly recommends that software in ALL UNITS be upgraded to the same revision level at the same time.
DO NOT attempt to operate a 585 or 585CE Actuator with this software upgrade in conjunction with a 585 or 585CE Actuator using any other software version if planning to use the High/Low Idle, Synchronization, Clutch Oil Pressure Interlock, or Trolling options.

Main Features Added or Changed:

- Clutch Oil Pressure Interlock normally open contact added. Switch must close with oil pressure to allow throttle above Idle.

NOTE: If Clutch Oil Pressure switch is not used, a jumper must be connected between TB6-1 and Ground.

- With Main Board Dip Switch 7 ON, clutch pressure is required before throttle can move past idle. With Switch 7 OFF, throttle will be allowed for 5 seconds before Clutch Oil Pressure Interlock becomes active.
- Primary Station Isolation Switch is *no longer available*. [Connection point LOCKOUT is now TB6-1 and is utilized for Clutch Oil Pressure Interlock.]
- Actuator will power up in Low Idle Mode. High Idle may be selected with the transfer button.
 - (SW12705.0, .1, .2, and .3) High Idle adjustments are made with the Control Head lever in the Neutral position.
 - (SW12705.4) High Idle adjustments are made in the Neutral Fast Idle Mode.
- Additional alarm tone: **One Long, Three Short Tones** signals an out of range command signal from the station that was in command at the time the tone started.
- Synchronization Mode can be enabled or disabled by depressing the transfer button on the Control Head in command for one second while in the synchronization range.
 - (SW12705.5) The point at which synchronization begins, has been lowered from 10% to 5% of the throttle range.
- Troll Range is now a standard 20 degrees of Control Head lever movement past the Ahead or Astern detent.
 - (SW12705.5) In addition to the 20 degrees of lever movement dedicated to Troll, 35 degrees may be selected with SW1-2 on the Auxiliary Circuit Board.
- The red LED on the Control Head may be set to flash while in Troll Mode by turning Auxiliary Board Dip Switch 3 to ON.
 - (SW12705.5) The Control Head's red LED will now blink rapidly when Neutral is commanded and Troll is selected.

- Turning Dip Switch 1 on the Auxiliary Circuit Board to ON will enable Troll Toggle. With Control Head lever in the Ahead or Astern Detent, troll may be toggled On or Off by depressing the transfer button on the Control Head in command. Troll Mode Switch must be set to Troll or a Jumper must be in place to use Troll Toggle.

(SW12705.5) SW1-4 on the Auxiliary Circuit Board allows the operator the option of powering up with Troll Enabled or Disabled.

Please refer to the MM12793 585CE Manual for a more complete description of the features available, and for installation and setup instructions.

Software Change Quick Reference Table			
Original Software (01654)	(SW12705.0- 3)	(SW12705.4	Newest Software (SW12705.5)
Clutch Oil Pressure Interlock is normally closed (must open with pressure)	Clutch Oil Pressure Interlock is normally open (must close with pressure)	Clutch Oil Pressure Interlock is normally open (must close with pressure)	Clutch Oil Pressure Interlock is normally open (must close with pressure)
DIP Switch (SW1-7) selects Throttle Pause after clutch engagement	DIP Switch (SW1-7) <u>also</u> selects a 5 second pause prior to Oil Pressure Interlock becoming active.	DIP Switch (SW1-7) <u>also</u> selects a 5 second pause prior to Oil Pressure Interlock becoming active.	DIP Switch (SW1-7) <u>also</u> selects a 5 second pause prior to Oil Pressure Interlock becoming active.
TB6-1 (Station Lockout) used for Primary Station Isolation	TB6-1 (Formerly Station Lock-out) used for Clutch Oil Pressure Interlock	TB6-1 (Formerly Station Lock-out) used for Clutch Oil Pressure Interlock	TB6-1 (Formerly Station Lock-out) used for Clutch Oil Pressure Interlock
System powers up in High Idle Mode	System powers up in Low Idle Mode	System powers up in Low Idle Mode	System powers up in Low Idle Mode
System is in High Idle Mode when Neutral Fast Idle is selected	System is in Low Idle Mode when Neutral Fast Idle is selected	System is in Low Idle Mode when Neutral Fast Idle is selected	System is in Low Idle Mode when Neutral Fast Idle is selected
Feature not available	One Long, Three Short tones indicates an out of range fault of Station-in-Command	One Long, Three Short tones indicates an out of range fault of Station-in-Command	One Long, Three Short tones indicates an out of range fault of Station-in-Command
Feature not available	Synchronization Mode can be toggled On/Off with the Control Head Transfer Button while lever is in synch range	Synchronization Mode can be toggled On/Off with the Control Head Transfer Button while lever is in synch range	Synchronization Mode can be toggled On/Off with the Control Head Transfer Button while lever is in synch range
The Auxiliary Board DIP Switch (SW1-2) selects 15 or 25 degrees of Control Head lever movement dedicated to Troll Range	Troll Range is set to a standard 20 degrees of Control Head lever movement	Synchronization Mode can be toggled On/Off with the Control Head Transfer Button while lever is in synch range	The Auxiliary Board DIP Switch (SW1-2) selects 20 or 35 degrees of Control Head lever movement dedicated to Troll Range
Feature not available	The Auxiliary Circuit Board DIP Switch (SW1-3) sets the Station-in-Command LED to flash rapidly when in the Troll Range	The Auxiliary Circuit Board DIP Switch (SW1-3) sets the Station-in-Command LED to flash rapidly when in the Troll Range	The Auxiliary Circuit Board DIP Switch (SW1-3) sets the Station-in-Command LED to flash rapidly when in Neutral and the Troll Range
Feature not available	The Auxiliary Circuit Board DIP Switch (SW1-1) allows use of Control Head Transfer Button to toggle Troll Mode On/ Off	The Auxiliary Circuit Board DIP Switch (SW1-1) allows use of Control Head Transfer Button to toggle Troll Mode On/ Off	The Auxiliary Circuit Board DIP Switch (SW1-1) allows use of Control Head Transfer Button to toggle Troll Mode On/ Off
The system powers up with Troll Mode Disabled	The system powers up with Troll Mode Disabled	The system powers up with Troll Mode Disabled	The Auxiliary Circuit Board DIP Switch (SW1-4) allows the operator the option of powering up with Troll Enabled or Disabled.



SER-143 Rev.- 3/97

ZF Mathers, LLC
1415 Pacific Drive
Burlington WA 98233-3103 U.S.A.
800-546-5455 / 360-757-6265
Fax: 360-757-2500

813 Troll Actuator Trouble Shooting

INTRODUCTION

Most faults with the Troll Actuator will give the same audible "tone over tone" alarm at the Control Heads. The throttle on the associated 580, 585, or 585CE Actuator (Primary Actuator) is limited to 10 percent of full throttle, but command of shifting remains intact. The most common problems are as follows:

1. There is no power applied to the Troll Actuator. The Troll Actuator must always have power applied, when the Primary Actuator is powered. The Troll Actuator can be enabled (TROLL), or disabled (NON-TROLL), using an optional switch connected to TB5-3 (Terminal Block 5, Terminal 3) and Terminal 4 of the Troll Actuator.
2. A loose or miswired cable between the Troll Actuator and the Primary Actuator's Auxiliary Circuit.
3. The Troll Actuator's push-pull cable(s) are misadjusted, resulting in a jamming condition.
4. Voltage below 10 VDC (Volts Direct Current) to the Troll Actuator may cause the troll alarm.
5. A component failure. The Motor and Feedback Potentiometer Test (SER-126) should be performed if component failure is suspected.

EXPECTED VOLTAGE READINGS

1. Prior to making these voltage readings, ensure that LED's (Light Emitting Diode's) designated on the Troll Circuit Board as L1, L2, and L3, are lit.
2. If LED L1 is blinking, make sure that a connection is made between TB5-3 and -4 of the Troll Circuit Board.

Troll Command Signal

The Troll Command Signal is an analog voltage, which is formed on the Primary Actuator's Auxiliary Circuit. The Primary Actuator commands the formation of this Troll Command Signal. The Troll Actuator supplies the voltage and the return for the formation of the Troll Command Signal. The Troll Command Signal instructs the Troll Actuator's servos where and when to drive.

NOTE: The following measurements should be made at TB1 for Port side trolling valve or TB2 for Starboard. All measurements are on the Troll Actuator's Circuit Board, unless otherwise noted.

1. Measure the voltage between Terminals 1 and 3. The reading should be 4.70 - 4.90 VDC. This voltage is designated as V_{REF} (Voltage Reference).
2. If V_{REF} is not present, disconnect the red wire from Terminal 3. Again, measure the voltage at Terminals 1 and 3. If the voltage is now present, the problem is with the cable or the Primary Actuator's Auxiliary Circuit.
3. If V_{REF} is not present at Terminals 1 and 3, the problem is with the Troll Actuator.
4. Ensure that SW1-6 (Switch 1, position 6) on the Primary Actuator's Auxiliary Circuit is turned On. If the optional TROLL/NON-TROLL switch is utilized, it is turned to TROLL.

5. Ensure that the Control Head lever is at the Neutral Idle position (vertical position). Measure the Command Voltage between Terminals 1 and 2. The measurement should be 23 percent +/- 2 percent of V_{REF} .
6. If the Command Voltage is less than 4.50 VDC, disconnect the brown wire from Terminal 2. Measure the Command Voltage between Terminal 1 and the disconnected brown wire. If the Command Voltage is greater than 4.50 VDC, the problem is on the Troll Circuit Board.
7. If the Command Voltage, as measured across the brown wire and Terminal 1, is still less than 4.50 VDC, the problem is with the eight-conductor cable or the Primary Actuator's Auxiliary Circuit.
8. If the Command Voltage is not present and TROLL was selected, no alarms will be generated. The system will command speed only after the selected 15 or 25 degrees of lever movement is surpassed.
9. Move the Control Head lever to the ahead detent. Measure the Command Voltage at Terminals 1 and 2. The Command Voltage measured should be 73 percent +/- 2 percent of V_{REF} .
10. Slowly move the Control Head lever further ahead. The Command Voltage should slowly decrease to the Command Voltage measured in step 5, and then drop immediately to 0.00 VDC.

Troll Codes

The Primary Actuator monitors the status of the Troll Actuator by utilizing two code lines. These code lines ensure that the Primary Actuator's throttle will not increase above 10 percent of full throttle until the Troll Actuator's servo has reached the full pressure position.

1. Position the Control Head lever to the Neutral Idle position.
2. Measure the Troll Code voltage between Terminal 4 and TP1 (Test Point 1) on the Troll Actuator's circuit board. The Troll Code's voltage measurement should be less than 1.5 VDC.
3. If the Troll Code is greater than 1.5 VDC, disconnect the orange wire from Terminal 4 and measure the voltage between the orange wire and TP1. If the Troll Code is now greater than 10.00 VDC, the problem is on the Troll Actuator's circuit board.
4. If the Troll Code voltage measured in the second sentence of step 3, is less than 10.00 VDC, the problem is with the eight-conductor cable, or the Primary Actuator's Auxiliary Circuit.
5. Measure the voltage between Terminal 5 and TP1 on the Troll Actuator's Circuit Board. The voltage measurement should be greater than 10.00 VDC.
6. If Troll Code voltage measured in step 5 is not greater than 10.00 VDC, disconnect the yellow wire from Terminal 5 and measure the voltage between the red wire and TP1 on the Troll Actuator's Circuit Board. If the voltage is less than 10.00 VDC, the problem is with the eight-conductor cable, or the Primary Actuator's Auxiliary Circuit.
7. If the voltage measured at the red wire is greater than 10.00 VDC, the problem is with the Troll Actuator's Circuit Board.
8. Move the Control Head lever to the ahead detent.
9. Measure the voltage between Terminal 4 and TP1 of the Troll Actuator. The measurement should be greater than 10.00 VDC.

10. If the voltage measure in step 9 is not greater than 10.00 VDC, disconnect the orange wire from Terminal 4. Measure the voltage between the orange wire and TP1. If the voltage is still less than 10 VDC, the problem is with the eight-conductor cable, or the Primary Actuator's Auxiliary Circuit.
11. Measure the voltage between Terminal 5 and TP1. The measurement should be less than 1.5 VDC.
12. If the voltage measured in step 11 is greater than 1.5 VDC, disconnect the yellow wire from Terminal 4. Measure the voltage between the orange wire and TP1. If the voltage is greater than 10.00 VDC, the problem is on the Troll Actuators Circuit Board.
13. If both Terminals 4 and 5 are 10.00 VDC or less than 1.5 VDC at the same time, the Troll Actuator is either faulty, not powered, or not enabled.

813 Technical Tips

If the 813 Actuator were to fail, it can be bypassed using the following steps:

1. Disconnect the push-pull cable from the Trolling Valve lever.
2. Position the trolling lever in the full pressure position.
3. Secure the lever in place using rope or wire.
4. Turn SW1-6 of the (1133 or 1135) Auxiliary Board Off.
5. The Control Heads will now operate as if the trolling valve does not exist.
6. Power may need to be cycled Off, and then On to clear the alarm.
 - The 813 Actuator requires 12, 24 or 32 volt power sources for proper operation.
 - The 813 is not compatible with 314 Systems, or 580 Systems prior to serial number 05900. The 580 Actuators prior to serial number 05900, will work if modified at the factory.
 - Command of the 813 Actuator is limited to the number of remote stations connected to the 580, 585 or 585CE Actuator.

813 Test Points AND LED Indication

TEST POINT	INDICATION	EXPECTED READING (Relative to battery negative)
TP1	Ground	0 VDC
TP2	VCC (5 volt supply)	4.8 - 5.1 VDC
TP3	Reset	4.8 - 5.1 VDC
TP4	Clock	3MHZ 5 V P-P

LED	INDICATION	
L1	Watch-Dog	
L2	Voltage Doubler	
L3	Power Available to the Motors	
L4	Shift Retract	
L5	Shift Extend	
L6	Throttle Retract	
L7	Throttle Extent	

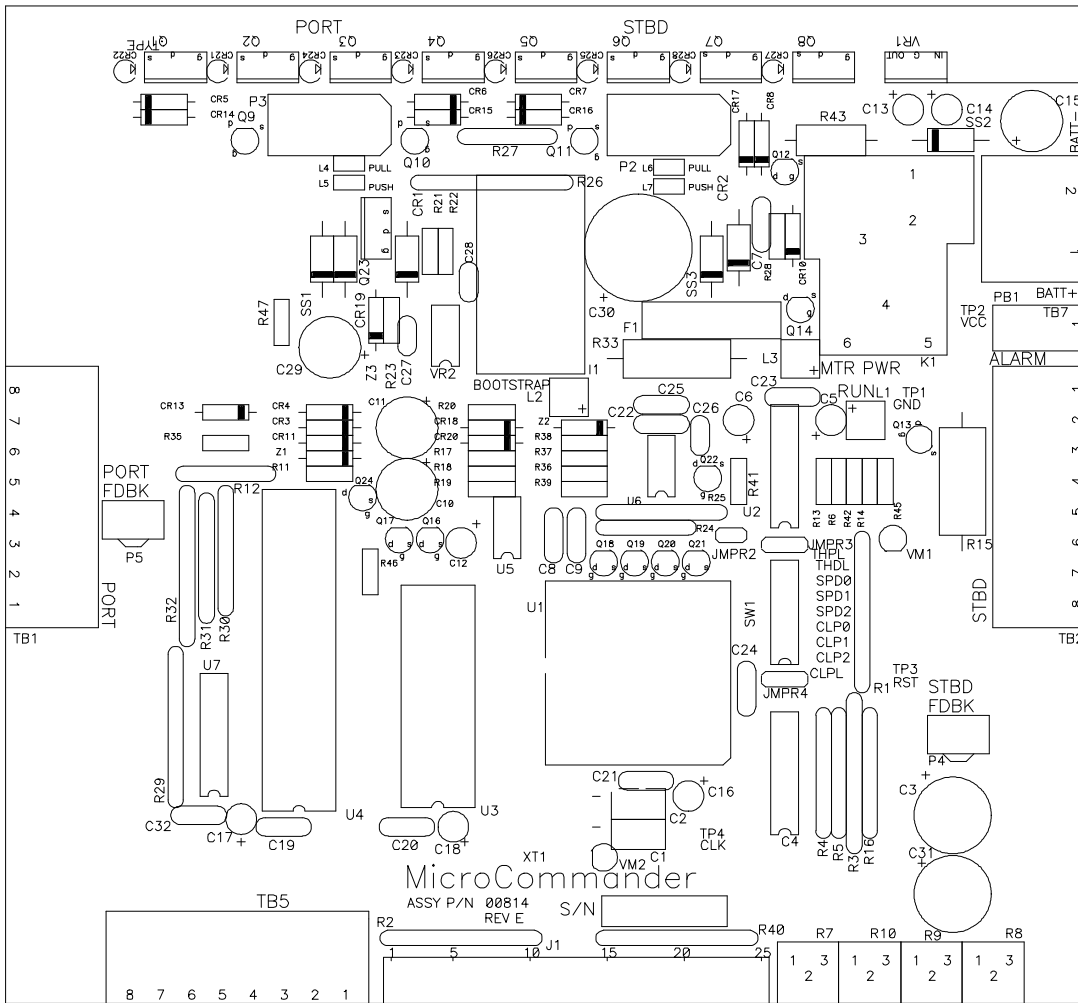

Figure 1: 813 Circuit



813 Trouble Shooting (Most Common Failures)

Any failure of the 813 Actuator will give the same audible "tone over tone" alarm. The throttle on the associated 585 Actuator would be limited to 10 percent of full throttle. The most common reason for these failure indications are as follows:

1. The 813 Actuator has no power applied. The 813 Actuator must always be powered up when the 585 Actuator is powered. The Trolling Actuator can be enabled, or disabled, using an optional switch connected to TB5-3 and 4.
2. Loose, or miswired, eight conductor cable between the 813 Actuator and the 1133, or 1135, Auxiliary Board.
3. Improperly adjusted push-pull cable. A jamming condition.
4. Low voltage to the Actuator.
5. Component failure. The Motor and Feedback Potentiometer Test (SER-126) should be performed if component failure is suspected.

813 **Technical Tips**

1. If the 813 Actuator were to fail, it can be bypassed using the following steps:
 - A) Disconnect the push-pull cable from the trolling valve lever.
 - B) Position the trolling lever in the maximum oil pressure position.
 - C) Secure the lever in place using rope or wire.
 - D) Turn SW1-6 of the 1133, or 1135, Auxiliary Board Off.
 - E) The controls will now operate as if the trolling valve didn't exist.
 - F) Power may need to be cycled Off and then On to clear the alarm.
2. The 813 Actuator require 12 volts - 40 volts for proper operation.
3. The 813 is not compatible with 314 Systems, or 580 Systems prior to serial number 05900.
4. Control of the 813 is limited to the number of stations connected to the 585 Actuator.

813 TEST POINTS AND LEDS

<u>TEST POINT</u>	<u>INDICATION</u>	<u>EXPECTED READING</u>
TP1	Ground	0 VDC
TP2	VCC (5 volt supply)	4.8 - 5.1 VDC
TP3	Reset	4.8 - 5.1 VDC
TP4	Clock	3MHZ 5 V P-P
<u>LED</u>	<u>INDICATION</u>	
L1	Watch-Dog	
L2	Voltage Doubler	
L3	Power Available to the Motors	
L4	Shift Retract	
L5	Shift Extend	
L6	Throttle Retract	
L7	Throttle Extend	

813 CIRCUIT

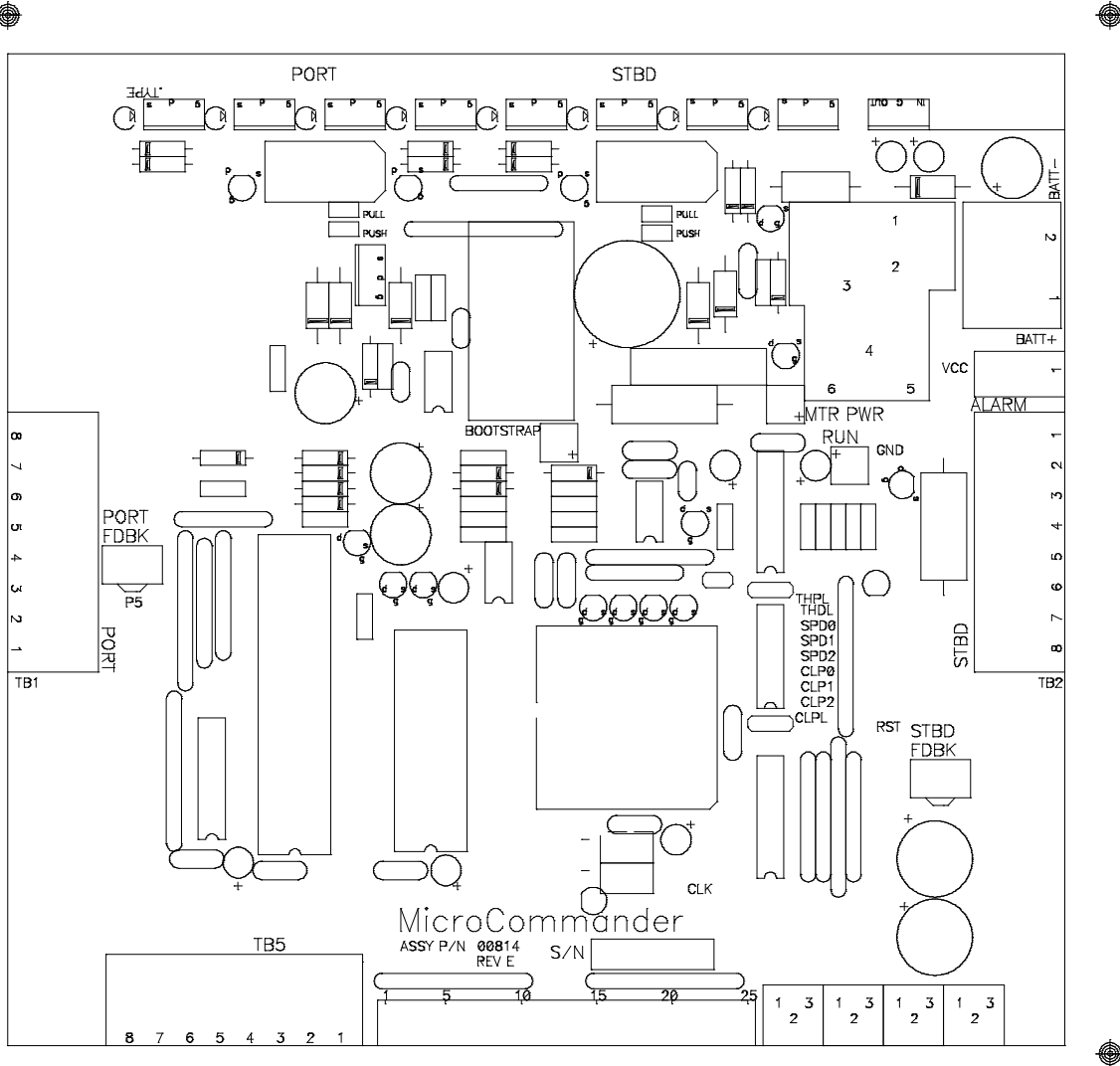



Actuator/Processor Circuit Board Replacement Kits

IMPORTANT: If replacing:

MAIN CIRCUIT BOARD
follow PART 1

AUXILIARY CIRCUIT BOARD follow PART 2

POWER CIRCUIT ASSEMBLY
follow PART 3

REQUIRED TOOLS

- Anti-Static Wrist Strap (Included with Board)
- Screwdriver - small Phillips head #1
- Screwdriver - med. Phillips head #2
- Screwdriver - medium straight slot
- Screwdriver - small straight slot
- 3/16 inch socket driver

PART 1: REPLACING MAIN CIRCUIT BOARD Refer to Figure 1.

REMOVAL

- A) Turn Off power to the Actuator/Processor.
- B) Remove the Actuator/Processor cover.
- CAUTION: Put on anti-static wrist strap provided and connect to frame before working.**
- C) Remove the two Phillips head screws holding the 'Caution' cover plate.
- D) Gently remove "Caution" cover plate.
- E) Disconnect the two potentiometer plugs.
- NOTE: Make careful note of all wiring to Main Circuit Board. The wiring will need to be reconnected after new board is in place.**
- F) Disconnect all wiring connections on the Main Circuit Board.
- G) Remove the five small Phillips head screws holding the circuit board.
- H) Remove the two 3/16 inch hex stand-offs.
- NOTE: Set the dip switches and shunts on the new main circuit board to match the switch and shunts of the old main circuit board.**
- I) Remove by gently pulling up on the main circuit board to unplug it from the power circuit and connector. Record the Serial # _____.
- J) Place the old main circuit board in an anti-static bag and return it to ZF Mathers, LLC.

INSTALLATION

- A) Place the new main circuit board onto Actuator/Processor frame.
- B) Replace the two 3/16 inch hex stand-offs removed in Step H) in REMOVAL.
- C) Replace the five small Phillips head screws removed in Step G) in REMOVAL.
- D) Refer to your Control System Manual and reconnect all wiring to Main Circuit Board as noted in Step F) in REMOVAL.
- E) Reconnect the two potentiometer plugs.
- NOTE: If no E-PROM is included on the new Main Circuit Board, E-PROM must be removed from the original Main Circuit Board and installed on new Main Circuit Board.**
- F) Replace the 'Caution' cover plate using the two Phillips head screws removed in Step D) in REMOVAL.
- G) Refer to Control System Manual for Adjustments and Tests.
- H) Replace Actuator/Processor Cover.

PART 2: REPLACING AUXILIARY CIRCUIT BOARD(S) Refer to Figure 1.

REMOVAL

- A) Turn Off power to the Actuator/Processor.
- B) Remove the Actuator/Processor cover.
- CAUTION: Put on anti-static wrist strap provided and connect to frame before working.**
- NOTE: Make careful note of all wiring to Auxiliary Circuit Board. The wiring will need to be reconnected after new board is in place.**
- C) Disconnect wires from the auxiliary circuit board, noting the current connections.
- D) Remove the three mounting screws.
- NOTE: Set the dip switches and shunts on the new auxiliary circuit board to match the switch and shunts of the old auxiliary circuit board.**
- E) Unplug the auxiliary circuit board from the plug connector of the Actuator/Processor.
- F) Place the old auxiliary circuit board in an anti-static bag and return it to ZF Mathers, LLC.

INSTALLATION

- A) Plug the new auxiliary circuit board into the plug connector of the Actuator/Processor.
- B) Secure the new auxiliary circuit board with the three mounting screws removed in Step D) in REMOVAL.
- C) Reconnect the wires to the new circuit board as noted in Step C) in REMOVAL.
- D) Refer to Control System Manual for Adjustments and Tests.
- E) Replace Actuator/Processor Cover.

PART 3: REPLACING POWER CIRCUIT ASSEMBLY Refer to Figure 1.

REMOVAL

- A) Turn Off power to the Actuator/Processor.
- B) Remove the Actuator/Processor cover.

CAUTION: Put on anti-static wrist strap provided and connect to frame before working.

- C) Remove the Main Circuit Board as described in PART 1: MAIN CIRCUIT BOARD REMOVAL.
- D) Remove the four medium Phillips head screws which are holding the power circuit in place.
- E) Unplug motor plugs from bottom of power circuit assembly.
- F) Remove power circuit assembly without separating the two parts (power circuit and backing plate).

CAUTION: Do not attempt to remove power circuit from backing plate

- G) Place the old Power Circuit Assembly in an anti-static bag and return it to ZF Mathers, LLC.

INSTALLATION

- A) Place new power circuit assembly into Actuator/Processor.
- B) Plug in motor plugs.
- C) Replace the four medium Phillips screws removed in Step D) in REMOVAL.
- D) Reinstall and test the Main Circuit Board as described in PART 1 MAIN CIRCUIT BOARD INSTALLATION.
- E) Refer to Control System Manual for Adjustments and Tests.

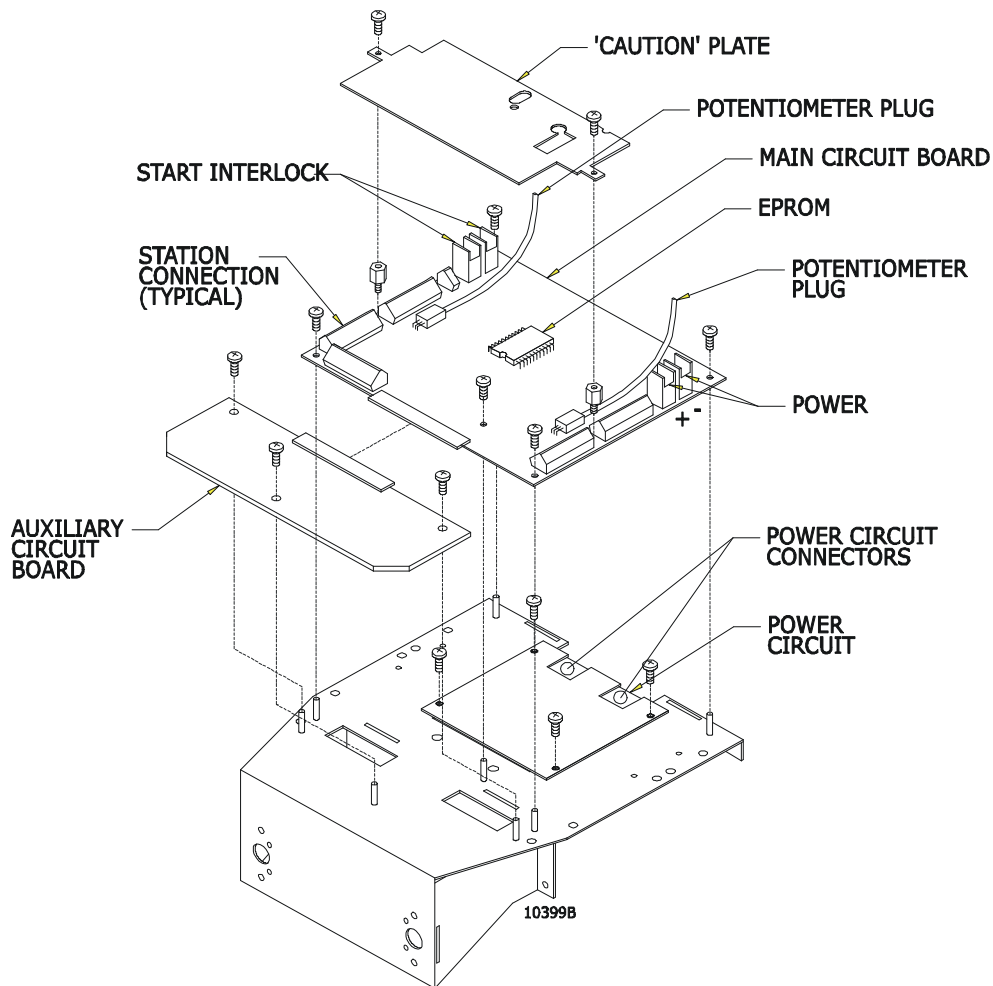

Figure 1:

PROM Change Instructions

PROM

The PROM carries the ZF Mathers Copyright designation.

IMPORTANT: The Actuator/Processor contains electrical components which can be destroyed by static electricity. Personnel should ground themselves to dissipate any static charge while working.

TOOLS REQUIRED:

- Phillips Screwdriver
- Anti-Static wrist strap (provided)
- IC Extractor Tool*

ACCESSING THE PROM

Disconnect Power to the unit. Remove cover from Actuator/Processor. Put on the anti-static wrist strap and connect to the frame before touching the circuit board. Remove two screws that hold the shield in place and remove the shield (see Figure 1).

PROM CHANGE

A) Removal

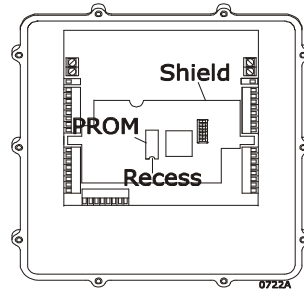

Figure 1:

Before removal, note the location of the recess or notch in the PROM (see Figure 1). Place tabs of *IC Extractor Tool under each end of the PROM. Be careful to hook tool under PROM only, and not under socket (Figure 2). Squeeze the tool to hold the PROM firmly and lift straight up from the socket (use a slight end to end rocking motion if necessary).

B) Installation

Check that the recess or notch on the end of the PROM is in the proper direction (see Figure 2). Tilt the PROM slightly so that one side of 14 prongs will start into the socket. Press lightly against the engaged prongs so that the other set of 14 prongs will start into the socket. Push the PROM straight down firmly. Verify that all the pins are inserted fully in their respective sockets and that none are bent over.

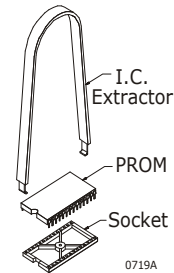

Figure 2:

C) Re-assembly

Place shield over circuit board (See Figure 1) and attach with two screws. The anti-static wrist strap can now be removed. Replace cover.

Affix software part number label (included in kit) just below label on Actuator/Processor cover for ease of future reference.

Please return the removed PROM to ZF Mathers.

*The **IC Extractor Tool** is available from ZF Mathers (P/N EX-1) or from most local electronics stores.

