

CruiseCommand 785CE Installation Manual

MM14330-I Rev.H 6/06



O PREFACE



IMPORTANT: It is important to keep this Manual in a safe place for future reference. The manual contains answers to questions that may arise during operation or installation of the ZF Marine Electronics Control System and its options.

O-1 CruiseCommand 785CE Processors

Table 1: CruiseCommand Processor

ZF Marine Electronics Processor Part No.	ENGINE Elect.	CLUTCH Solenoid	TROLL Solenoid	No. Plug Stations
785CE	YES	YES	YES	4

This manual is intended for use with the above Processors.

O-2 Conventional Symbols Used in the Manual

Throughout this manual special attention should be paid to the following:



NOTE: Contains helpful information



IMPORTANT: Contains helpful information.



CAUTION: Damage to the equipment may occur if these messages are not followed.



WARNING: Personal injury may result if these messages are not followed.

O-3 Important Information



WARNING: Personal Injury could occur if the following steps are not followed exactly.

This manual is written describing all possible options available for this Processor. Your vessel may not require all of these options. Refer to the System Drawing in Appendix C for specifics on what your vessel requires. Refer only to the Sections that apply to your vessel. If you wish to use one of the available options listed, please contact a ZF Marine Electronics Representative for further information.



SW13867.1E

Table of Contents

**CruiseCommand 785CE
Installation Manual**

0	PREFACE - - - - -	0 0-1
0-1	CruiseCommand 785CE Processors	0 0-1
Table 1:	CruiseCommand Processor.....	0 0-1
0-2	Conventional Symbols Used in the Manual	0 0-1
0-3	Important Information	0 0-1
Table of Contents.....		TOC-1
REVISIONS LIST		TOC-11
1	INTRODUCTION - - - - -	1-1
1-1	Manual Contents	1-1
1-2	Basic Theory of Operation.	1-1
1-2.1	785CE Processor (Throttle - Electronic, Shift - Solenoid, Four Pluggable Remote Stations) . . .	1- 1
1-3	System Features	1-2
1-3.1	Standard Processor Features	1- 2
1-3.2	Optional Processor Features	1-2
2	OPERATION - - - - -	2-3
2-1	DC Power On	2-3
2-2	Taking Command	2-3
Figure 1:	Station taking Command	2-3
2-3	Basic Operation	2-4
2-3.1	Normal Operating Mode	2- 4
Figure 2:	Control Head Detents	2-4
2-3.2	Trolling Valve (optional)	2-4
2-3.2.1	Operation in Non-Troll Mode.....	2- 4
2-3.2.2	Operation in Troll Mode.....	2-4
2-3.2.2.1	Turn Troll ON - - - - -	2- 4
2-3.2.2.2	Operation - - - - -	2-5
2-3.2.2.3	Turn Troll OFF - - - - -	2-5
2-4	Start Interlock (if used)	2-5
2-5	Station Transfer	2-5
Figure 3:	Remote Stations Before Transfer of Command	2-6
Figure 4:	Remote Station Transfer after Transfer of Command	2-6
2-6	Warm-up Mode (Throttle Only Mode)	2-6
Figure 5:	Control Head Warm-Up Mode	2-6
Figure 6:	Control Head Normal Operating Mode	2-6
2-7	High/Low Idle	2-7
2-7.1	Low Idle	2- 7
2-7.2	High Idle.	2-7
2-7.3	Selecting Between High and Low Idle	2-7
Figure 7:	High/Low Idle Mode Selection	2-7

TABLE OF CONTENTS

2-8	Engine Synchronization (Multi Screw)	2-7
2-8.1	Synchronization Criteria	2- 8
2-8.2	Synchronization Types	2-8
2-8.2.1	Equal Throttle Electronic Synchronization (default)	2- 8
2-8.2.2	Active Synchronization	2-8
2-8.3	Synchronization Indications	2-8
2-8.4	Turning Synchronization OFF/ON when Criteria is Met	2-8
2-8.4.1	Turning OFF:	2- 8
2-8.4.2	Turning ON:	2-9
2-9	One Lever Mode (Multi Screw)	2-9
2-9.1	Turning ON One Lever Operation	2- 9
Figure 8:	Step A) One Lever Operation Mode	2-9
Figure 9:	Step B) One Lever Operation Mode	2-9
2-9.2	Turning OFF One Lever Operation.	2-10
2-10	Optional Features	2-10
2-10.1	External Alarm Capability	2- 10
2-10.2	Auxiliary Backup Control System.	2-10
2-10.3	Clutch Pressure Interlock	2-10
2-10.4	Multiple Screw Installations	2-11
2-10.5	Station Expander (SE).	2-11
3	PLAN THE INSTALLATION - - - - -	3-12
3-1	System Requirements	3-12
Figure 10:	Processor	3-12
3-1.1	Processor(s)	3- 12
3-1.2	Control Head(s)	3-13
3-1.3	Wire Harnesses	3-13
Table 2:	Processor Harness Connector Locations	3-14
Figure 11:	Harness Plug Connectors	3-14
Figure 12:	Processor Connector and Harness Plug Keying	3-14
3-1.3.1	Control Head Harnesses	3-14
3-1.3.2	Power, Start Interlock, Clutch Pressure (optional), Alarm (optional) Harness	3-14
3-1.3.3	Serial Communication Harness	3-15
3-1.4	Additional Harnesses	3-15
3-1.4.4	Clutch Harness	3-15
3-1.4.5	Clutch/Troll Harness	3-15
3-1.4.6	Throttle Harness	3-15
3-1.4.7	Tach Sensor Harness	3-16
3-2	Tachometer Sensors	3-16
3-2.1	AC Coupled Sensors	3- 16
3-2.2	Alternator	3-16
3-2.3	Point side of the Coil.	3-16
3-2.4	Active Sensors (Open Collector Output)	3-16
3-3	Installer Supplied Tools And Parts	3-17
3-3.1	Required Tools	3- 17
3-3.2	Optional Tools	3-17
3-3.3	Engine Stop Switch	3-17
3-4	DC Power Source	3-17
3-4.1	Processor Power	3- 17
3-4.2	Clutch Power	3-18
4	INSTALLATION - - - - -	4-19
4-1	Processor	4-19
Figure 13:	Processor Dimensions	4-19

TABLE OF CONTENTS

4-2	Control Head(s)	4-19
4-2.1	400, MC2000 and 700 Series Control Heads	4- 19
4-2.2	500 Series Control Heads	4-19
4-2.3	Handheld Remote Controls	4-19
4-3	Wire Harness Installation	4-20
4-3.1	Harness Plug Insertion and Extraction	4- 20
4-3.2	Standard Control Head Harness	4-20
4-3.2.1	Control Head Harness with Two Connectors.....	4- 20
4-3.2.2	Control Head Harness with One Plug.....	4-20
4-3.3	Standard Power/Start Interlock/Alarm(optional)/Clutch Pressure Switch(optional) Harness . .	4-21
4-3.3.1	DC Power Cable	4- 21
4-3.3.2	Start Interlock Cable	4-21
Figure 14:	Start Interlock Connections	4-21
4-3.3.3	External Alarm Circuit (optional)	4-21
4-3.3.4	Clutch Pressure Switch (optional)	4-21
4-3.4	Serial Communication Harness (Multi Screw)	4-22
4-3.4.1	Twin Screw Serial Communication (Required for both Synchronization Types).....	4- 22
4-3.4.2	Tachometer Sensor (Required for Active Synchronization Only)	4-22
4-3.5	Additional Harnesses	4-22
4-3.5.1	Throttle Harness	4- 22
4-3.5.2	Clutch Harness	4-22
4-3.5.3	Clutch/Troll Harness	4-23
4-4	Engine Stop Switches	4-23
5	SET UP PROCEDURE - - - - -	5-24
5-1	Processor Components Used In Set Up.	5-24
Figure 15:	Processor Display LED and Arrow Push Buttons	5-24
5-1.1	Processor Display LED	5- 24
Figure 16:	Display LED at Normal Operation	5-24
Figure 17:	Display LED Designations	5-24
5-1.2	Push Buttons	5-24
Figure 18:	Arrow Push Buttons	5-24
5-1.2.1	"Up" and "Down" Push Buttons	5- 24
5-1.2.2	"Left" and "Right" Push Buttons	5-24
5-1.2.3	"Left" Push Button Only	5-25
Figure 19:	Error Menu Example	5-25
5-1.2.4	"Right" Push Button Only	5-25
Figure 20:	Display LED Four Digit Value	5-25
5-2	Activating Set Up Mode	5-25
5-3	Storing Values To Memory	5-25
5-4	Function Codes And Values	5-26
Table 3:	Processor Function Codes	5-26
Table 4:	Electric Throttle Function Codes	5-27
Table 5:	Clutch Function Codes	5-27
Table 6:	Trolling Valve Function Codes	5-27
Table 7:	Troubleshooting Function Codes	5-28
5-5	Field Service Test Unit (Break-out Box) and Multimeter Use	5-28
Table 8:	Electric Throttle Functions requiring Field Service Test Unit and Multimeter	5-28
Table 9:	Solenoid Trolling Functions requiring Field Service Test Unit and Multimeter	5-29
5-6	System Programming And Adjustments	5-29
5-6.1	Processor Functions	5- 29
5-6.1.1	Function Code A1 – Number of Engines	5- 29
Figure 21:	Display LED Function A1	5-29
5-6.1.2	Function Code A0 – Processor Identification	5-30
Figure 22:	Display LED Function A0	5-30
5-6.1.3	Function Code A2 – One Lever Operation	5-30
Figure 23:	Display LED Function A2	5-30

TABLE OF CONTENTS

5-6.1.4	Function Code A3 – SE (Station Expander).....	5-31
5-6.1.5	Function Code A4 – Neutral Indication Tone.....	5-31
Figure 24:	Display LED Function A4	5-31
5-6.2	Throttle Functions.	5-31
Table 10:	Throttle Functions Performed during Dock Trials.....	5-31
5-6.2.6	Function Code E0 – Electric Engine Throttle Profile.....	5-31
Figure 25:	Display LED Function E0	5-32
5-6.2.7	Function Code E7 – Active Synchronization.....	5-32
Figure 26:	Display LED Function E7	5-32
5-6.3	Clutch Functions.	5-32
Table 11:	Basic Clutch Functions Performed during Sea Trials.....	5-32
5-6.3.1	Function Code C0 – Clutch Pressure Interlock	5- 32
Figure 27:	Display LED Function C0	5-33
5-6.3.2	Function Code C1 – Clutch Interlock Delay.....	5-33
Figure 28:	Display LED Function C1	5-33
5-6.3.3	Function Code C4 – Proportional Pause Ratio.....	5-33
Figure 29:	Display LED Function C4	5-34
5-6.4	Troll Functions	5-34
Table 12:	Troll Function Performed during Dock Trials.....	5-34
Table 13:	Troll Functions Performed during Sea Trials.....	5-34
5-6.4.4	Function Code L0 – Troll Enable and Control Head Lever Troll Range	5-34
Figure 30:	20 Degree Troll Range - Type 1	5-34
Figure 31:	35 Degree Troll Range - Type 2	5-34
Figure 32:	45 Degree Troll Range - Type 3	5-34
Figure 33:	Display LED Function L0	5-35
5-6.4.5	L1 - Solenoid Troll Valve Function.....	5-35
Table 14:	Solenoid Trolling Valve Function L1 Type Selection.....	5-35
Figure 34:	Display LED Function L1	5-35
5-6.5	Troubleshooting Functions	5-35
5-6.5.1	Function Code H0 - Diagnostics	5- 35
5-6.5.2	Function Code H1 – Return to Factory Defaults	5-35
5-6.5.3	Solenoid Troubleshooting Functions.....	5-36
5-6.5.3.1	Function Code H2 - Driver Fault Detection Enable -	5- 36
Table 15:	Solenoid Error Status Enable.....	5-36
6	DOCK TRIALS - - - - -	6-38
6-1	Control Heads (Engines Stopped)	6-38
6-2	Start Interlock (Engines Stopped)	6-38
6-3	Throttle Dock Settings (Engines Stopped)	6-38
6-3.1	E2 - Throttle Minimum and E3 - Throttle Maximum Signal	6- 38
6-3.1.1	Processor Throttle Signal Check	6- 39
Table 16:	Throttle Output Adjustments.....	6-39
6-3.1.2	Throttle Adjustment.....	6-40
Figure 35:	Display LED Function E2	6-40
Figure 36:	Display LED Function E3	6-40
6-4	E4 - Throttle Maximum Astern(Engines Stopped)	6-40
Figure 37:	Display LED Function E4	6-40
6-5	Engine Stop Switches (Engines Running)	6-40
6-6	Control Head Command Checks (Engines Running)	6-41
6-7	E1 - Throttle in Neutral (Cummins-Quantum Engines Only) (Engines Running)	
	6-41
Figure 38:	Display LED Function E1	6-41
6-8	E5 - Throttle Pause Following Shift (Engines Running)	6-42
Figure 39:	Display LED Function E5	6-42
6-9	E6 - High Idle (Engines Running)	6-42
Figure 40:	Display LED Function E6	6-42

TABLE OF CONTENTS

6-10	L7 - Lock Up Percentage (Hurth Transmissions Only) (Engines Running) . . .	6-43
Figure 41:	Display LED Function L7	6-43
7	SEA TRIALS - - - - -	7-44
7-1	Full Speed Setting	7-44
7-2	C2 - Proportional (Reversal) Pause	7-44
7-2.1	In-Gear Delay [C200]	7- 44
7-2.2	Neutral Delay [C201]	7-44
7-2.3	Store C2 - Proportional Pause Value	7-45
Figure 42:	Display LED Function C2	7-45
7-3	C3 - Proportional (Reversal) Pause Time	7-45
7-3.1	Determine C3 Pause Requirement	7- 45
7-3.2	Program Function Code C3.	7-45
Figure 43:	Display LED Function C3	7-45
7-3.3	Testing Proportional (Reversal) Pause Time.	7-45
7-4	Synchronization Test.	7-46
7-4.1	Equal Throttle Synchronization	7- 46
7-4.2	Active Synchronization	7-46
7-5	L2 - Trolling Minimum and L3 - Trolling Maximum Adjustments	7-47
Table 16:	Record Propeller Shaft RPM at Idle Ahead	7-47
7-5.1	L2 - Troll Minimum Set Up	7- 47
Figure 44:	Display LED Function L2	7-47
Table 17:	Record L2 - Minimum Trolling Pressure.	7-48
7-5.1.1	L3 - Troll Maximum Set Up	7-48
Figure 45:	Display LED Function L2	7-48
Table 18:	Record L3-Maximum Trolling Pressure.	7-48
7-6	L4 - Troll Throttle Limit	7-49
Figure 46:	Display LED Function L4	7-49
7-7	L5 - Troll Pulse Duration	7-49
Figure 47:	Display LED Function L5	7-49
7-8	L6 - Troll Pulse Percentage	7-50
Figure 48:	Display LED Function L6	7-50
7-9	Sea Trial Report	7-50
Table 19:	Vessel Information	7-50
7-9.1	Control System Checks	7- 50
Table 20:	Processor	7-50
Table 21:	Harness/Cable Lengths.	7-51
Table 22:	Power Supply	7-51
Table 23:	Dock Trials	7-52
Table 24:	Record at Dock (Requires use of Field Service Test Unit)	7-52
Table 25:	Sea Trials.	7-52
Table 26:	Record during Sea Trials (Requires use of Field Service Test Unit)	7-52
7-9.2	Record Parameters	7-53
Table 27:	Record Processor Functions	7-53
Table 28:	Record Throttle Functions.	7-53
Table 29:	Record Clutch Functions	7-53
Table 30:	Record Troll Functions	7-53
Table 31:	Troubleshooting Functions	7-54
7-9.3	Comments (Please use additional paper as necessary):	7-54
7-9.3.1	General Installation Condition	7- 54
7-9.3.2	Any Irregularities:	7-54
8	CONTROL OPTIONS - - - - -	8-55
8-1	External Alarm Capability	8-55
Figure 49:	Example of Control System Status Indication	8-55
Figure 50:	Example of External Alarm Connection Requirements	8-55

TABLE OF CONTENTS

8-1.1 Installation 8- 55

8-2 Auxiliary (Backup) Control System 8-56

8-3 Clutch Pressure Interlock 8-56

8-3.1 C0 - Clutch Pressure Interlock Methods of Operation 8- 56

8-3.1.1 01 - Installed 8- 56

8-3.1.2 02 - Throttle Clutch Pressure Interlock 8-56

Figure 51: Clutch Pressure Switch with Processor Harness Diagram 8-57

8-3.2 Installation 8-57

8-4 Station Expander (SE) 8-57

9 PERIODIC CHECKS AND MAINTENANCE - - - - - 9-58

9-1 Control Heads. 9-58

9-2 Processor 9-58

Appendix A

MMC-280 Rev.L 12-04 A-1

400 Series Standard Control Head Variations

MMC-329 Rev.C 8/03 A-5

MC2000 Series Standard Control Head Variations

MMC-307 Rev.G 8/03 A-11

700 Series Standard Control Head Variations

MMC-279 Rev.B 7/02 A-17

400 Series Weather Mount Enclosure

Deutsch Connector Assembly A-19

S-214 Rev.F 3/05 A-21

Automatic Power Selector (APS) Model: 13505

Drawing 11488D-1 Twin Screw Single APS Connection & Alternate Remote Switch A-23

Drawing 11488D-2 Twin Screw Dual APS Connections A-25

Drawing 11488D-3 APS Notes Page A-27

MMC-287 Rev.F 5/06 A-29

Grounding (Bonding)

MMC-288 Rev.E 8-03 A-31

References and Parts Source

MMC-165 Rev.E 2/05 A-33

Electronic Propulsion Control Systems Three Year Limited Warranty

MMC-163 Rev.C 10/04 A-35

Warranty Registration

Appendix B

B1 TROUBLESHOOTING GENERAL - - - - - B1-1

B1-1 Control System Examples B1-1

B1-1.1 785CE (Throttle Electronic, Clutch Solenoid or Clutch/Troll Solenoid, up to Four pluggable Stations) Processor B1-1

B1-2 Typical System Main Components B1-1

B1-2.1 Control Head B1- 1

B1-2.2 Processor B1-1

TABLE OF CONTENTS

B1-2.3	Power Source	B1-1
B1-2.4	Electrical Cables and Harnesses	B1-1
B2	TROUBLESHOOTING QUESTIONS - - - - -	B2-3
B3	TROUBLESHOOTING PROBLEM RESOLUTION - - - - -	B3-5
B3-1	DC Power	B3-5
B3-2	Component Location.	B3-5
B3-2.1	Control Heads.	B3-5
B3-2.2	Processors	B3-5
B3-3	Component Condition.	B3-5
B3-3.1	Control Heads.	B3-5
B3-3.2	Processors	B3-5
B3-4	Interconnecting Wiring and Harnesses	B3-5
Table 1:	Examples of Internal/External Components.....	B3-6
B4	TROUBLESHOOTING DIAGNOSTIC MENU - - - - -	B4-7
Figure 1:	Display Function Code	B4-7
Figure 2:	Display Troubleshooting Function	B4-7
Figure 3:	Display Function Blinking	B4-7
Figure 4:	Example Display of Applied Battery Voltage	B4-7
Figure 5:	Example Display of Tach Sensor Frequency	B4-7
Figure 6:	Example Display Control Head Lever Current Positions	B4-7
Figure 7:	Example Display Control Head Transfer Button Status View	B4-8
Figure 8:	Example Display of Software Revision Level View	B4-8
B5	TROUBLESHOOTING AUDIBLE TONES - - - - -	B5-9
B5-1	Basic Control System Tones	B5-9
B5-1.1	Slow Repetitive Tone	B5-9
B5-1.2	One Long - Three Short Tones	B5-10
Figure 9:	Display Examples of Remote Stations	B5-10
Figure 10:	Display Examples of Remote Stations A/D Values	B5-11
B5-1.3	Steady Tone	B5-11
B5-1.4	Three Second Steady Tone	B5-12
B5-2	Clutch Solenoid Control System Tones	B5-12
B5-2.1	One Long - One Short Tone	B5-12
B6	TROUBLESHOOTING REMOTE STATIONS - - - - -	B 6-13
B6-1	Transfer	B 6-13
B6-2	Command Signal	B 6-13
B6-3	A to D Counts	B 6-13
B6-4	Remote Station Select	B 6-14
Figure 11:	Display Station A/D's No Station Transfer Button Depressed	B 6-14
Figure 12:	Example Display Station A/D's Transfer Button Depressed for Stations 1 - 4	B 6-14
B6-5	Stuck Transfer Button	B 6-14
B7	TROUBLESHOOTING ERROR CODES - - - - -	-B7-15
Table 2:	Solenoid Clutch Error Codes.....	B7-15
Table 3:	Solenoid Troll Error Codes	B7-15
Table 4:	Basic Error Codes.....	B7-15

TABLE OF CONTENTS

B8 TROUBLESHOOTING BASIC PROBLEM CAUSES AND SOLUTIONS B8-18

Table 5: Solenoid Clutch Problem Causes and SolutionsB8-18
Table 6: Solenoid Troll Problem Causes and SolutionsB8-18
Table 7: Basic Control System Problem Causes and SolutionsB8-18

B9 TROUBLESHOOTING PROBLEMS WITHOUT ERROR CODES -B9-23

B9-1 Basic Control System Problems Without Error Codes B9-23
B9-2 Solenoid Clutch Problems Without Error Codes. B9-25
B9-3 Electronic Throttle Problems Without Error Codes. B9-25

B10 SYNCHRONIZATION TROUBLESHOOTING - - - - - B10-26

B10-1 Equal Throttle Synchronization B10-26
B10-1.1 Basic Troubleshooting. B10- 26
B10-2 Active Synchronization B10-26
B10-2.1 Basic Troubleshooting. B10- 26
B10-2.2 Electronic Throttle. B10-27

1 TROUBLESHOOTING WIRE HARNESSES - - - - - B11-29

1-1 Basic Control System Harnesses. B11-29
Table 8: Power, Start Interlock Harness Pin-OutB11-29
Table 9: Power, Start Interlock , Clutch Pressure Switch Harness Pin-Out.....B11-29
Table 10: Power, Start Interlock, Clutch Pressure Switch, and Alarm Harness Pin-OutB11-29
Table 11: Serial Communication Harness Pin-Out.....B11-30
Table 12: Control Head Harness Pin-Out.....B11-30
Table 13: Control Head Harness Hard-WireB11-30
Table 14: Tachometer Sensor Harness Pin-Out.....B11-31

B1-1 Clutch Harnesses. B11-31
Table 15: Power/Ahead/Astern Clutch Harness Pin-OutB11-31
Table 16: PowerAhead/Neutral/Astern Clutch Harness Pin-OutB11-31

B1-2 Clutch/Troll Harnesses B11-31
Table 17: Power/Ahead/Astern Clutch, Troll ON/OFF, and Troll Command Harness Pin-Out.....B11-31

B1-3 Throttle Harnesses B11-32
Table 18: Current/MAN Throttle Harness Pin-OutB11-32
Table 19: Frequency Throttle Harness Pin-Out.....B11-32
Table 20: PWM Throttle Harness Pin-Out.....B11-32
Table 21: Voltage Throttle Harness Pin-OutB11-32

**Service Field Test Unit
Reference Manual**

MM13927 Table of Contents MM13927--1
Revision List MM13927--2

MM13927-1 INTRODUCTION - - - - - MM13927-1-1

Figure 1: Service Field Test Unit (Break-out Box)MM13927-1-1
Figure 2: CruiseCommand Connector LocationsMM13927-1-1
Figure 3: Example of ClearCommand Pigtail LocationsMM13927-1-1

MM13927-2 PROCEDURE - - - - - MM13927-2-2

MM13927-2-1 Throttle Signal Testing MM13927-2-2

TABLE OF CONTENTS

MM13927-2-1.1 DC Voltage MM13927-2- 2
 Figure 4: Throttle Connection (DC Voltage)MM13927-2-2
MM13927-2-1.2 Current (mA) MM13927-2-2
 Figure 5: Throttle Connection (Current mA)MM13927-2-2
MM13927-2-1.3 PWM (Pulse Width Modulation) with DC Voltmeter MM13927-2-2
 Figure 6: Throttle Connection (PWM with DC VoltmeterMM13927-2-3
MM13927-2-1.4 PWM (Pulse Width Modulation) with Duty Cycle Meter MM13927-2-3
 Figure 7: Throttle connection (PWM with Duty Cycle Meter)MM13927-2-3
MM13927-2-1.5 Frequency (Hz.) MM13927-2-3
 Figure 8: Throttle Connection (Frequency Hz)MM13927-2-3

MM13927-3 CLUTCH PROCEDURE - - - - - MM13927-3-4

MM13927-3-1 TESTING MM13927-3-4
MM13927-3-1.1 Neutral Solenoid Testing MM13927-3-4
 Figure 9: Clutch Connections Neutral SolenoidMM13927-3-4
MM13927-3-1.2 Ahead Solenoid Testing MM13927-3-4
 Figure 10: Clutch Connections Ahead SolenoidMM13927-3-4
MM13927-3-1.3 Astern Solenoid Testing MM13927-3-4
 Figure 11: Clutch Connections Astern SolenoidMM13927-3-4

MM13927-4 TROLL PROCEDURES - - - - - MM13927-4-5

MM13927-4-2 TESTING MM13927-4-5
MM13927-4-2.1 Troll On/Off Solenoid MM13927-4-5
 Figure 12: Troll Connections Troll On/off SolenoidMM13927-4-5
MM13927-4-2.2 Troll Command (Proportional Solenoid) Testing with Amp Meter MM13927-4-5
 Figure 13: Troll Connections (Proportional Solenoid)MM13927-4-5

MM13927-5 2-SPEED TESTING - - - - - MM13927-5-6

MM13927-5-3 2nd Gear Disengaged MM13927-5-6
 Figure 14: 2-Speed ConnectionsMM13927-5-6
MM13927-5-4 2nd Gear Engaged MM13927-5-6

MM13927-6 PARTS LIST - - - - - MM13927-6-7

MMC-172 Rv Z-R 3-05 B-1
 FASSC International
MMC-151, Rev. Z-Z-I 9-05..... B-5
 Factory Authorized Service Centers - North America

Appendix C

Drawing 11748, Single Screw, Two StationsC-1
Drawing 11746, Single Screw, Two Pluggable Stations.....C-3
Drawing 11747, Twin Screw, Two Stations.....C-5
Drawing 11745, Twin Screw, Two Pluggable Stations.....C-7
Drawing 12230-1 Power Option #1C-9
Drawing 12230-2 Power Option #2C-11
Drawing 12230-3 Power Option #3C-13
Drawing 12230-4 Power Option #4C-15
Drawing 12230-5 Power Option #5C-17



REVISIONS LIST

Revision	Date	Revision Description
A.	9/01	1. Replaced Appendix B SER-165.
B.	11/01	Complete Manual revised to current ZF Mathers, LLC. standards 1. Revised Sections 3.7, 5.7, 6.3, (4.1 to 4.0), 6.3.4, 7.5, 9.1 2. Revised TRAIN-156
C.	2/02	Changes made per ELR 637, ECN 2556, 2574. 1. Revised Section 9.1 2. Revised Appendix A Parts List. 3. Revised Appendix B SER-165. Changes made per ELR 707 1. Revised Section 5.4.1 2. Revised Appendix B TRAIN-156 Changes made per ELR 694. 1. Revised Section 4.1
D.	5/02	1. Revised Section 4.1, Section 5.2.2, 5.2.3, 6.3.18 2. Revised Appendix A - Deutsch Manufacturers sheet and S-214 APS 3. Revised Appendix B - SER-165
E.	12/02	2. Revised Section 5.2.2 2. Revised Appendix A All forms. Added F-253 3. Appendix B Troubleshooting: Revised TRAIN-156 and SER-165. Removed TRAIN-157 and TRAIN-158, replacing with MM13927.
F.	5/03	SOFTWARE REVISED TO .1 Revised Sections: 1.1, 1.2, 1.3, 2.1, 2.3, 2.5, 2.6, 2.7, 2.7.3, 2.9, 3.2, 3.4.1, 4.2.1.1, 4.2.1.2, 4.2.2, 4.2.4, 4.2.5.1, 4.2.5.2, 4.4, 5.0, 5.1, 5.2, 5.3.3, 5.3.5, 5.3.7, 5.3.10, 5.3.13, 5.3.16, 6.3, 6.9, 7.3.1.1, 7.3.1.2, 7-6, 8.2, Added Sections: 5-3.5, 5.3.18, 6.10, Added Figures: (Section 3.2, Figure 15) Moved Sections: [2.10.1.2, 2.10.2 and 2.10.3, combined making them Section 2.10.1.2. Section 2.10.4 became Section 2.10.2.] [Moved Section 5.3.1 to be 5.3.2 Moving 5.3.2 to be 5.3.1.] Revised Figures: (Section 3.1, Figure 12:) (Section 3.2, Figure 13) Revised Tables: (Section , Table 1:) (Section 6.3, Table 4:) (Section 6.4.1, Table 5:) Appendix A - Replaced Service Sheets with most current Revision Levels Appendix B revised SER-165 and TRAIN-156. Appendix C added Drawings 12230-1 through 12230-5.
F	11/03	Manual revised to Current Forms. NOTE NEW ADDRESS AND PHONE NUMBERS.
G	3/05	Manual revised to New Company Name, Format, Current Forms, etc.
H	5/06	Manual brought up to ZF Marine Electronics current Format. ELR719 revised Start Interlock Contact rating changed to 7 amps. ELR1296 added Engine Stop Switch WARNING to OPERATION Section. Added Paramber A4 - Neutral Indication Tone Default Function Values updated per DVP .1E SW



1 INTRODUCTION

This manual is written to document every possible system option. Your system may not include every available option for single or multi-screw reverse reduction gear applications. Only those sections that apply to your specific installation are relevant to your vessel.

If additional options described within this manual are desired, contact your dealer for availability/compatibility with your system.

1-1 Manual Contents

This manual is divided into 12 Sections which cover, in detail, the features and operation of your system:

- Introduction (Section 1)
- Operation (Section 2)
- Plan the Installation (Section 3)
- Installation (Section 4)
- Set Up Procedures (Section 5)
- Dock Trials (Section 6)
- Sea Trials (Section 7)
- Control Options (Section 8)
- Periodic Checks and Maintenance (Section 9)
- ZF Marine Electronics Service Sheets (Appendix A)
- Troubleshooting (Appendix B)
- System Drawings (Appendix C)

1-2 Basic Theory of Operation

The CruiseCommand Marine Propulsion Control System will hereafter be referred to as CruiseCommand or System.

The System is electronic and requires a 12 or 24 VDC power supply, one Processor per engine/gear and one Control Head per remote station.

The CruiseCommand commands the vessel's throttle and shift using a single Control Head lever.

One wire harness/electric cable per Control Head lever connects the remote station(s) to the Processor(s). Only one remote station will have command at a given time and the Station-in-Command is indicated by a red light located on the Control Head. Station transfer is accomplished by pressing the Control Head mounted transfer button.

1-2.1 785CE Processor (Throttle - Electronic, Shift - Solenoid, Four Pluggable Remote Stations)

The System is designed for pleasure and light commercial marine vessels that require remote control of:

- electronic engine governors
- solenoid activated clutches or clutch/troll



1-3 System Features

1-3.1 Standard Processor Features

Further information regarding the following features can be found in Section 2 - OPERATION.

- Sequencing of Clutch and Engine Speed.
- Station-in-Command indication.
- Up to four Remote Stations.
- Command of up to five screws.
- Single Control Head lever command of speed and direction.
- Integrated Solenoid Trolling Valve Control.
- Start Interlock.
- Push Button Station Transfer.
- Emergency Reversal Protection.
- Warm-up Mode.
- High/Low Idle Selection.
- Engine Synchronization.
- One Lever Mode.

Further information regarding the following features can be found in Section 5 - SET UP PROCEDURES.

- Easily configured to a vessel's control requirements.
- Push Button Set Up.
- Pluggable Connections.

Further information regarding the following feature can be found in Appendix B4 - DIAGNOSTIC MENU.

- Visual system diagnostics, set up, and status indication.

Further information regarding the following feature can be found in Appendix B5 - AUDIBLE TONES.

- Audible system diagnostics and status indications.

1-3.2 Optional Processor Features

Further information regarding each optional feature can be found in Section 2 - OPERATION "Optional Features".

- System failure external alarm contact.
- Backup Control System
- Clutch pressure interlock.
- Multiple Screw installations.
- Station Expander (SE).



2 OPERATION

This Manual, as written, is intended for Single and Twin Screw applications only.

The Processor has the capability of controlling Triple, Quad and Quint Screw vessels. In order to do so, contact your ZF Marine Electronics representative for the required information and materials.

2-1 DC Power On

When DC power is turned ON to the Processor:

- A short steady tone, followed by an intermittent tone, will sound at all Remote Stations indicating that no station has command.
- The Start Interlock relay contact will remain open, preventing engine start.
- Throttle:
 - Electronic: The throttle signal will be commanded to Idle.
- Shift:
 - Solenoid: The Ahead and Astern shift solenoids will be de-energized, commanding Neutral.
- Troll:
 - Solenoid: The trolling valve solenoids are commanding lock-up.

2-2 Taking Command

The CruiseCommand Processor has four (4) Remote Station connectors available for pluggable Remote Station Control Head connection. If more Remote Stations are required, refer to Section 8 - CONTROL OPTIONS "Station Expander".

To take command at any one of the Remote Stations:

- Ensure all Control Head's lever(s) at that Station are in the Neutral detent (vertical position).

Figure 1: Station taking Command

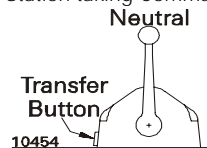

- Depress the transfer button for 1/2 second.

The Slow Repetitive tone will stop at all Stations, and the red LED indicator light will turn ON at the Control Head of the Station that had assumed command of the Control System.



NOTE: If Start Interlock is used: Once a Station is in command the Start Interlock relay contact will close, allowing the engine to start.



NOTE: Only one Station can have command at a time.

The Operator is now in control of the vessel's screws.



WARNING: An Engine STOP Switch MUST be installed at every remote operating station. Refer to CFR 46, Section 62.35-5 (US Coast Guard) and ABYC P-24.5.8.



2-3 Basic Operation

2-3.1 Normal Operating Mode

- The Control Head has three detents; Ahead, Astern and Neutral.
- With the Control Head lever positioned in the Neutral (vertical) detent, the Processor will command Neutral and the throttle at Idle revolutions per minute (RPM).
- Movement of the Control Head's lever 15 degrees to the Ahead or Astern detent will command Ahead or Astern clutch engagement, while the engine RPM remains at Idle.

Figure 2: Control Head Detents

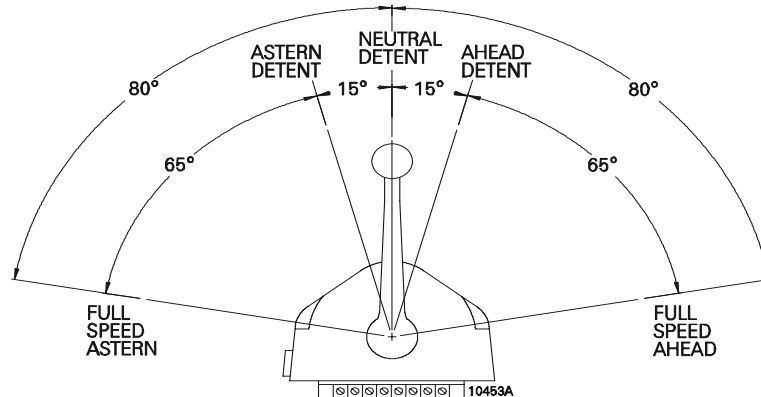

- Further movement of the Control Head lever through the next 65 degrees, will increase the engine RPM in proportion to the Control Head's lever position.

2-3.2 Trolling Valve (optional)



WARNING: Personal injury could occur if the following steps are not followed exactly.

This Control System is able to control electric Trolling Valves that utilize single or dual solenoids.

This System has two Modes of Operation when a Troll Valve Type of command has been set up: **Troll** and **Non-Troll**.

The Troll Mode option is selected during Set Up. When Troll Mode has been set up, the Control System will initially power up in **Non-Troll** Mode.

2-3.2.1 Operation in Non-Troll Mode

During **Non-Troll** Mode the Trolling valve will remain locked up, or at maximum oil pressure position. The System will work in Normal Operating Mode.

2-3.2.2 Operation in Troll Mode

2-3.2.2.1 Turn Troll ON

- Position the Control Head lever (s) in the Neutral, Ahead, or Astern detent.



NOTE: If System is set for Twin Screw or more operation, ensure all Control Head levers are in the same detent.

- Press and hold the transfer button for two (2) seconds.
 - The solid red indicator light on the Control Head will begin blinking rapidly, indicating the system is now in **Troll** Mode.



2-3.2.2.2 Operation

- A) Once in **Troll** Mode, movement of the Control Head's lever(s) to the Ahead or Astern detent, will begin to rotate the propeller at approximately 30% of Idle lock-up RPM.
- Transmission commands Ahead or Astern;
 - Throttle remains in Idle;
 - Control Head red LED flashing.
- B) Continued Control Head lever movement through the Troll Range:
- Will increase the propeller RPM from 30% shaft RPM to approximately 70% shaft RPM;
 - Throttle remains at Idle (or can be adjusted using **L4** to increase up to 20% of maximum throttle within this Troll Range).
 - Control Head red LED becomes a steady light when the Control Head lever reaches the end of the Troll Range.
- C) The remaining movement of the Control Head lever beyond the Troll Range:
- Clutch locks up;
 - Engine speed increases up to maximum throttle.

2-3.2.2.3 Turn Troll OFF

- A) Place the Station-in-Command Control Head lever in the Neutral, Ahead, or Astern detent.
- B) Press and hold the transfer button until the red indicator light on the Control Head changes (approximately 2 seconds) then release the button:
- When the red indicator light is a steady solid red, the Control system has Troll Mode OFF.
 - Clutch is locked-up.

2-4 Start Interlock (if used)

The engine start signal is blocked unless all of the following are true:

- DC power has been turned ON to the Control System.
- A Remote Station is in command.
- The Control System is commanding Neutral.

2-5 Station Transfer



WARNING: Personal Injury could occur if the following steps are not followed exactly.

Command can be transferred as follows:

- A) The Station-in-Command's lever(s) may be left in any position.



- B) Place the Control Head's lever(s) of the receiving Station in the Neutral/Idle detent position (refer to Figure 3:).

Figure 3: Remote Stations Before Transfer of Command

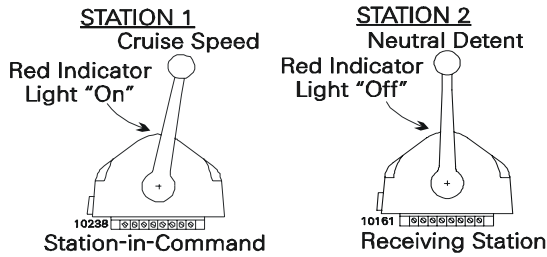
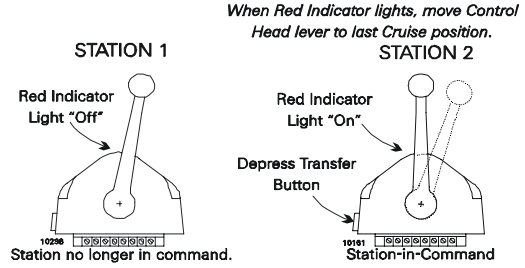

Figure 4: Remote Station Transfer after Transfer of Command



- C) At the Station taking command (Receiving Station), depress and hold the transfer button for 1/2 second (refer to Figure 4:).
- The red LED indicator light at the receiving Station's Control Head will illuminate, indicating that the Station has taken command.
 - The red LED indicator light will go OFF at the transferring Station's Control Head, indicating that the Station no longer is in command.
- D) The commanded positions of the Throttle and Clutch will remain unchanged for one second after the red LED lights. This allows the operator time to move the Control Head's lever(s) to a position approximately matching the last Station, which will allow the vessel to maintain present speed and direction.

2-6 Warm-up Mode (Throttle Only Mode)



WARNING: Personal Injury could occur if the following steps are not followed exactly.

This feature allows the operator to increase the engine's RPM, while the Clutch remains in Neutral. Warm-Up Mode is operational only when the Control Head lever is moved in the Ahead direction.

The system is placed into Warm-Up Mode as follows:

- A) At the Station-in-Command, ensure that the Control Head's lever is in the Neutral detent position (refer to the following Figure).
- B) Depress and hold the transfer button.
- C) After one second, move the Control Head's lever to the Ahead detent, while continuing to hold the transfer button.

Figure 5: Control Head Warm-Up Mode

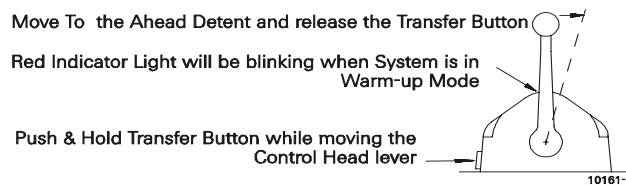
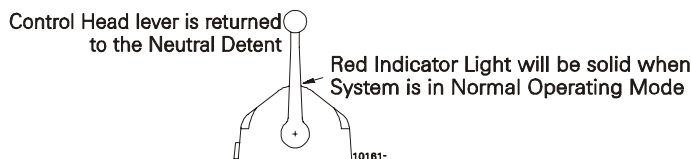

Figure 6: Control Head Normal Operating Mode



- D) Now release the transfer button.
- The red LED indicator light will blink slowly, indicating Warm-Up Mode is activated and the Clutch has remained at Neutral.



- E) The operator now can start the engine, if required, and increase the RPM through the entire throttle range by moving the Control Head's lever forward through the next 65 degrees.
- F) When the Control Head's lever is returned to the Neutral detent, the red LED will discontinue blinking and remain lit steady. After one second in Neutral, the Processor will automatically reset to normal operation with full control of the clutches and engine.
- G) The next movement of the Control Head's lever will engage the Ahead or Astern clutch (Normal Operation).

2-7 High/Low Idle

The Control System provides the input to the engine, so that it may run at the standard Idle speed (typically adjusted at the governor or carburetor), or it can provide a second elevated Idle speed.

2-7.1 Low Idle

- The factory default setting is for Low Idle Only.
- When the System is initially powered-up, it will always command Low Idle, even when High Idle is selected.

2-7.2 High Idle

- If High Idle is desired, it may be programmed during Dock Trials.
- High Idle is programmable up to a maximum setting of 20% of Full Throttle.

2-7.3 Selecting Between High and Low Idle



WARNING: Personal Injury could occur if the following steps are not followed exactly.

Refer to the following Figure when selecting between Low and High Idle (or vice versa) at the Station-in-Command.

- A) The Control Head's lever(s) may be in the Neutral, Ahead or Astern detents when making a selection.

Figure 7: High/Low Idle Mode Selection

Control Head levers may be in Neutral, Ahead, or Astern Detent.

Depress and Hold Transfer Button for 1/2 second to toggle between High and Low Idle

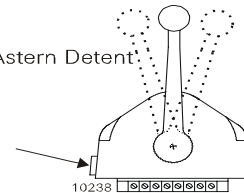

- B) Depress and hold the transfer button for 1/2 second and then release.
 - If the System was in Low Idle it will toggle to High Idle, and vice versa.
- C) To return to the previous Idle setting, depress and hold the transfer button again for 1/2 second and then release.

2-8 Engine Synchronization (Multi Screw)



NOTE: The Control System offers two types of synchronization, Active or Equal Throttle.

The Control System will always power-up with synchronization ON.



Synchronization is automatic and only operates when the Ahead clutch is engaged, consequently it can be left ON full time.

When synchronization has been selected during set up, the Control System will always power-up with synchronization ON.

In order for synchronization to become active (work toward synchronizing the engines' RPM's) the Synchronization Criteria listed below must be met.

2-8.1 Synchronization Criteria

Synchronization Criteria is met when all of the following are true:

- Both Control Heads must be commanding 5% or greater of the throttle range.
- The commanded throttles are within a 10% window of one another.
- Both Control Head levers are commanding Ahead clutch engagement.

2-8.2 Synchronization Types

The following types of synchronization use the same criteria, indications, and are turned ON and OFF as described in following Sections.

2-8.2.1 Equal Throttle Electronic Synchronization (default)

Equal Throttle synchronization simply has the Processors send the same or an equal throttle command signal to the engines when the criteria has been met.

With Equal Throttle Synchronization the Processors do not receive Tachometer signals representative of the Engine's RPM's.



CAUTION: The Control system will remain synchronized as long as the control Head's levers are in close proximity to one another. If a lever is moved to a point where the 10% throttle window is exceeded, a 10% increase in engine RPM would occur with one engine, resulting in a sudden change in the vessel's direction.

2-8.2.2 Active Synchronization

Active Synchronization must be enabled during Set Up and a Tachometer Sensor Wire Harness must be used.

The Processors each receive a tachometer signal representing engine RPM from their respective engines. These signals are compared with one another over a serial communication line. If the Synchronization Criteria is met, the throttle command signal of the engine(s) running at the higher RPM is lowered, until the RPM's of all engines match.

2-8.3 Synchronization Indications

The green LED located on the Control Head indicates the status of synchronization.

- When the green LED is lit **steady**, the engines are synchronized.
- When the green LED is **not lit**, the engines are not synchronized and the Control System is not attempting to do so.
- The green LED **blinks** when the Control system is working toward synchronization.

2-8.4 Turning Synchronization OFF/ON when Criteria is Met

2-8.4.1 Turning OFF:

When the Criteria is met, synchronization is automatic and does not need to be turned ON. If the operator elects to turn OFF synchronization, follow the steps below:



- A) Ensure that the Control Head's levers are positioned to a point where Synchronization Criteria are met.
- B) At the Station-in-Command, press and hold the transfer button until the green LED **blinks twice** and then goes out (approximately 2 seconds).
- C) Synchronization is now OFF.

2-8.4.2 Turning ON:

Synchronization is automatic and does not need to be turned ON, unless previously turned OFF, as described in the previous Section.

- A) Ensure that the Control Head's levers are positioned to a point where Synchronization Criteria are met.
- B) At the Station-in-Command, press and hold the transfer button until the green LED **lights** (approximately 2 seconds).
 - The green LED will blink as the system is working toward synchronization.
 - The green LED will become solid when the engines are synchronized.

2-9 One Lever Mode (Multi Screw)



NOTE: One Lever Operation may be used in Troll Mode or in Non-Troll Mode.



NOTE: The Green LED will always be lit while in One Lever Operation, no matter which position the Master Control Head lever is in.

The system supports a mode of operation referred to as One Lever Mode.

One Lever Mode allows the operator to control two to five engines and transmissions with a single Control Head lever. Any of the Control Head levers at any Remote Station can be designated by the operator as the **Master lever**.

The designation can be changed by the operator at any time. Most of the features (synchronization, troll, etc.) available in normal operation are available while operating in One Lever Mode.

- The Processor defaults to One Lever Mode disabled.
- One Lever Mode can be disabled or enabled in the Set Up Procedures.
- When One Lever Mode is enabled, the operation must be turned ON and OFF as described below.



WARNING: Personal Injury could occur if the following steps are not followed exactly.

2-9.1 Turning ON One Lever Operation

Figure 8: Step A) One Lever Operation Mode

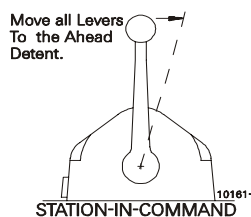
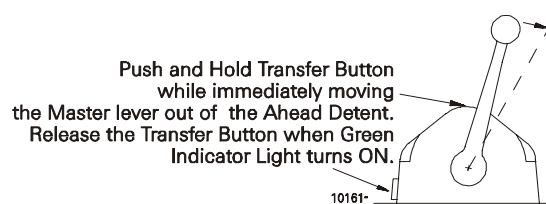

Figure 9: Step B) One Lever Operation Mode



- A) At the Station-in-Command, move all the Control Head levers to the Ahead detent.



- B) Depress and **Hold** the transfer button **while** moving one of the Control Head levers forward, out of the Ahead detent. **Do Not Release the Transfer Button** until the green LED turns ON, indicating One Lever Operation is now active.
- The Control Head lever which the operator chose to move out of the Ahead detent, becomes the **Master lever**.
 - The Control Head lever which was left in the Ahead detent is now inactive.



NOTE: The Control Head lever(s) designated by the operator to be inactive in One Lever Operation, may be left in the Ahead detent or moved fully forward. Moving the lever fully forward is recommended, because it moves it out of the way and prevents accidental bumps while operating.

2-9.2 Turning OFF One Lever Operation



WARNING: It is strongly recommended that the Master lever be returned to the Neutral/Idle position prior to turning OFF One Lever Operation.

- Do not attempt to transfer command from one Remote Station to another while in One Lever Operation. Always turn One Lever Operation OFF prior to transferring.
- Failure to observe these recommendations may result in a sudden change in the vessel's direction.

- A) Place the **Master lever** into the Neutral detent.
- B) Place all inactive Control Head levers into the Neutral detent.
- Whenever an inactive lever(s) is moved to the Neutral detent, One Lever Operation is turned OFF for that lever ONLY!
 - In applications with three or more screws, the green LED will not turn OFF until all inactive Control Head levers are returned to the Neutral detent.

2-10 Optional Features

2-10.1 External Alarm Capability

- This optional feature is designed to provide a status signal to an external visual or audible alarm circuit.
- The status signal is in the form of an OPEN or CLOSED relay contact. When the contact is CLOSED, the Processor is functioning normally. When the contact OPENS, this indicates the software program has quit running due to a component failure or loss of DC power.
- A full explanation is provided in Section 8 - CONTROL OPTIONS.

2-10.2 Auxiliary Backup Control System

The Backup Control System (BU Sys) provides a control system which is fully independent from the ZF Marine Electronics Control System. The BU Sys can control the transmission as well as the engine, but it does not include ZF Marine Electronics control logic, safety interlock, and timing circuits. In other words, there is **no protection** for operator errors, such as shifting into gear at elevated rpm's.

If this option is going to be used, please contact a ZF Marine Electronics Representative for further information.

2-10.3 Clutch Pressure Interlock

- The purpose of the Clutch Pressure Interlock is to prevent high engine RPM when the Clutch is not fully engaged.
- A full explanation is provided in Section 8 - CONTROL OPTIONS.



2-10.4 Multiple Screw Installations

This Manual, as written, is intended for Single and Twin Screw applications only.

The Processor has the capability of controlling Triple, Quad and Quint Screw vessels. In order to do so, contact your ZF Marine Electronics representative for the required information and materials.

2-10.5 Station Expander (SE)

- The SE is a separate Processor housed in an enclosure that allows the connection of up to five additional Remote Control Stations.
- The SE communicates with the Processor over the serial communication line.
- A full explanation of the installation, operation and adjustment of the SE is provided in the Installation Manual provided with the SE.

If this option is going to be used, please contact a ZF Marine Electronics Representative for further information.



3 PLAN THE INSTALLATION



NOTE: ZF Marine Electronics recommends that the system be installed in accordance with ABYC, E-11 and P24.

3-1 System Requirements

The first step when installing a System is to carefully plan the installation. This includes finding proper mounting locations for the Processor(s) and Control Heads. The decision must be made on where power is going to be sourced and how the power will be routed to the Processor(s).

Once the locations have been decided, lengths of electrical wiring and Harnesses must be determined.

Figure 10: Processor

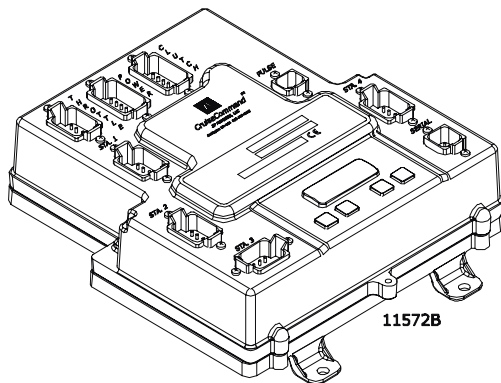

The Processor receives the variable DC voltage from the Control Head(s) and converts these inputs to the appropriate electronic or electric outputs at the correct time and sequence to the Governor and Gear Box. The information regarding throttle type, throttle/gear sequencing, etc., are all stored on memory within the Processor.

Only when the locations and lengths of wiring/harnesses have been determined, should you start the actual installation. The following sections describe the requirements for installing the components and selecting mounting locations.

3-1.1 Processor(s)

Processors required per engine:

Single Screw: One (1) Processor

Twin Screw: Two (2) Processors

Mounting Hardware is installer supplied.

Installation/Troubleshooting Manual is included with the Processor.

The following items must be taken into account when selecting the location for the Processor(s):

- The Processor is spray proof, but not water proof. Therefore, an area must be selected that typically stays dry.
- The engine room is the preferred location for mounting the Processor.
- If the engine room is too small, locate in any area where it is easily accessible, as long as all of the criteria listed are met.
- Bulkhead mounting is the preferred method due to ease of access for wiring and adjustments. However, the Processor can be mounted in any attitude as long as the Display LED window and push buttons are accessible.
- Do not mount the Processor on the engine, transmission, or in any location that will subject it to excessive vibration.



- Do not mount the Processor to the transom when the vessel is equipped with a surface piercing drive system (due to vibration concerns).
- Locate the Processor(s) away from sources of high heat, such as engine exhaust manifolds or turbochargers. Allow 4 feet (1,2m) of clearance or more.
- Do not mount the Processor(s) in close proximity to gas engine ignition systems, alternators, generators or any equipment producing strong magnetic fields. Allow 4 feet (1,2m) clearance or more.



CAUTION: Strong magnetic fields can influence the Processor's electronic circuits and void your warranty.

- Grounding (Bonding) is required for maximum electromagnetic compatibility (EMC) performance. A threaded hole is provided for connection to the vessel's grounding system.

3-1.2 Control Head(s)

Refer to Appendix A - Control Head Variations Service Sheets for information on the various Control Heads available and their dimensions.

- Control Heads are available with pluggable pigtails or may be hard-wired (no pigtails).
- Retrofit applications may require an Adapter Pad to cover the old Control Head cutout. A variety of Adapters and Cover Pads are available. If an Adapter/Cover Pad is required, please contact a ZF Marine Electronics Representative for further information.
- The Control Head can be mounted at any location on the vessel, as long as all of the criteria listed above are met.
- A HandHeld is available to use, instead of a mounted Control Head. Refer to the Installation Manual supplied with the HandHeld for additional information on the planning of the installation.
- Ensure that the clearance is sufficient for the Control Head's lever to reach full Ahead and full Astern.
- The 400 and MC2000 Series Control Heads are spray proof from the top, but must be protected from the weather on the underside.
- When a 400 or MC2000 Series Control Head must be mounted in a location where the underside may be exposed to the weather, consider using a Weather Mount Enclosure. Refer to the Appendix A - Weather Mount for specific information.
- The 700 Series Control Heads are fully water proof.

3-1.3 Wire Harnesses

For further information regarding Wire Harness requirements, contact a ZF Marine Electronics Representative.

The following lists the various Harnesses that plug into the Processor:

Table 2: is a general list of Wire Harnesses available for CruiseCommand. Not all of the harnesses may be used on every system. The use of the harness depends on the features being used on the vessel. All Harnesses are available from ZF Marine Electronics, LLC.



Station 2, Station 3, Station 4, Pulse, and Serial connectors on the Processor are sealed with plugs at the factory. If the connectors are to be used, remove and discard these plugs. Every connector should either have a Wire Harness or plug. Do not leave a connector empty.

Table 2: Processor Harness Connector Locations

No.	Description
1	Throttle Harness
2	Power/Start Interlock/Clutch Pressure (optional)/ Alarm Circuit (optional) Harness
3	Clutch Wire Harness or Clutch/Troll Wire Harness (or optional MAN with Troll or MAN without Troll Wire Harness)
4	Control Head Wire Harness
5	Serial Communication Wire Harness (Multi Screw)
6	(Pulse) Tachometer Sensor Wire Harness (Multi Screw using Active Synchronization only)

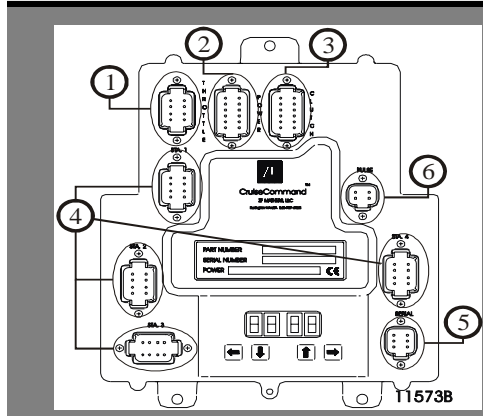

Figure 11: Harness Plug Connectors
Depress & Hold

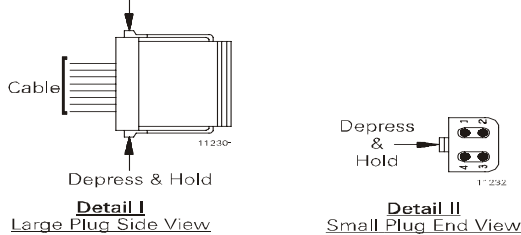
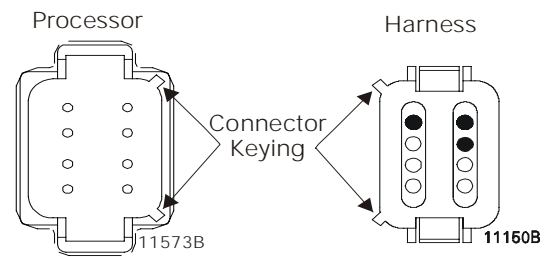

Figure 12: Processor Connector and Harness Plug Keying



The Harnesses use one or both of the plug connector types detailed in Figure 11:.

When connecting the plugs, ensure that the release button or buttons are depressed and held until plug is fully connected or disconnected.

Ensure the harness plug connector is in the appropriate orientation, using the keying on the connectors, before connecting to the Processor.

Connecting or disconnecting plugs without depressing and holding the release button or buttons will damage the plug.

3-1.3.1 Control Head Harnesses

- One Control Head Harness is required for every Control Head lever at every Remote Station.
- The Control Head Harnesses are available in various lengths.
- Harnesses are available with plugs on both ends or a plug on the Processor end only.
- The Harness from the Port side of a Control Head is always routed to the Port Processor.
- The Harness from the Starboard side of a Control Head is always routed to the Starboard Processor.

3-1.3.2 Power, Start Interlock, Clutch Pressure (optional), Alarm (optional) Harness

- One Harness required per Processor.
- The Harness is plugged at the Processor end only.



- In addition to the required DC power and Start Interlock, the Harness has options for Clutch Oil Pressure Switch and External Alarm Circuit that are available.
- All of the cables in the Harness are the same length. Therefore, order a length that will reach all of the previously mentioned items, if required.
- The Harness is available in lengths up to 30 feet (9,14m) for 12 VDC systems, and up to 60 feet (18,2m) for 24 VDC systems.

3-1.3.3 Serial Communication Harness

The Serial Communication Harness is only required in:

- Multi Screw applications,

The Harness interconnects the Processors to each other. A plug is attached at both ends of the Serial Harness.

Twin Screw:

One (1) Serial Harness (part no. 13316-X)

3-1.4 Additional Harnesses

For further information regarding Wire Harness requirements, contact a ZF Marine Electronics Representative.

The following lists the additional Harnesses that plug into the Processor:

3-1.4.4 Clutch Harness

- One Harness required per Processor.
- The Harness consists of 3 two-conductor cables for Ahead and Astern Clutch Solenoids and Clutch Power.

3-1.4.5 Clutch/Troll Harness

- One Harness required per Processor.
- The Harness consists of:

2 two-conductor cables for Ahead and Astern Clutch Solenoids.

2 two-conductor cables for Troll ON/OFF and Troll Proportional Solenoids.



NOTE: Some transmissions only utilize one solenoid for troll, therefore, the harness would consist of only three cables.

1 two-conductor cables for Power.

- The Power for the clutches and troll are supplied by the Processor's power source.
- All of the cables in the Harness are the same length. Therefore, order a length that will reach all of the previously mentioned items, if required.

3-1.4.6 Throttle Harness

- One Harness required per Processor.
- There are 4 types of Throttle Harnesses: Voltage, Current, PWM (Pulse Width Modulation), and Frequency.
- Most Throttle Harnesses are plugged at the Processor side only.
- Some Throttle harness types are available with plugs on both ends.



3-1.4.7 Tach Sensor Harness

There are two Tach Sensor Harnesses available:

- 1 The first is the AC Coupled Sensor Harness, which is designed for inputs from items such as Mechanical Senders, Magnetic Pickup Sensors, the Alternator AC Stator Terminal or the negative Coil Terminal.
- 2 The second Harness is designed for Active Sensors with an Open Collector output, such as Hall Effect Sensors.
 - This Harness is only required when Active Synchronization is required.
 - One Harness per Processor is required.
 - The Harness is plugged on one end only.

Determine the source of the tachometer signal, which can be provided by a mechanical tachometer sender, magnetic pickup, alternator's pre-rectified output, the negative side of the coil (gasoline engine) or an engine's electronically produced signal. Refer to Engine Tachometer Sender Requirements located in Appendix A.

3-2 Tachometer Sensors

There are two types of Tachometer Sensors available through ZF Marine Electronics, Mechanical (p/n 8902) and Magnetic Pickup (p/n 8912). Both types provide two separate outputs, one for the tachometer(s) and the second output provides the Processor's tachometer signal requirement. If a sensor other than one supplied by ZF Marine Electronics is used, it must meet the criteria provided below for each type:

3-2.1 AC Coupled Sensors

- The signal must have a minimum amplitude of +/- 1.5 V (3.0 V P-P).
- The signal's maximum amplitude must not exceed +/- 100 V (200 V P-P).
- The frequency of the signal must be no lower than 30 Hz at Idle.
- The signal's frequency may not exceed 8 KHz at Full Throttle.

3-2.2 Alternator

- The pre-rectified stator AC terminal may be used as the tach source.
- The signal is inputted to the AC Coupled Sensor input.
- The signal must meet the same criteria as any AC Coupled Sensor Signal (refer to Section 3-2.1).

3-2.3 Point side of the Coil

- When the signal is sourced from the coil or an electronically produced tach signal (used on some gasoline engines) the signal is connected to the AC Coupled Sensor input.
- The signal must meet the same criteria as any AC Coupled Sensor Signal (refer to Section 3-2.1).

3-2.4 Active Sensors (Open Collector Output)

- The sink current ability of the Sensor may be no lower than 2 mA.
- The operational current may not exceed 50 mA.
- The Sensor must have a maximum saturation voltage of 0.8 V.
- An operational voltage requirement of 9- 10 VDC.
- A minimum frequency of 5 Hz at Idle.
- A maximum frequency of 8 KHz at Full Throttle.



3-3 Installer Supplied Tools And Parts

3-3.1 Required Tools

Screwdriver – medium Phillips, #2.

Wire cutter, stripper & crimper (Thomas & Betts model WT-2000 or equivalent).

Saw with blade suitable for Console Top Panel.

Drill Motor with 9/32 inch and 7/32 inch drill bits.

Hole saw - 1 inch (25,4mm)

3-3.2 Optional Tools

Calibrated Digital Multimeter (Fluke 80 Series or equivalent).

Service Field Test Unit (P/N 13927, available through ZF Marine Electronics)

Field Test Control Head - Dual (P/N 14000)

3-3.3 Engine Stop Switch

An engine STOP switch MUST be located at each Remote Station.



WARNING: An Engine STOP Switch MUST be installed at every remote operating station. Refer to CFR 46, Section 62.35-5 (US Coast Guard) and ABYC P-24.5.8.

3-4 DC Power Source

One of the most important (and often overlooked) items for proper operation of your control system is a clean, dedicated, and reliable source of DC Power.

The wiring used to supply power from the power source (battery) through the various components (fuses, distribution panel, relays, etc.) to the Processors must be sized for a voltage drop of 10% or less using 10 amps as the maximum current draw. Refer to **ABYC** Standard E-11, Table X to determine the appropriate wire gauge for the necessary conductor length.

When using ZF Marine Electronics supplied 14 gauge power cable, and in accordance with **ABYC** Standard E-11, the distance from a 12 volt power source (battery or DC Distribution Panel) shall not exceed 30 feet (9,1m). In 24 volt systems, the maximum cable length is 60 feet (18,2m).

ZF Marine Electronics highly recommends using an Automatic Power Selector (APS) and a second power source (battery) to supply power to each Processor. Refer to Appendix A - Automatic Power Selector (APS) for examples of power supplies.

3-4.1 Processor Power

The items listed below will help ensure optimum performance from your control system.

- The Processor requires a battery source of 12 or 24 VDC.
- Two 5 ampere (when isolated power supplies are required) or one 10 ampere trip-free thermal circuit breaker(s) with manual ON/OFF actuation
- The use of an APS (Automatic Power Selector) is strongly recommended.
- Power should come from the vessel's DC Distribution Panel.
- The cables feeding power from the battery to the Processor must be sized large enough to keep voltage drop, due to current flow, below 10%. Reference Appendix A - Automatic Power Selector (APS) .



Contact a ZF Marine Electronics representative for the Processor's power cable(s) maximum lengths. Refer to Appendix A - Automatic Power Selector for examples of the various wiring options. Ultimately, it is the boat builder or installer's responsibility to ensure that the vessel's wiring meets the requirements of American Boating & Yachting Council standard E-11, for AC and DC Electrical Systems on Boats.

3-4.2 Clutch Power

The power for the Clutch Solenoids may come from the same or different power source as Processor power if isolation is required. The Clutch Power Supply cable and the Processor DC Power Supply cables may come from the same 10 amp circuit breaker or in the case of isolated power, from two separate 5 amp circuit breakers. Refer to Appendix C - System Drawings for actual requirements.



4 INSTALLATION



NOTE: Before starting the actual installation of the Control System, make sure you have the correct parts and tools on hand. Refer to Section 3 - PLAN THE INSTALLATION. Read ALL the instructions pertinent to each part before beginning the installation of the part.



NOTE: When connecting the plugs, ensure that the release buttons are depressed and held until plug is fully connected. To disconnect the plugs, the release buttons **MUST** be held depressed until plug is disconnected.



NOTE: When installing the harness cable, support the cables using clamps or straps not more than 18 inches (0,5m) apart, unless contained in a conduit. Install each cable so it is protected from physical damage. Refer to ABYC Standard.

4-1 Processor

Figure 13: Processor Dimensions

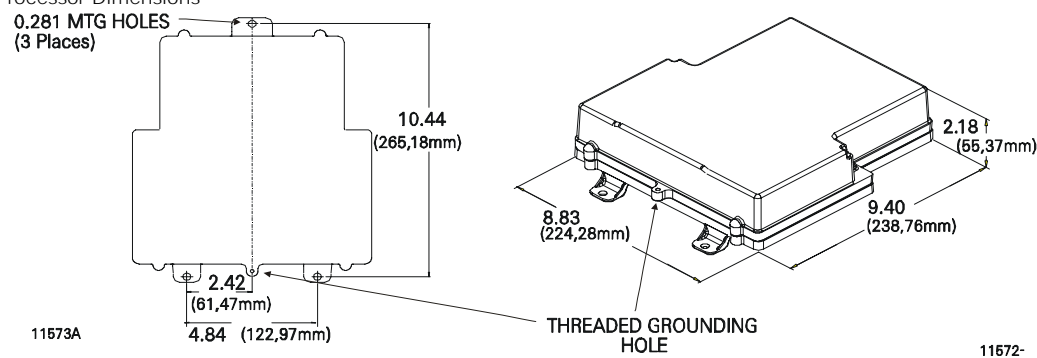

- A) Place the Processor on the mounting surface and mark the three (3) screw holes.
- B) Remove Processor and drill the screw holes.
- C) Secure the Processor to the mounting surface with three 1/4 inch or M6 fasteners.
- D) Connect the Processor to the Hull or Grounding Bus by running a 12 AWG or larger wire between the Processor's threaded grounding hole and the Grounding Bus. (The Processor is grounded if mounted directly to a metallic surface that is connected to a metal hull) (Refer to Appendix A - Grounding)

4-2 Control Head(s)

4-2.1 400, MC2000 and 700 Series Control Heads

Refer to the appropriate Control Head Dimensions and Variations Service Sheet in Appendix A for installation.



NOTE: The one connector Control Head harness requires a modification at the Control Head connections. Refer to the Appendix A - Control Head Sheet's 7-conductor Control Head connections.

4-2.2 500 Series Control Heads

Refer to the Installation Manual supplied with the 500 Series Control Head Assembly for installation instructions.

4-2.3 Handheld Remote Controls

Refer to the Installation Manual supplied with the Handheld Remote for installation instructions.



4-3 Wire Harness Installation

Four different styles of plugs and connectors are utilized but are inserted in an identical fashion as follows:

4-3.1 Harness Plug Insertion and Extraction

- A) Prior to inserting the Harness plug, pay close attention to the number of pins and the keying of the plug. The plug is designed to be inserted one way only into the connector, but can be incorrectly forced together in the opposite orientation.
- B) When connecting the plugs, ensure that the locking mechanisms are depressed and held until the plug is fully connected or disconnected.

4-3.2 Standard Control Head Harness

Depending on whether a pluggable or hard-wired (not pluggable) Control Head(s) is selected, will determine the procedure for terminating the Harness at the Remote Station.

- The first installation procedure is written for the pluggable Control Head(s).
- If a hard-wired Control Head(s) is selected, follow the information provided in the second procedure.



IMPORTANT: The distance of the Control Head from the Processor is limited to the length of an UNINTERRUPTED Harness. This cable should NEVER be spliced.



NOTE: Multi Screw, Control Heads must be connected to the same numbered Station on all Processors.

4-3.2.1 Control Head Harness with Two Connectors

- A) At the Port Processor, insert the plug into the **STATION 1** connector.
- B) Run the cable to the Control Head located at Station 1.
- C) Insert the Harness plug into the Control Head's Port pigtail plug.
- D) Ensure that the cable has a strain relief close to the Control Head to relieve the strain on the connections.
- E) Repeat Steps A) thru D) for the Starboard Processor.
- F) Repeat Steps A) thru E) with the rest of the Remote Stations.



NOTE: When Stations 3, 4 and 5 are to be installed, they each require the removal of the watertight seal located on the Processor enclosure in the Station cable entry holes.

4-3.2.2 Control Head Harness with One Plug

- A) At the Port Processor, insert the plug into the **STATION 1** connector.
- B) Run the cable to the Port side of the Control Head located at Station 1.
- C) Connect the conductors to the Control Head as described in the appropriate Control Head Dimensions and Variations Service Sheet in Appendix A.
- D) Provide a strain relief in close proximity to the Control Head's terminal block.
- E) Repeat Steps A) thru D) for the Starboard Processor.
- F) Repeat steps A) thru E) with the rest of the Remote Stations.



NOTE: When Stations 3, 4 and 5 are to be installed, they each require the removal of the watertight seal located on the Processor enclosure in the Station cable entry holes.



4-3.3 Standard Power/Start Interlock/Alarm(optional)/Clutch Pressure Switch(optional) Harness

The Power Harness has a minimum of two cables (DC Power and Start Interlock) and may have two more optional cables (Clutch Pressure Interlock and External Alarm Circuit).

This Harness has one plug, which is inserted in the Processor's POWER connector.



CAUTION: The most common source of trouble is loose wiring connections.

- Verify wiring connectors are properly crimped and cannot be pulled out.
- Crimps and connections must be made to conductor wire, NOT to the wire insulation.
- Verify all screwed wire connections are secure.

Continue with the following Sections that apply to this application.

4-3.3.1 DC Power Cable



WARNING: When connecting the Power Harness to the Processor, be sure the power is OFF

It is critical to design and wire the Control system in a manner which provides the cleanest power source possible. This can be accomplished by providing two power sources, along with an APS. The preferred system is a dedicated circuit with no other accessories or functions. (Refer to Appendix A - Automatic Power Selector)

- Run the cable labeled POWER to the DC Distribution Panel or the optional Power Relay.
- Strip back the appropriate amount of PVC jacketing and conductor insulation.
- Crimp the appropriate connectors to the conductors.
- Terminate the conductors to the DC Power Source.

4-3.3.2 Start Interlock Cable



CAUTION: The Processor is designed for a maximum of 5 amperes, maximum 50 volt, start signal current. Greater current will damage the interlock circuit.

Figure 14: Start Interlock Connections

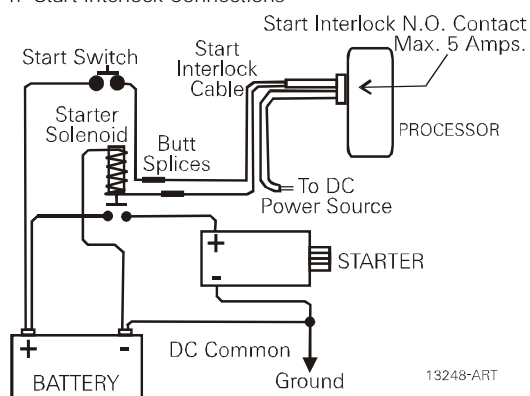

- Run the cable labeled START INTERLOCK to the Engine's Starter Solenoid.
- Disconnect the Starter Switch wire from the Solenoid.
- Strip back the appropriate amount of PVC jacketing and conductor insulation.
- Connect one of the conductors to the Solenoid's Starter Switch terminal.
- Butt splice the second wire to Starter Switch wire.

4-3.3.3 External Alarm Circuit (optional)

Refer to Section 8 - CONTROL OPTIONS, for installation information.

4-3.3.4 Clutch Pressure Switch (optional)

Refer to Section 8 - CONTROL OPTIONS, for installation information.



4-3.4 Serial Communication Harness (Multi Screw)

The CruiseCommand System's default method of synchronization is "Equal Throttle". With this type of synchronization the Processors ensure that the SAME or an EQUAL Throttle Command Signal is applied to both governors when the Synchronization Criteria has been met. Though this is not "true" Synchronization, in most cases it is very effective.

If "true" Synchronization is required, or requested, "Active" Synchronization would need to be selected during SET UP. "Active" Synchronization requires a tachometer signal representative of each engines' RPM. The frequency of these signals are measured and changes to the Processor's throttle command signal outputs are made until all engines are running at the same RPM.

4-3.4.1 Twin Screw Serial Communication (Required for both Synchronization Types)

- A) At the Processors, remove the watertight plug-in cap from the SERIAL connector and discard.
- B) At the Port Processor, insert the Serial harness's plug into the SERIAL connector.
- C) Run the harness to the Starboard Processor.
- D) Insert the plug into the Starboard Processor's SERIAL connector.
- E) Secure the Serial Harness at least every 18 in. (45,72 cm).

4-3.4.2 Tachometer Sensor (Required for Active Synchronization Only)

- A) At the Processors, remove the watertight plug-in cap from the PULSE connector and discard.
- B) At the Port Processor, insert the Tach Sensor harness's plug into the PULSE connector.
- C) Run the Port Tach Sensor Harness cable to the Tach signal source of the Port engine.
- D) Connect the conductors to the Port Tach source as indicated by the Engine Manufacturer's documentation. Keep in mind that some sources are polarity sensitive. **(black wire - negative, red wire - positive)**
- E) Repeat B) through D) for the Starboard side.

4-3.5 Additional Harnesses

4-3.5.1 Throttle Harness



IMPORTANT: Ensure all Processors are using the same kind of Wire Harness and that it matches the Engine Selection to be applied in Section 5 - SET UP PROCEDURES.

The Processor connects directly to the engine interface using a Throttle Wire Harness.

- A) Connect the plug end of the Harness into the THROTTLE connector at the Processor.
- B) Run the cable to the appropriate engine interface. (Example: Port to Port, etc.)
- C) Refer to the engine documentation for termination points at the engine interface.
- D) Repeat steps A) thru C) on all Processors.

4-3.5.2 Clutch Harness

The Clutch Harness is supplied with three (3) or four (4) cables extending from the plug. One cable is supplied for each of the following:



- Ahead Clutch solenoid
 - Astern Clutch solenoid
 - Power
 - Neutral Clutch solenoid (optional)
- A) Insert the Clutch Harness plug into the CLUTCH connector on the Processor. (Example: Port to Port, etc.)
- B) Run all the cables, except the one labeled POWER, to the appropriate transmission.
- C) Refer to the Transmission documentation for termination at the solenoids.

4-3.5.3 Clutch/Troll Harness

The Clutch/Troll Harness is supplied with three (3) or more of the following cables:

- Ahead Clutch solenoid (Refer to "Clutch Harness" Section)
 - Astern Clutch solenoid (Refer to "Clutch Harness" Section)
 - Power (Refer to "Clutch Harness" Section)
 - Neutral Clutch solenoid (optional) (Refer to "Clutch Harness" Section)
 - Troll Command solenoid
 - Troll ON/OFF solenoid
- A) Insert the Clutch/Troll Harness plug into the CLUTCH connector on the Processor.
- B) Run all the cables, except the one labeled POWER, to the appropriate transmission.
- C) Refer to the Transmission documentation for termination at the solenoids.

4-4 Engine Stop Switches

An engine stop switch(s) must be located at all Remote Stations and capable of stopping the engine at any RPM.

The Installer supplies the Stop Switches. Refer to the installation instruction supplied with the switch and the engine installation instructions for manufacturers recommendations.



WARNING: An Engine Stop Switch at each Remote Station is an absolute requirement. Refer to CFR 46, SEC. 62.35-5 and ABYC P-24.5.8.



5 SET UP PROCEDURE

The Processor utilizes push buttons in conjunction with Display LED's to program, adjust, calibrate and set up the various features. The push buttons also allow you to access and display information regarding the health of the System.

The following paragraphs explain how to locate and use the push buttons and Display LEDs:

5-1 Processor Components Used In Set Up

Figure 15: Processor Display LED and Arrow Push Buttons

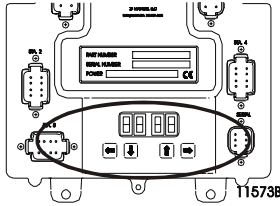

Each Processor has a Display LED and Arrow Push Buttons located on the front cover. (Refer to Figure 15:)

- The **Display LED** is to view the Function Codes and Values. It consists of four 7-segment display pads.
- The **Arrow Push Buttons** are used to scroll through and select the Function Codes, and set the Values.

5-1.1 Processor Display LED

Figure 16: Display LED at Normal Operation

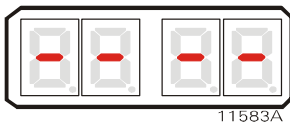
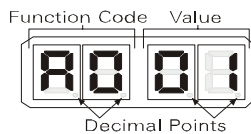

Figure 17: Display LED Designations



- The Processor's Display LED has four 7-segment LED's, which light up to show either letters or numbers.
- The Display LED during Normal operation has running red center dash lines (Figure 16:)
- The first two digit Display LED's to the left, indicate the **Function Code**, which is alphanumeric.
- The second two digit Display LED's indicate the numeric **Value** that is currently programmed into the Processor for the Function Code displayed to the left.
- A **decimal point** indicator is located on the bottom right corner of each Display LED. (Figure 17:)

5-1.2 Push Buttons

Figure 18: Arrow Push Buttons



There are four Push Buttons with arrows located below the Display LED on the Processor cover. These push buttons are used to scroll through, select, and store the Functions and Values. The direction of the arrow indicates "Left", "Down", "Up", and "Right".

5-1.2.1 "Up" and "Down" Push Buttons

Pressing the "Up" or "Down" Push Buttons *once* has the following functions:

- Stops Normal Operation Display (running red center dash lines) and activates the **Function Menu**.
- While in the **Function Menu**, scrolls through the Function Codes one at a time.
- When in Set Up Mode, increases (Up) or decreases (Down) the Function Value one digit at a time.
- When an Error Code is displayed, scrolls through the error messages one at a time.



NOTE: Refer to Appendix B - TROUBLESHOOTING ERROR CODES for steps to be taken for Error Messages.



5-1.2.2 "Left" and "Right" Push Buttons

Pressing and **holding** the "Left" and "Right" Push Buttons *at the same time* has the following functions:

- Activates Set Up Mode as indicated by the blinking Display LED. (Operator must hold the buttons down until the blinking begins, then release.)
- While in Set Up Mode, deactivates Set Up Mode, saves the displayed Value to memory, and returns to the **Function Menu**. (Operator must **hold** the buttons down until the blinking stops, then **release**.)

5-1.2.3 "Left" Push Button Only

Pressing the "Left" Push Button **once** has the following functions:

- Deactivates Set Up Mode WITHOUT any changes to the Function Value stored in memory. (Operator must **hold** the button down until function code stops blinking, then **release**.) The previously saved Function Value will then be displayed.
- While in **Function Menu**, changes the Display LED to the **Error Menu**, if any errors are present. (has no effect if there are no errors stored)
- While in the **Error Menu**, changes the Display LED back to the **Function Menu**.

Figure 19: Error Menu Example



5-1.2.4 "Right" Push Button Only

Pressing the "Right" Push Button **once** has the following function:

- While in the **Error Menu**, clears inactive errors. (Active errors blink, inactive do not)

Pressing and **holding** the "Right" Push Button has the following function:

Figure 20: Display LED Four Digit Value

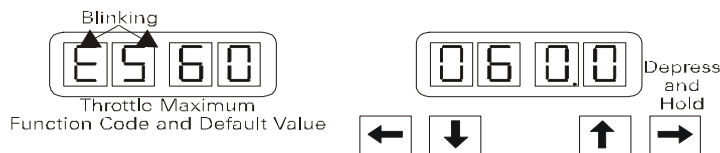

- While in Set Up Mode, or **Function Menu**, allows the Function Value of the current Function Code to be displayed with all four Display LEDs.

5-2 Activating Set Up Mode



NOTE: To **Escape** from the Set Up procedure at any time without saving the changed value to memory, depress the "Left" **Arrow Push Button** **once**. The Function Code will stop flashing and the Function will be saved with the original Value.

- The Display LED is in Normal operating condition with the running red center dash lines.
- Depressing either the "Up" or "Down" Arrow Push Button will **ACTIVATE** the **Function Menu**.
- Depressing the "Up" or "Down" Arrow Push Button will **SCROLL** through the **Function Menu** Function Codes, one at a time.
- Once the desired Function Code is visible on the Display LED, press and **hold** the "Left" and "Right" Arrow Push Buttons *at the same time*, until the Function Code begins to blink. This will activate Set Up Mode.
- Depressing the "Up" Arrow Push Button will **INCREASE** the Value of the Function, while pressing the "Down" Arrow Push Button will **DECREASE** the Value of the Function. (Pressing and **holding** the "Up" or "Down" Arrow Push Button will **INCREASE** or **DECREASE** the Function Value rapidly.)



5-3 Storing Values To Memory

Once the desired Value has been reached in Set Up Mode, the Value is stored to memory as follows:

- A) Depress and **hold** the "Left" and "Right" Arrow push buttons until the Function Code stops blinking.
 - The new Value is now programmed into memory.
 - Set Up Mode is exited.
- B) Depress the "Up" or "Down" Arrow Push Button until the next required Function Code is reached.
- C) Reactivate Set Up Mode. Refer to Section 5-2.



NOTE: If no Push Buttons are pressed for five (5) minutes, the selected Mode of operation is automatically exited and the System returns to Normal Operating Mode. If no Push Buttons are pressed for five (5) minutes while in Set Up Mode, it will be exited without the changes stored to memory

5-4 Function Codes And Values

The following tables list the Function Codes' Name, Default Value and Range or available Options. **Each of the Function Codes are explained in further detail in the following sections.**



NOTE:

SINGLE SCREW APPLICATIONS: The Function Values may be entered and stored in any order.

MULTI SCREW APPLICATIONS: The **A1** Function must be set **FIRST**, and the **A0** Function must be set **SECOND**. The rest of the Function Values may be entered and stored in any order.

Once these parameters are set, either cycle power to the Processors or wait five (5) minutes, before continuing set up.



CAUTION: If ZF Hurth Gears are used, set the **L1** parameter as the next setting **AFTER** the **A1** and **A0** parameters have been set.



NOTE: Once these parameters are set, either cycle power to the Processors or wait five (5) minutes, before continuing set up.

Table 3: Processor Function Codes

Function Code	Function Name	Default Value	Value Range or Options
A0	Processor Identification	01	01, 02, 03, 04, 05
SET FUNCTION A0 AFTER THE A1 FUNCTION CODE HAS BEEN SET. Each Processor MUST have a unique Processor ID #.			
A1	Number of Engines	01	01, 02, 03, 04, 05
IN MULTI SCREW APPLICATIONS, THE A1 FUNCTION CODE IS TO BE THE FIRST (1ST) PARAMETER SET.			



IMPORTANT: If ZF Hurth Gears are used, set the **L1** parameter after **A1** and **A0**.

A2	One Lever Operation	00	00 - Disabled 01 - Enabled
A3	Station Expander (SE)	00	00 - Disabled 01 - Enabled

DO NOT ADJUST THE ABOVE FUNCTION! Leave at default Value set by the Factory. Contact a ZF Marine Electronics Authorized Technician If this Function requires adjustment.



A4	Neutral Indication Tone	00	00 - No Tone 01 - Tone upon Control Head engaging Neutral 02 - Tone upon Transmission shifting to Neutral
-----------	-------------------------	----	---

Table 4: Electric Throttle Function Codes

Function Code	Function Name	Default Value	Value Range or Options
E0	Engine Throttle Profile	06	1 - Caterpillar (PWM) (8 to 92%) 02 - Cummins Centry (Voltage)(0.9 to 4.5 VDC) 03 - Cummins Quantum(Voltage)(0.9 to 1.2- 4.0 VDC) 04 - Detroit Diesel (Voltage) (0.64 to 4.65 VDC) 05 - MTU or MAN (Current) (4.0 to 20.0 mA) 06 - Scania (Voltage) (0.42 to 2.95 VDC) 07 - John Deere (Voltage) (0.5 to 4.5 VDC) 08 - Volvo (Voltage) (0.6 to 3.6 VDC) 09 - Detroit Diesel 1800 (Frequency)(120.64 to 360.9 Hz) 10 - Detroit Diesel 2300 (Frequency) (120.64 to 463.5 Hz)
** DEFAULT BASED ON THROTTLE PROFILE SELECTED.			
E1	Throttle in Neutral	**	01.0% to 25.0% of Throttle Range [Throttle Range = Throttle Max (E3) - Throttle Min (E2)]
E2	Throttle Minimum	**	1.0% to 97.0% Must be 3% or more below Throttle Maximum (E3)
E3	Throttle Maximum	**	04.0% to 100.0% of Maximum Throttle Allowable. Must be 3% or more above Throttle Minimum (E2)
E4	Throttle Maximum Astern	100.0	01.0 to 100.0% of Throttle Maximum (E3)
E5	Throttle Pause Following Shift	00.5	00.0 to 05.0 Seconds
E6	High Idle	00.0	00.0 to 20.0% of Throttle Maximum (E3).
E7	Active Synchronization	00.	00 – Disabled 01 - Enabled

Table 5: Clutch Function Codes

Function Code	Function Name	Default Value	Value Range or Options
C0	Clutch Pressure Interlock	00	00 – Not Installed 01 – Installed 02 – Throttle Clutch Pressure Interlock Mode
C1	Clutch Interlock Delay	01.0	00.5 to 10.0 Seconds
C2	Proportional (Reversal) Pause	00	00 – In-Gear; 01 – Neutral
C3	Proportional (Reversal) Pause Time	03	00 to 99 Seconds
C4	Proportional (Reversal) Pause Ratio	00	00 – 2:1 Ahead to Astern vs. Astern to Ahead 01 – 1:1 Ahead to Astern vs. Astern to Ahead

Table 6: Trolling Valve Function Codes

Function Code	Function Name	Default Value	Value Range or Options
L0	Troll Enable and Control Head Troll Lever Range	00	00 – No Troll 01 – 20 Degrees- Type 1 02 – 35 Degrees- Type 2 03 – 45 Degrees- Type 3 (Throttle limited to 75% of Throttle Range)
The following L1 parameter MUST be the THIRD Function set if ZF Hurth Gears are used.			



L1	Troll Valve Function	00	00 - Normal, (No Current when at Lock-up) 01 - Inverse (No Current when at Lock-up) 02 - Normal (Maximum Current when at Lock-up) Preset for ZF220-550, 12VDC Systems. 03 - Normal (No Current when at Lock-up) Preset for ZF220-550, 24VDC Systems. 04 - Normal (No Current when at Lock-up) Preset for ZF2000, 24 VDC Systems. 05 - Inverse (No Current when at Lock-up) Preset for ZF600, 1900 and 2500, 24VDC Systems. 06 - Preset for 12VDC ZF Hurth Systems with two (2) proportional solenoids. 07 - Preset for 24VDC ZF Hurth Systems with two (2) proportional solenoids
L2	Troll Minimum Pressure	10.0	01.0 to 99.0% Must be at least 1% more or less than Troll Maximum (L3) [DEPENDING on whether Normal or Inverse is selected].
L3	Troll Maximum Pressure	10.0	02.0% to 100.0% Must be at least 1% more or less than Troll Minimum. (L2) [DEPENDING on whether Normal or Inverse is selected].
L4	Troll Throttle Limit	00	00 to 20% of Troll Maximum (L3)
L5	Troll Pulse Duration	00	00.0 to 09.9 Seconds.
L6	Troll Pulse Percentage	25.0	00.0 to 100.0%
L7	Lock Up Percentage (Hurth Only)	45 (L106) 60 (L107)	00.0 to 100.0% Used only when L106 or L107 is selected.

Table 7: Troubleshooting Function Codes

Function Code	Function Name	Default Value	Value Range or Options
H0	Diagnostic	none	Input Voltage (+/- 0.5VDC) Tachometer Sensor Frequency Lever A/D, Stations 1, 2, 3, & 4 Transfer Button, Stations 1, 2, 3, & 4 Software Revision Level
H1	Erase EPROM	none	Return to Factory Defaults (For Authorized Personnel Only)
H2	Driver Fault Detection Enable	00	00 - None Enabled Allows the Processor to monitor the clutch and/or troll solenoids.

5-5 Field Service Test Unit (Break-out Box) and Multimeter Use

Refer to Appendix A - MM13927 Manual for more information on the use of the Field Service Test Unit (Break-out Box).

To aid in adjusting the following list of Processor signals, ZF Marine Electronics recommends the use of a ZF Marine Electronics Field Service Test Unit (P/N 13927) (Break-out Box) and a calibrated Multimeter.

Table 8: Electric Throttle Functions requiring Field Service Test Unit and Multimeter

Code	Function Name	Code	Function Name
E1	Throttle in Neutral	E4	Throttle Maximum Astern
E2	Throttle Minimum	E6	High Idle
E3	Throttle Maximum		



Table 9: Solenoid Trolling Functions requiring Field Service Test Unit and Multimeter

Code	Function Name	Code	Function Name
L2	Trolling Minimum	L4	Troll Throttle Limit
L3	Trolling Maximum		

5-6 System Programming And Adjustments



NOTE:

SINGLE SCREW APPLICATIONS: The Function Values may be entered and stored in any order.

TWIN SCREW APPLICATIONS: The **A1** Function must be set **FIRST**, and the **A0** Function must be set **SECOND**. The rest of the Function Values may be entered and stored in any order.

IF ZF HURTH GEARS ARE USED: Set L1 Function after the A1 and A0 Functions are set.

Once the above Functions are set, either cycle power to the Processors or wait five (5) minutes, before continuing Set Up Procedures.



NOTE: Power must be turned ON to the Processors when programming or making any adjustments to the System.



NOTE: In order to prevent nuisance alarms when first setting up a System, some Function Codes take up to 5 minutes to become ACTIVE. The Functions affected by this are the functions that rely on Serial Communication, such as **A0**, **A1**, **A2**, **A3**, **E7**, and **L0**. Cycling power OFF, then ON, expedites these features making the Functions available immediately.

5-6.1 Processor Functions

5-6.1.1 Function Code A1 – Number of Engines

The total number of engines must be entered into the memory of each of the Processors. All Processors in an installation must have the SAME VALUE entered.

The available Values for this Function are:

- 01 Single Screw (Default Value)
- 02 Twin Screw
- 03 Triple Screw (if required, contact a ZF Marine Technician.)
- 04 Quad Screw (if required, contact a ZF Marine Technician.)
- 05 Quint Screw (if required, contact a ZF Marine Technician.)



NOTE: If Processors are not connected by a serial communication cable, leave the **A1** function code at Default Value.



NOTE: Twin screw or more applications require Function Code **A1** Value to be changed on ALL Processors prior to changing the Value of Function Code **A0**.

To change the Value (Refer to Sections 5-2 and 5-3, page 5-2):

- A) Scroll to Function Code **A1**.
- B) Activate Set Up Mode.
- C) Scroll Up or Down to the desired Value.
- D) Store the Value to memory.
- E) Repeat on all Processors before proceeding to the next Function.

Figure 21: Display LED Function A1

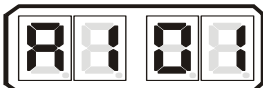



5-6.1.2 Function Code A0 – Processor Identification



NOTE: In twin screw or more applications, the Value of Function Code **A0** can be changed only AFTER the Value in Function Code **A1** has been changed to **02** or higher on ALL Processors.

In applications where there is more than one screw, the system must know which Processor is where. Every Processor must have its OWN UNIQUE identifying number. At NO time can two or more Processors be identified by the same Processor Identification Number.

The available Values for this Function are:

00 (Default Value), **01**, **02**, **03**, **04** and **05**.



NOTE: If Processors are not connected by a serial communication cable, leave the **A0** function code at Default Value.

To change the Value (Refer to Sections 5-2 and 5-3, page 5-2):

Figure 22: Display LED Function A0

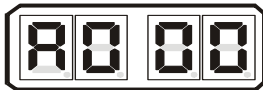

- A) Scroll to Function Code **A0**.
- B) Activate Set Up Mode.
- C) Scroll Up or Down to the desired Value.
- D) Store the Value to memory.
- E) Repeat on all Processors before proceeding to the next Function.



NOTE: Before continuing set up, wait 5 minutes or cycle power.



NOTE: If ZF Hurth Gears are used, set the **L1** parameter next.

5-6.1.3 Function Code A2 – One Lever Operation

In Twin Screw or more applications, the System has the ability to command all engines and transmissions to the same speed and direction with a single Control Head lever. This Function allows this Feature to be enabled or disabled. (Refer to Section 2 - OPERATION, for operating instructions)

The available Values for this Function are:

- 00** Disabled
- 01** Enabled (Default Value)

To change the Value (Refer to Sections 5-2 and 5-3, page 5-2):

Figure 23: Display LED Function A2



- A) Scroll to Function Code **A2**.
- B) Activate Set Up Mode.
- C) Scroll Up or Down to the desired Value.
- D) Store the Value to memory.



5-6.1.4 Function Code A3 – SE (Station Expander)



NOTE: This Manual does not go into detail on the Station Expander installation and adjustments. For further information on the Station Expander, refer to Section 8 - CONTROL OPTIONS or contact your local ZF Marine Electronics Representative.

The SE is a separate unit, which gives the System the ability to increase the number of Remote Stations.

The available Values for this Function are:

00 Disabled (Default Value)

01 Enabled

Contact ZF Marine Electronics if this Function Code is going to be changed from the default setting.

5-6.1.5 Function Code A4 – Neutral Indication Tone

This Function allows the installer to turn ON a 1/2 second, low frequency tone to indicate Neutral.

The available Values for this Function are:

00 Disabled (Default Value)

01 Tone sounds when the Control Head's lever reaches Neutral.

02 Tone sounds when the Processor commands the Transmission to Neutral.

To change the Value (Refer to Sections 5-2 and 5-3, page 5-2):

- A) Scroll to Function Code **A4**.
- B) Activate Set Up Mode.
- C) Scroll Up or Down to the desired Value.
- D) Store the Value to memory.

Figure 24: Display LED Function A4



5-6.2 Throttle Functions

The following Throttle Functions are set up in Section 6 - DOCK TRIALS:

Table 10: Throttle Functions Performed during Dock Trials

Code	Function Name	Code	Function Name
E1	Throttle in Neutral	E4	Throttle Maximum Astern
E2	Throttle Minimum	E5	Throttle Pause Following Shift
E3	Throttle Maximum	E6	High Idle

5-6.2.6 Function Code E0 – Electric Engine Throttle Profile

This Function, in combination with the Throttle Harness type, configures the throttle output profile to meet the specifications of these various engines.

The available Values for this Function are listed below:

- 01** - Caterpillar (PWM) (8 to 92%)
- 02** - Cummins Centry (Voltage) (0.9 to 4.5 VDC)
- 03** - Cummins Quantum (Voltage) (0.9 to 1.2 - 4.0 VDC)
- 04** - Detroit Diesel (Voltage) (0.64 to 4.65 VDC)
- 05** - MTU or MAN (Current) (4.0 to 20.0 mA)
- 06** - Scania (Voltage) (0.42 to 2.95 VDC)
- 07** - John Deere (Voltage) (0.5 to 4.5 VDC)



- 08 - Volvo (Voltage) (0.6 to 3.6 VDC)
- 09 - Detroit Diesel (Frequency) (120.64 to 360.9 Hz)
- 10 - Detroit Diesel (Frequency) (120.64 to 463.5 Hz)

The Default Value is set to 06 Scania Profile.

To change the Value (Refer to Sections 5-2 and 5-3, page 5-2):

Figure 25: Display LED Function E0



- A) Scroll to Function Code E0.
- B) Activate Set Up Mode.
- C) Scroll Up or Down until the desired Value is displayed.
- D) Store the Value to memory.

5-6.2.7 Function Code E7 – Active Synchronization

This Function Code selects the type of Synchronization. The types are described in Section 2 - OPERATION .

The available Values for this Function are:

- 00 Disabled (DEFAULT)
- 01 Enabled

To change the Value (Refer to Sections 5-2 and 5-3, page 5-2):

Figure 26: Display LED Function E7

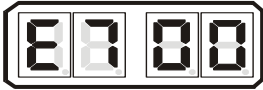

- A) Scroll to Function Code E7.
- B) Activate Set Up Mode.
- C) Scroll Up or Down to the desired Value.
- D) Store the Value to memory.

5-6.3 Clutch Functions

The following Clutch Functions are set up in Section 7 - SEA TRIALS:

Table 11: Basic Clutch Functions Performed during Sea Trials

Code	Function Name	Code	Function Name
C2	Proportional (Reversal) Pause	C3	Proportional (Reversal) Pause Time

5-6.3.1 Function Code C0 – Clutch Pressure Interlock

This adjustment is to be set to Enabled only if the optional Clutch Pressure Switch is being used with this application.

This Function enables or disables the feature and allows for two different modes of behavior when a Clutch Pressure Switch is used. Refer to Section 8 - CONTROL OPTIONS, for detailed information.

The available Values for this Function are:

- 00 Not Installed (Default Value)
- 01 Installed
- 02 Throttle Clutch Pressure Interlock Mode



NOTE: The C002 value is recommended in Gear Boxes that take longer than 10 seconds to reach operating pressure. Refer to Section 8 - CONTROL OPTIONS for more information on the settings.

To change the Value (Refer to Sections 5-2 and 5-3, page 5-2):



Figure 27: Display LED Function C0

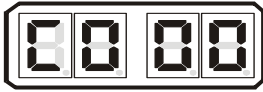

- A) Scroll to Function Code **C0**.
- B) Activate Set Up Mode.
- C) Scroll Up or Down to the desired Value.
- D) Store the Value to memory.

5-6.3.2 Function Code C1 – Clutch Interlock Delay

This adjustment is to be set to Enabled only if the optional Clutch Pressure Switch is being used with this application.

This Function works together with Function Code **C0** – Clutch Pressure Interlock. Refer to Section 8 - CONTROL OPTIONS, for further information.

The available Values are **00.5** to **10.0** seconds. The Default Value is **01.0** seconds.

To change the Value (Refer to Sections 5-2 and 5-3, page 5-2):

Figure 28: Display LED Function C1

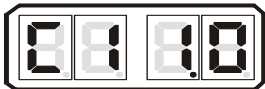

- A) Scroll to Function Code **C1**.
- B) Activate Set Up Mode.
- C) Scroll Up or Down to the desired Value.
- D) Store the Value to memory.

5-6.3.3 Function Code C4 – Proportional Pause Ratio

This Function Code selects whether the Proportional Pause Time is the same in Ahead and Astern or whether the time in Ahead is twice that in Astern.

Standard vessels with a bow and a stern typically select a pause which is twice as much in Ahead compared to Astern. This is because much more speed is obtainable in Ahead, then Astern. Consequently, more time is required to slow down from Ahead as compared to Astern.



NOTE: When the Controls are installed on a vessel such as a double ended Ferry or the Controls are being used to control a thruster, the proportional pause should be the same in Ahead as Astern or Port and Starboard in the case of a Thruster.

The available Values for this Function are:

00 2:1 Ahead to Astern vs. Astern to Ahead (**Default Value**)

01 1:1 Ahead to Astern vs. Astern to Ahead

00 - 2:1 Ratio

- This is the default setting. This function determines how the value set during Sea Trials for **C3** - Proportional Pause Time, is applied.
- The number of seconds selected is for an Ahead to Astern maneuver only. An Astern to Ahead maneuver will be one-half of the **C3** -Proportional Pause Time selected. This is the typical selection since most vessels do not reach the same throttle in Astern as they would in Ahead.

Therefore, the time required to get to a sufficient water speed for a safe reversal is significantly less.

01- 1:1 Ratio

- When this setting is selected, the value set during Sea Trials for **C3** - Proportional Pause Time is the same for both Ahead to Astern, as with Astern to Ahead maneuvers.



- This may be selected when the vessel reaches the same water speed in both directions, as would be the case with a Double Ended Ferry. Another application where this option may be selected would be the control of a Bow or Stern Thruster.

To change the Value (Refer to Sections 5-2 and 5-3, page 5-2):

Figure 29: Display LED Function C4

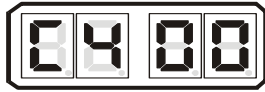

- Scroll to Function Code C4.
- Activate Set Up Mode.
- Scroll Up or Down to the desired Value.
- Store the Value to memory.

5-6.4 Troll Functions

The following Troll Function is set up during Dock Trials for ZF Hurth Transmissions only. Refer to Section 6 - DOCK TRIALS:

Table 12: Troll Function Performed during Dock Trials

Code	Function Name
L7	Lock Up Percentage (ZF Hurth Only)

The following Troll Functions are set up during Sea Trials. Refer to Section 7 - SEA TRIALS:

Table 13: Troll Functions Performed during Sea Trials

Code	Function Name	Code	Function Name
L2	Troll Minimum Pressue	L5	Troll Pulse Duration
L3	Troll Maximum Pressure	L6	Troll Pulse Percentage
L4	Troll Throttle Limit		



IMPORTANT: If ZF Hurth Gears are used, set the L1 parameter after A1 and A0.

5-6.4.4 Function Code L0 – Troll Enable and Control Head Lever Troll Range

There are three types which can be used to control any trolling valve. The available Values are:

- 00 = No Trolling Valve (Normal Operating Mode) **DEFAULT**
- 01 = **Type 1** 20 degrees Troll Range
- 02 = **Type 2** 35 degrees Troll Range
- 03 = **Type 3** 45 degrees Troll Range



NOTE: When Troll Type 3 is selected, maximum throttle is limited to 75%

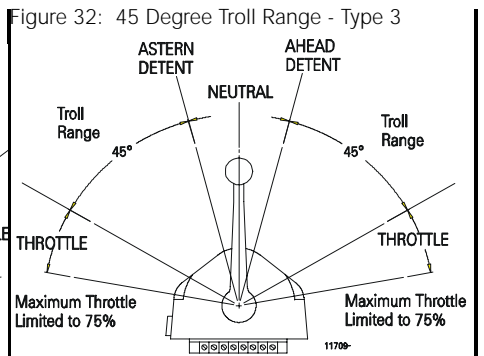
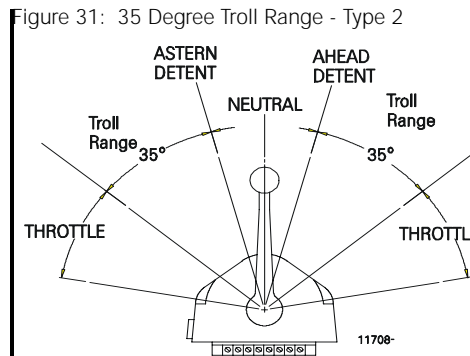
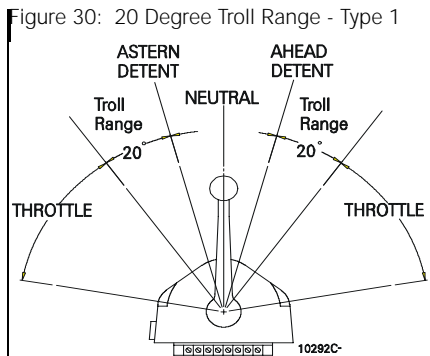

To change the Value (Refer to Sections 5-2 and 5-3, page 5-2):



Figure 33: Display LED Function L0

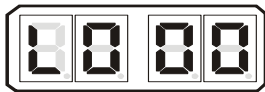

- A) Scroll to Function Code **L0**.
- B) Activate Set Up Mode.
- C) Scroll Up or Down to the desired Value.
- D) Store the Value to memory

5-6.4.5 L1 - Solenoid Troll Valve Function



CAUTION: This feature **MUST** be entered and set **AFTER** A0 - Processor Identification, if ZF Hurth Gears are used. All other features may then be entered and set in any order.

Refer to Table 14: to select the correct set up for the trolling valve used with this application.

The manner in which the current signal to the Proportional Valve behaves is determined with this function.

Table 14: Solenoid Trolling Valve Function **L1** Type Selection

VALUE	TROLL VALVE		DESCRIPTION
00	Normal	Reintjes ZF 550 and lower	(DEFAULT) When selected, the current to the Proportional Valve increases as Clutch pressure increases. When Lockup (Full Pressure) is selected, the current drops to 0.
01	Inverse	Twin Disc 6000 Series ZF 600 and higher	When selected, the current to the Proportional Valve increases as Clutch pressure increases. When Lockup (Full Pressure) is selected, the current drops to 0.
02	Normal	ZF 220 - 550 12 VDC	When selected, the current to the Proportional Valve increases as Clutch pressure increases. When Lockup (Full Pressure) is selected, the current drops to 0. Preset for ZF 220 - 550 12 VDC Systems.
03	Normal	ZF 220 - 550 24 VDC	When selected, the current to the Proportional Valve increases as Clutch pressure increases. When Lockup (Full Pressure) is selected, the current drops to 0. Preset for ZF 220 - 550 24 VDC Systems.
04	Normal	ZF 2000 24 VDC	When selected, the current to the Proportional Valve decreases as Clutch pressure increases. When Lockup (Full Pressure) is selected, the current drops to 0. Preset for ZF 2000 24 VDC Series Systems.
05	Inverse	ZF 600, 1900, 2500 24 VDC	When selected, the current to the Proportional Valve decreases as Clutch pressure increases. When Lockup (Full Pressure) is selected, the current drops to 0. Preset for ZF 600, 1900, or 2500 24 VDC Series Systems.
06		ZF Hurth 12 VDC	Preset for 12 VDC ZF Hurth Systems.
07		ZF Hurth 24 VDC	Preset for 24 VDC ZF Hurth Systems.

To change the Value (Refer to Sections 5-2 and 5-3, page 5-2):

The default value is **00**.

Figure 34: Display LED Function L1

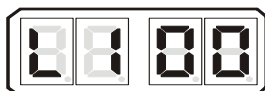

- A) Scroll to Function Code **L1**.
- B) Activate Set Up Mode.
- C) Scroll Up or Down to the appropriate Value for the Trolling Valve.
- D) Store the Value to memory

5-6.5 Troubleshooting Functions

5-6.5.1 Function Code H0 - Diagnostics

This Function is used during troubleshooting and is explained in detail in Appendix B - TROUBLESHOOTING DIAGNOSTIC MENU.

5-6.5.2 Function Code H1 – Return to Factory Defaults

This Function may be used during troubleshooting.

(Do not make any adjustments to this Function Code, unless directed to do so by ZF Marine Electronics Service or Engineering Departments).



5-6.5.3 Solenoid Troubleshooting Functions

5-6.5.3.1 Function Code H2 - Driver Fault Detection Enable

The H2 Function is available only on Processors with integrated Clutch and/or Troll Solenoid command.

The Processor can be programmed to monitor the current flow through the Clutch and/or Troll solenoid. When this option is selected, if the current level is too high or too low, an alarm is sounded and an Error Code is produced.

Table 15: lists the required value that needs to be entered for Function Code H2, to monitor the Ahead, Astern, Neutral clutch solenoids and the Troll Command and On/Off.

Table 15: Solenoid Error Status Enable

Value	Ahead	Astern	Neutral (optional)	Troll Command	Troll On/off
00	off	off	off	off	off
01	ON	off	off	off	off
02	off	ON	off	off	off
03	ON	ON	off	off	off
04	off	off	ON	off	off
05	ON	off	ON	off	off
06	off	ON	ON	off	off
07	ON	ON	ON	off	off
08	off	off	off	ON	off
09	ON	off	off	ON	off
10	off	ON	off	ON	off
11	ON	ON	off	ON	off
12	off	off	ON	ON	off
13	ON	off	ON	ON	off
14	off	ON	ON	ON	off
15	ON	ON	ON	ON	off
16	off	off	off	off	ON
17	ON	off	off	off	ON
18	off	ON	off	off	ON
19	ON	ON	off	off	ON
20	off	off	ON	off	ON
21	ON	off	ON	off	ON
22	off	ON	ON	off	ON
23	ON	ON	ON	off	ON
24	off	off	off	ON	ON
25	ON	off	off	ON	ON
26	off	ON	off	ON	ON
27	ON	ON	off	ON	ON
28	off	off	ON	ON	ON
29	ON	off	ON	ON	ON
30	off	ON	ON	ON	ON
31	ON	ON	ON	ON	ON



NOTE: Function Codes **32** through **63** are reserved for future expansion and should not be used at this time.



6 DOCK TRIALS



WARNING: It is imperative that the information provided in the previous Sections have been **READ** and **FOLLOWED** precisely, **PRIOR** to attempting a Dock Trial.



NOTE: On multiple screw applications, the following tests must be performed on all Processors. If any of the following tests fail, consult Appendix B Troubleshooting.

6-1 Control Heads (Engines Stopped)

- A) Turn power ON to the Control System.
- B) The Control Head at each Remote Station should produce an intermittent tone.
- C) Take command at a Remote Station.
- D) Perform each of the following steps on all Remote Stations.
 - 1 Move the Control Head's lever(s) full Ahead and full Astern. Ensure that there are no obstructions to the movement, the Processor reacts to the lever movement, and that no tones are generated.
 - 2 Place the Control Head's lever(s) in the Neutral position.
 - 3 Depress and hold the Station transfer button while moving the Control Head's lever(s) to the Ahead detent. Release the transfer button.
 - The red LED on the Control Head should blink, indicating Warm-up Mode has been entered. Warm-up Mode only operates in the Ahead direction.

If the red indicator light BLINKS, continue with the testing. If the red indicator light DOES NOT BLINK, check connections as stated in the appropriate Appendix A - Control Head Service Sheet.

6-2 Start Interlock (Engines Stopped)

- A) Turn the Processor DC power OFF.
 - Verify that the engine(s) will not start.
- B) Turn Processor DC power ON. Do not take command at a Remote Station.
 - Verify that the engine(s) will not start.
- C) Take command at a Remote Station. Place the Control Head's lever(s) to approximately 50% of the throttle range.
 - Verify that the engine(s) will not start.
- D) Place the Control Head's lever(s) in the Neutral/Idle position. Take command at a Remote Station.
 - Verify that the engine(s) will start in this position.

If any of the above tests fail, verify Start Interlock installation and connections. Refer to Section 4 - INSTALLATION.

6-3 Throttle Dock Settings (Engines Stopped)

6-3.1 E2 - Throttle Minimum and E3 - Throttle Maximum Signal

ADJUSTMENTS MAY NOT BE REQUIRED.



Verify the existing Throttle Minimum and Maximum values, prior to adjusting them.



NOTE: Synchronization is dependent on the Throttle Minimum and Maximum adjustments being equal on each Processor.



NOTE: Prior to adjustments, the correct Engine Signal Selection should have been made during Section 5 - SET UP PROCEDURES.

Throttle Minimum (E2)

This function allows the installer the ability to adjust the Processor's Throttle signal at Idle, above and beyond the profile set in **E0** Engine Throttle Profile. This value is adjustable anywhere between 1% to 97% of the maximum throttle output capability of the driver. The value must be at least 3% less than **E3** Throttle Maximum setting.

Throttle Maximum (E3)





This function allows the installer the ability to adjust the Processor's Throttle signal at full throttle, above and beyond the profile set in **E0** Engine Throttle Profile. This value is adjustable anywhere between 4% to 100% of the maximum throttle output capability of the driver. The value must be at least 3% greater than the **E2** Throttle Minimum setting.

6-3.1.1 Processor Throttle Signal Check

Use the Service Field Test Unit and a Multimeter:

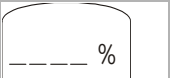
- A) Disconnect the Throttle Wire Harness from the Processor.
- B) Connect the 8-Pin connector of the Service Field Test Unit to the Processor Throttle connector and to the Throttle Wire Harness. Refer to Appendix B - MM13927 Service Field Test Unit manual.
- C) Depending on the type of signal required, follow the appropriate column of Table 16:

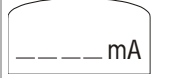
Table 16: Throttle Output Adjustments

PWM (Duty Cycle)	VOLTAGE (VDC)	Current (mA)	Frequency (Hz)
1. Set Multimeter to Duty Cycle Setting. 	1. Set Multimeter to Voltage Setting 	1. Set the Multimeter up as an Amp Meter 	1. Set Multimeter to Frequency setting. 
2. On the Multimeter attach the black Lead to COM and the red Lead to V.	2. On the Multimeter attach the black Lead to COM and the red Lead to V.	2. On the Multimeter attach the black Lead to COM and the red Lead to mA.	2. On the Multimeter attach the black Lead to COM and the red Lead to V.
3. Attach the Multimeter black Lead to the negative (-) and the red LED to the PWM.	3. Attach the Multimeter black Lead to the negative (-) and the red LED to the VDC.	3. Attach the Multimeter black Lead to the negative (-) and the red LED to the mA	3. Attach the Multimeter black Lead to the negative (-) and the red LED to the Frequency.

- D) Turn ON power to the Engine's ECM. Ensure power is ON to the Processor.
- E) Scroll to Function Code to be checked (**E2** or **E3**). The Multimeter will read the output signal for Throttle Minimum (**E2**) or Throttle Maximum (**E3**).



NOTE: To read Current, the mA Push Button on the Service Field Test Unit MUST be depressed.



NOTE: Synchronization is dependent on the Throttle Minimum and Maximum adjustments being equal on each Processor.



6-3.1.2 Throttle Adjustment

If **E2** Throttle Minimum or **E3** Throttle Maximum require adjustment, perform the following on the appropriate Processor.

To change the Value (Refer to Sections 5-2 and 5-3, page 5-2):



NOTE: When in Set Up Mode to show values that have more than two digits (EXAMPLE: 010.5) DEPRESS AND HOLD the RIGHT ARROW. The Function Code will disappear and be replaced with the three or four digit Value. The Decimal Indicator will light if the number has a decimal value. Releasing the RIGHT ARROW returns the Display to the Normal blinking Function Code and two digit value.

Figure 35: Display LED Function E2



- A) Leave the Service Field Test Unit connected to the Processor.
- B) Activate Set Up Mode.
- C) Scroll either Up or Down to change the value of the parameter to be changed. (**E2** Throttle Minimum, **E3** Throttle Maximum)

Figure 36: Display LED Function E3



- D) Store the Value to memory.
- E) Remove the Service Field Test Unit and reconnect the Throttle Wire Harness to the Processor.

6-4 E4 - Throttle Maximum Astern(Engines Stopped)

This value determines the percentage of Throttle Maximum that is allowed in Astern. This is adjustable anywhere between 1% to 100%.

The values of this Function are **1.0%** to **100.0%**. Throttle defaults are based on Throttle Profile selected.

- A) Disconnect the Throttle Wire Harness from the CruiseCommand Processor.
- B) Connect the 8-Pin connector of the Service Field Test Unit to the Processor **THROTTLE** connector and to the Throttle Wire Harness. Refer to Appendix B - MM13927 Service Field Test Unit manual.
- C) Turn ON power to the Engine's ECM. Ensure Power is ON to the Processor.
- D) Scroll to Function Code **E4**.

- The Multimeter will read the output signal for Throttle Maximum Astern.



NOTE: To read current, the mA Push Button on the Service Field Test Unit must be depressed.

Figure 37: Display LED Function E4



- E) Activate Set Up Mode.
- F) Scroll Up or Down to the desired Value.
- G) Store the Value to memory.

- H) Remove the Service Field Test Unit and reconnect the Throttle Wire Harness to the Processor.

6-5 Engine Stop Switches (Engines Running)

Start the engine(s) and verify that the Stop switches (normally push buttons) function correctly at all Remote Stations. Refer to the information supplied by the engine manufacturer or switch supplier for set up and adjustments.



CAUTION: An Engine Stop Switch at each station is an absolute requirement. Refer to CFR46, 62.35-5 and ABYC P-24.5.8.



WARNING: Do not attempt to continue tests until all Engine Stop Switches are functioning correctly!

6-6 Control Head Command Checks (Engines Running)

- A) Start the engine(s) and let them run at Neutral/Idle.
- B) Place one Control Head lever at a time into the Ahead detent, the Astern detent and then Neutral.
 - SOLENOID SHIFT: Confirm that the movement of the vessel is in the correct direction. If incorrect, reverse the electric cable connections at the shift solenoids.
- C) Place the Control System into Warm-Up Mode and confirm that there is control of speed.
- D) Run the throttle up to approximately 20% of the throttle range for at least 10 seconds.
- E) Return the lever to the Neutral/Idle position.
- F) Repeat steps A) thru E) at the remaining Control Head levers.

6-7 E1 - Throttle in Neutral (Cummins-Quantum Engines Only) (Engines Running)



NOTE: This Function is used ONLY when the E0 Select Engine Throttle Profile is set for 03 - Cummins Quantum.

The **Cummins-Quantum Engine** requires different throttle command signals in Neutral than when In-Gear. These engines require a voltage throttle signal of 0.9 VDC when unloaded at Neutral. When a load is placed upon the engine by engaging the clutch, the throttle command signal increases to 1.2 VDC.

The Throttle in Neutral Function allows the installer the ability to adjust the throttle signal level at Neutral/Idle and also adjust a second throttle signal level for when the clutch is engaged. The Neutral value may be adjusted anywhere between 1 to 20% of the maximum throttle output capability of the voltage circuit. **For example**; if the circuit has the ability to drive 0 to 5.00 VDC and the value entered is 10, the output at Neutral would be 0.50 VDC.

The values of this Function are **01.0%** to **50.0%**. Throttle defaults are based on the Throttle Profile selected.

- A) Disconnect the Throttle Wire Harness from the Processor.
- B) Connect the 8-Pin connector of the Service Field Test Unit to the Processor THROTTLE connector and to the Throttle Wire Harness. Refer to Appendix B -MM13927 Service Field Test Unit manual.
- C) Turn ON power to the Engine's ECM. Ensure Power is ON to the Processor.
- D) Scroll to Function Code **E1**.
- E) Activate Set Up Mode.
- F) Scroll Up or Down to the desired Value.
- G) Store the Value to memory.

Figure 38: Display LED Function E1

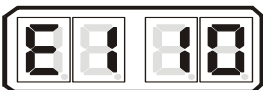

- H) Remove the Service Field Test Unit and reconnect the Throttle Wire Harness to the Processor



6-8 E5 - Throttle Pause Following Shift (Engines Running)



NOTE: A Test Control Head and a stop-watch are recommended to determine the correct setting for the Throttle Pause. If a Test Control Head is not available, a second person may be needed.

- A) Move the Station in command's lever to the Ahead detent, while monitoring the Shaft.
 - ELECTRIC THROTTLE: Start the stop-watch while monitoring the Shaft.
- B) When the Shaft begins to rotate, stop the stop-watch.
- C) Record the time expired on the stop-watch.



NOTE: If the time recorded in step C) exceeds 5.0 seconds, a Clutch Pressure Interlock is required. Refer to Section 8 - CONTROL OPTIONS.

To change the Value (Refer to Sections 5-2 and 5-3, page 5-2):

Figure 39: Display LED Function E5



- A) Scroll to Function Code **E5**.
- B) Activate Set Up Mode.
- C) Scroll Up or Down to the desired Value.
- D) Store the Value to memory.

6-9 E6 - High Idle (Engines Running)

This function allows the operator the option of having a second elevated Idle speed. This second elevated Idle can be adjusted from **0** to **20%** of full throttle. If **0** is selected, High Idle will be the same as normal or Low Idle, which is the default value.

When power is first applied to the system, the commanded throttle is low. In order to increase the RPM to the High Idle command, the Transfer Button must be depressed for 1/2 second then released. This can be done with the Control Head lever in either the Ahead, Neutral, or Astern Detent.

The values of this Function are **0%** to **20%** of Throttle Maximum. Default Value is set to **00**.

- A) Disconnect the Throttle Wire Harness from the Processor.
- B) Connect the 8-Pin connector of the Service Field Test Unit to the Processor Throttle connector and to the Throttle Wire Harness. Refer to Appendix B - MM13927 Service Field Test Unit manual.
- C) Turn ON power to the Engine's ECM. Ensure Power is ON to the Processor.
- D) Scroll to Function Code **E6**.
 - The Multimeter will read the output signal for Idle.



NOTE: To read current, the mA Push Button on the Service Field Test Unit must be depressed.

Figure 40: Display LED Function E6

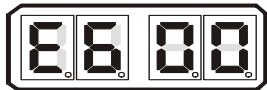

- E) Activate Set Up Mode.
- F) Scroll Up or Down to the desired Value.
- G) Store the Value to memory.

- H) Remove the Service Field Test Unit and reconnect the Throttle Wire Harness to the Processor.



6-10 L7 - Lock Up Percentage (Hurth Transmissions Only) (Engines Running)

This function controls the amount of current while the gear is locked up and troll is turned OFF. Refer to the Gear Manual for maximum current setting

Factory calculated preset values are set if **L106** or **L107** are used.

Function Range: **0.0 - 100.0%**

Preset Values: **L106** (12 VDC) **45.0**

L107 (24 VDC) **60.0**

If the preset values need to be altered, a multimeter must be set to measure the current. Refer to Appendix B - MM13927 Service Field Test Unit manual on set up.

To change the Value (Refer to Sections 5-2 and 5-3, page 5-2):

Figure 41: Display LED Function L7 A) Scroll to Function Code **L7**.

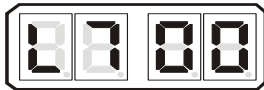

- B) Activate Set Up Mode.
- C) Scroll Up or Down to the desired Value.
- D) Store the Value to memory
- E) Remove the Service Field Test Unit and multimeter, replacing any unplugged wire harnesses.



7 SEA TRIALS



WARNING: It is imperative that the information provided in the previous Sections has been read and followed precisely, prior to attempting a Sea Trial. If any of the following tests fail, discontinue the Sea Trial immediately and return to the dock. Consult Appendix B Troubleshooting Section or a ZF Facility prior to resuming the Sea Trial.



NOTE: In Multi Screw Applications, the following tests must be performed on all engines/transmissions. During the course of the Dock Trial and Sea Trials, fill out the Trial Report at the end of Section 7. Retain this information for future use.

7-1 Full Speed Setting

- A) Warm-up the engine(s) and transmission(s) and slowly move into open water.
- B) Gradually move the Control Head lever(s) to Full speed.
- C) If synchronization is installed, disable synchronization as explained in Section 2 - OPERATION.
 - ELECTRIC THROTTLE: If the engine RPM is low, refer to Appendix B - Service Field Test Unit on how to check electric setting.
 - If the engine RPM is high, decrease by using Function Code **E3** - Throttle Maximum, as explained in Section 6 - DOCK TRIALS.
- D) For multi screw applications, check that matching Idle, Mid-range and Full speed Control Head lever positions cause equal RPM in both engines.
 - ELECTRIC THROTTLE: If RPM's do not match, adjust Function Code **E3** - Throttle Maximum, refer to Section 6 - DOCK TRIALS.

7-2 C2 - Proportional (Reversal) Pause

The proportional pause feature provides engine deceleration when making a direction change. The pause is variable and in proportion to:

- The Control Head's lever position prior to the reversal.
- How long the Control Head's lever has been in that position prior to the reversal.

The **C4** - Proportional (Reversal) Pause Ratio for the **C2** Function is stored during Set Up. Refer to Section 5 - SET UP PROCEDURES.

The sequence of events, are as follows for the different Reversal Pause types:

7-2.1 In-Gear Delay [C200]

- 1 The Throttle position drops to Idle.
- 2 The Transmission remains engaged in Ahead or Astern.
- 3 The Control System pauses at this position until the delay has timed out.
- 4 The Transmission shifts to the opposite gear (Astern or Ahead).
- 5 The Throttle position moves to the Control Head's present lever position.

7-2.2 Neutral Delay [C201]

- 1 The Throttle position drops to Idle.
- 2 The Transmission shifts to Neutral.
- 3 The Control System pauses at this position until the delay has timed out.
- 4 The Transmission shifts to the opposite gear (Astern or Ahead).
- 5 The Throttle position moves to the Control Head's present lever position.



7-2.3 Store C2 - Proportional Pause Value

To change the Value (Refer to Sections 5-2 and 5-3, page 5-2):

Figure 42: Display LED Function C2

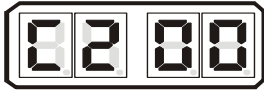

- A) Scroll to Function Code C2.
- B) Activate Set Up Mode.
- C) Scroll Up or Down to the desired Value.
- D) Store the Value to memory.

7-3 C3 - Proportional (Reversal) Pause Time



NOTE: The pause on a through Neutral shift is proportional to the speed commanded and the time at that speed. The Values listed for Function Code C3 - Proportional (Reversal) Pause Time, are the maximum possible delays. When shifting from Idle Ahead to Idle Astern or vice-versa the delay is zero. The time required to build up to the maximum pause is six times the Value selected. In addition, in order to build up to the maximum delay Value, the System must be commanding Full Throttle. The Pause when shifting from Astern to Ahead is either half or the same as the Ahead to Astern delay depending on the Value selected for Function Code C4 - Proportional (Reversal) Pause Ratio.

7-3.1 Determine C3 Pause Requirement



NOTE: A stop-watch is required to accurately program the Proportional (Reversal) Pause Time.

The amount of pause required is determined as follows:

- A) Place the Control Head lever(s) to the Full Ahead position.
- B) Leave the Control Head lever(s) at this position for whichever of the following two is longer:
 - Sixty seconds.
 - The vessel's speed through the water reaches maximum.
- C) Quickly move the Control Head lever(s) to Ahead Idle or Neutral, (depending on Function Code C4 setting) while starting the stop-watch.
- D) When the engine(s) RPM reaches Idle and the vessel's speed through the water is within two knots of the standard Idle Ahead speed, stop the stop-watch.
- E) Program Function Code C3 to the time expired on the stop-watch.

7-3.2 Program Function Code C3

The available Values are 00 to 99 seconds. The default Value is 03 seconds.

To change the Value (Refer to Sections 5-2 and 5-3, page 5-2):

Figure 43: Display LED Function C3

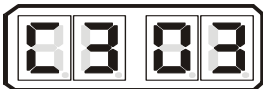

- A) Scroll to Function Code C3.
- B) Activate Set Up Mode.
- C) Scroll Up or Down to the desired Value.
- D) Store the Value to memory.

7-3.3 Testing Proportional (Reversal) Pause Time



CAUTION: It is critical that the Proportional (Reversal) Pause is tested as outlined below, to ensure that it is properly programmed. Failure to do so could cause damage to the transmission.

- A) Position the boat in open water and slowly increase the Throttle to 25% of the speed range.



- B) Leave the Control Head lever(s) at this position for at least 60 seconds.
- C) Quickly move the Control Head lever(s) to Idle Astern.
 - The engine(s) RPM should drop to Idle.
 - The Clutch should stay engaged or shift to Neutral for 25% of the time selected with Function Code **C3** Proportional Pause Time.
 - Once the time has expired, the Clutch should Shift to Astern.
 - The engine RPM will drop slightly when the Astern load is placed on the engine, but not to the point where it comes close to stalling.
- D) Increase the Throttle slightly until the vessel starts moving in the opposite direction.
 - If the engine stalled or came very close to stalling, increase the Value of Function Code **C3** by following the steps in the previous Section. Repeat steps A) through C).
 - If the engine does not stall or come close to stalling, proceed with the next step.
- E) Repeat steps A) through D) with the Throttle at 50%, 75%, and 100% of the speed range.
 - If the engine stalls at any time, increase the Value of Function Code **C3** by one (1) second and repeat the steps A) through D) again.
- F) Once a Full Speed Reversal is successful without coming close to stalling, the Proportional Pause is properly adjusted.

7-4 Synchronization Test

7-4.1 Equal Throttle Synchronization

- A) Move both Control Head levers side by side to approximately 25% of the Throttle range.
- B) If previously disabled, enable the synchronization by depressing the transfer button for two seconds.
 - The green LED on the Control Head should illuminate, indicating synchronization.
- C) Check the engine tachometers to see if they are within 1% of one another.
- D) Move both Control Head levers side by side to approximately 50% of the Throttle range.
- E) Check the engine tachometers to see if they are within 1% of one another.
- F) Move both Control Head levers side by side to approximately 75% of the Throttle range.
- G) Check the engine tachometers to see if they are within 1% of one another.
- H) Move both Control Head levers side by side to 100% of the Throttle range.
- I) Check the engine tachometers to see if they are within 1% of one another.
 - While synchronized, if the tachometers have a greater than 1% difference at any engine RPM, Active Synchronization is recommended.

7-4.2 Active Synchronization

- A) Move both Control Head levers side by side to approximately 25% of the Throttle range.
- B) If previously disabled, enable the synchronization by depressing the transfer button for two seconds.
 - The green LED on the Control Head may blink while driving toward synchronization.
 - Once the engine RPM's are within 1% of one another, the green LED will remain solidly lit.
- C) Check the engine tachometers to see if they are within 1% of one another.
- D) Move both Control Head levers side by side to approximately 50% of the Throttle range.
- E) Check the engine tachometers to see if they are within 1% of one another.
- F) Move both Control Head levers side by side to approximately 75% of the Throttle range.



- G) Check the engine tachometers to see if they are within 1% of one another.
- H) Move both Control Head levers side by side to 100% of the Throttle range.
- I) Check the engine tachometers to see if they are within 1% of one another.

While synchronized, if the tachometers have a greater than 1% percent difference at any engine RPM, or if they appear to be continually "hunting" for the correct RPM, refer to the Appendix B Troubleshooting Section.

7-5 L2 - Trolling Minimum and L3 - Trolling Maximum Adjustments

Troll Minimum Pressure (L2)

The amount of current delivered to the Proportional Valve when Minimum Pressure is desired, is set with this function. This is adjustable anywhere between **01.0%** to **99.0%** of the total current output capability of the circuit. The value set must be at least 1% less or more (depending on whether non-inverted or inverted is selected) than Troll Maximum. The **Default Value** is **10.0%**.

Troll Maximum Pressure (L3)

The amount of current delivered to the Proportional Valve when Maximum Pressure is desired, is set with this function. This is adjustable anywhere between 02.0% to 100.0% of the total current output capability of the circuit. The value set must be at least 1% more or less (depending on whether non-inverted or inverted is selected) than Troll Minimum. The **Default Value** is **25.0%**.

When the transmission has reached operating temperature, measure and record in Table 16: the Propeller Shaft RPM at Idle Ahead.

Table 16: Record Propeller Shaft RPM at Idle Ahead

Propeller Shaft RPM (when engines have reached operating temperature)

Use the Field Service Test Unit and a Multimeter: (Reference Appendix B - MM13927 Service Field Test Unit manual for set up.)

- A) Disconnect the Clutch/Troll Wire Harness from the Processor.
- B) Connect the 12-Pin connector of the Service Field Test Unit to the Processor Clutch connector and to the Clutch/Troll Wire Harness.
- C) Set Multimeter to Current (mA) setting.
- D) On the Multimeter, attach the Black Lead to COM and the Red Lead to mA.
- E) Turn ON power to the Clutch Power Supply. Ensure Power is ON to the Processor.
- F) Position the Control Head lever to the Ahead Detent and turn Troll Mode ON.
- G) Activate the **Function Menu**.

7-5.1 L2 - Troll Minimum Set Up

Figure 44: Display LED Function L2

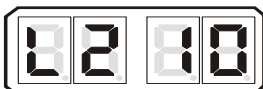

- A) Scroll to the Function Code.
 - The Multimeter will read the output signal for Troll Minimum when the Troll Command Switch on the Test Unit is flipped away from "Troll Command".
- B) Activate Set Up Mode.



C) Scroll Up or Down to the appropriate Value.



NOTE: When the trolling valve is in the minimum oil pressure position, Propeller Shaft RPM should be 30% of the engaged RPM noted in Table 16:.

D) Record Propeller Shaft RPM on Table 17:

Table 17: Record L2 - Minimum Trolling Pressure

SINGLE SCREW		
Propeller Shaft RPM at minimum Trolling Pressure (Approx. 30 - 50% of Table 16:)		
Shaft RPM	Current (mA)	Function %
TWIN SCREW		
Propeller Shaft RPM at minimum Trolling Pressure (Approx. 30 - 50% of Table 16:)		
Shaft RPM	Current (mA)	Function %
PORT		
STARBOARD		

E) Store the Value to memory

7-5.1.1 L3 - Troll Maximum Set Up

A) Position the Control Head lever through the selected Troll Lever Range to the Troll Maximum position.

Figure 45: Display LED Function L2

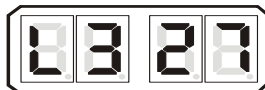

B) Scroll to the Function Code.

- The Multimeter will read the output signal for Troll Maximum when the Troll Command Switch on the Test Unit is flipped away from "Troll Command".



NOTE: It is difficult to use a slipping clutch to control shaft RPM between 70% and 100% of normal shaft RPM. However, it may be desirable to set the Maximum Trolling Pressure position higher than the 70% RPM, so that added oil pressure is available when maneuvering.

C) Activate Set Up Mode.

D) Scroll Up or Down to the appropriate Value.

E) Record Propeller Shaft RPM on Table 18:

Table 18: Record L3-Maximum Trolling Pressure

SINGLE SCREW		
Propeller Shaft RPM at maximum Trolling Pressure (Approx. 70% of Table 16:)		
Shaft RPM	Current (mA)	Function %
TWIN SCREW		
Propeller Shaft RPM at maximum Trolling Pressure (Approx. 70% of Table 16:)		
Shaft RPM	Current (mA)	Function %
PORT		
STARBOARD		

F) Store the Value to memory

G) Position the Control Head lever into the Neutral/Idle position.

H) Remove the Service Field Test Unit and reconnect the Clutch/Troll Wire Harness to the Processor.



7-6 L4 - Troll Throttle Limit



CAUTION: Consult the Trolling Valve's Installation Manual prior to programming any increased throttle above Idle, while slipping the Clutch. Failure to adhere to the Transmission manufactures directives may permanently damage the Clutch Pack and void the warranty.

- The Value programmed for Function Code L4 is a percentage of the throttle range. The Throttle Range is the difference between Throttle Maximum (E3) and Throttle Minimum (E2).
- The maximum percentage of the Throttle Range which the Value can be set to is **20%** of Full Throttle.
- The adjustment of this Function Code is a matter of personal preference. There is no set procedure which determines when increased throttle should be used and what percentage of the range it should be set to, but never exceed transmission manufacturers recommendation.
- The values of this Function are **00%** to **20%** of Throttle Maximum. Default Value is set to **00**.
 - A) Disconnect the Throttle Wire Harness from the Processor.
 - B) Connect the 8-Pin connector of the Service Field Test Unit to the Processor Throttle connector and to the Throttle Wire Harness. Refer to Appendix B - MM13927 Service Field Test Unit manual for set up.)
 - C) Turn ON power to the Engine's ECM. Ensure Power is ON to the Processor.
 - D) Activate the Function Menu.
 - E) Scroll to the Function Code.
 - The Multimeter will read the Troll Throttle Limit output signal.

Figure 46: Display LED Function L4



NOTE: To read current, the mA Push Button on the Service Field Test Unit must be depressed.

- F) Activate Set Up Mode.
- G) Change the Value of the Function.
- H) When the value required is displayed, store the value.
- I) Remove the Service Field Test Unit and reconnect the Throttle Wire Harness to the Processor.

7-7 L5 - Troll Pulse Duration

This function sets the time in seconds that the Proportional Valve will command L6 - Troll Pulse Percentage. This function gives a pressure boost to the Clutch plate in order to get the Propeller Shaft rotating prior to dropping to the level programmed in L2 - Troll Minimum.

The values of this Function are **0.0** to **9.9** Seconds. **Default Value** is set at **0.6** seconds.

To change the Value (Refer to Sections 5-2 and 5-3, page 5-2):

Figure 47: Display LED Function L5

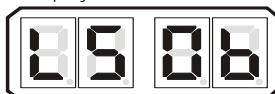

- A) Activate the Function Menu.
- B) Scroll to the Function Code.
- C) Activate Set Up Mode.
- D) Change the Value of the Function.
- E) When the value required is displayed, store the value.



7-8 L6 - Troll Pulse Percentage

This function sets the percentage of L3 - Troll Maximum that the Proportional Valve will be commanded when first entering Troll Mode. This function determines the amount of pressure boost to the Clutch plate in order to get the Propeller Shaft rotating prior to dropping to the level programmed in L2 - Troll Minimum.

The values of this Function are 0.0% to 100.0%. Default Value is set at 25%.

To change the Value (Refer to Sections 5-2 and 5-3, page 5-2):

Figure 48: Display LED Function L6



- A) Activate the Function Menu.
- B) Scroll to the Function Code.
- C) Activate Set Up Mode.
- D) Change the Value of the Function.
- E) When the value required is displayed, store the value.

7-9 Sea Trial Report

The purpose of this Sea Trial Report is to provide a convenient checklist and record of installation, dock trial set up, and sea trial performance of the ZF Marine Electronics Propulsion Control System. Please enter ALL of the information. We recommend that this form remains aboard the vessel, and a copy is sent to ZF Marine Electronics along with the Warranty Registration which is located at the end of this manual.

Table 19: Vessel Information

Vessel Name:		Hull #	Trial Date:	
Vessel Type:		Dwg No.:		
Installing Yard/Project Manager:		Tel:		
Owner/Owner's Representative:		Tel:		
ENGINE DATA:	MAKE:	MODEL:	HP(KW):	
			RPM:	
PROPELLER DATA:	No. of Screws:	Propeller Type:	Fixed	
			Other	
GEAR DATA:	MAKE:	MODEL:	RATIO:	
NO. OF REMOTE STATIONS:	Locations:			

7-9.1 Control System Checks

Make the following checks prior to applying power to the Processor.

Table 20: Processor

	PORT		STARBOARD	
Processor Serial Number:				
Is the Processor subject to excessive heat? (Above 70 degrees C)	YES	NO	YES	NO
At least 4 feet (1,2m) from strong magnetic fields?	YES	NO	YES	NO
Accessible for checkout, adjustments, and maintenance?	YES	NO	YES	NO



Table 20: Processor

Processor Serial Number:	PORT		STARBOARD	
	YES	NO	YES	NO
Are the Processors grounded?	YES	NO	YES	NO
Are all Electric Cables supported every 18 inches (45,72cm)	YES	NO	YES	NO
Are the electrical cable connections tight at the Processors and Control Heads?	YES	NO	YES	NO
Is the Processor's Start Interlock Circuit being used? If NO, what type of start interlock is being utilized?	YES	NO	YES	NO
Is there an Engine Stop Switch installed at each Remote Station	YES	NO	YES	NO
Are the Clutch cables protected by 10 Ampere Circuit Breakers?	YES	NO	YES	NO
Does Shift operate in the correct direction?	YES	NO	YES	NO
Does Throttle operate in the correct direction?	YES	NO	YES	NO

Table 21: Harness/Cable Lengths

Processor Serial Number:	PORT:		STARBOARD:	
	Length in Feet		Length in Feet	
Control Head (circle one) Harness Cable Sta # _____				
(circle one) Harness Cable Sta # _____				
(circle one) Harness Cable Sta # _____				
(circle one) Harness Cable Sta # _____				
(circle one) Harness Cable Sta # _____				
Ahead Solenoid Power Harness				
Astern Solenoid Power Harness				
If used, Neutral Solenoid Power Harness				
Clutch Power Harness				
If used, Clutch Pressure Switch Harness				
If used, External Alarm Circuit Harness				
Throttle Harness				
If used, Troll ON/OFF Harness				
If used, Troll Proportional Solenoid Harness				
If used, Serial Communication Harness				
If used, Tachometer Sensor Harness				

Table 22: Power Supply

Processor Serial Number:	PORT		STARBOARD	
	YES	NO	YES	NO
What is the source of Processor power and how is it charged?				
Is there a backup power supply? APS or other, explain	YES	NO	YES	NO
Are the power cables protected by 10 Ampere Circuit Breakers?	YES	NO	YES	NO
If separate power supplies are used for each Processor, do they have a common ground?	YES	NO	YES	NO
What is the Voltage when not being charged?	Battery _____ VDC		Battery _____ VDC	
	Processor _____ VDC		Processor _____ VDC	



Table 22: Power Supply

Processor Serial Number:	PORT	STARBOARD
	What is the Voltage when connected to Shore Power?	Battery _____ VDC
	Processor _____ VDC	Processor _____ VDC
What is the Voltage when the engines are running?	Battery _____ VDC	Battery _____ VDC
	Processor _____ VDC	Processor _____ VDC

Table 23: Dock Trials

Processor Serial Number:	PORT:		STARBOARD:	
	Does the engine start when the Control System is turned OFF?	YES	NO	YES
Does the Engine Stop Switch function at all Stations, regardless of RPM?	YES	NO	YES	NO
Can all Remote Stations take command?	YES	NO	YES	NO
Does the Warm-up Indicator Light blink in Ahead?	YES	NO	YES	NO
What is the Low Idle RPM?	RPM		RPM	
High Idle RPM (optional)	RPM		RPM	
Does the vessel surge forward with Control Head lever in the Ahead Detent?	YES	NO	YES	NO

Table 24: Record at Dock (Requires use of Field Service Test Unit)

Processor Serial Number:	PORT:	STARBOARD:
	Throttle in Neutral (Cummins Quantum only)	VDC, mA, Hz, or %
Throttle Minimum	VDC, mA, Hz, or %	
Throttle Maximum	VDC, mA, Hz, or %	
Troll Minimum (signal)	mA	
Troll Maximum (signal)	mA	

Table 25: Sea Trials

Processor Serial Number:	PORT:		STARBOARD:	
	Do the Dual Control Head levers match position and RPM throughout the speed range?	YES	NO	YES
The Full Speed Reversal Delay is set for how many seconds?	SECONDS		SECONDS	
Is Synchronization operational?	YES	NO	YES	NO

Table 26: Record during Sea Trials (Requires use of Field Service Test Unit)

Processor Serial Number:	PORT:	STARBOARD:
	Engine Idle RPM	RPM
Shaft Idle RPM (Calculate the Shaft Idle RPM as follows: Engine Idle RPM/Gear Ratio)	RPM	
Full Throttle RPM	RPM	
Troll Minimum (Shaft RPM) (The desired Troll Minimum can be calculated as follows: Shaft Idle RPM x 0.3)	RPM (Actual)	
Troll Maximum (Shaft RPM) (The desired Troll Maximum can be calculated as follows: Shaft Idle RPM x 0.7)	RPM (Actual)	



7-9.2 Record Parameters

Record information onto the following Tables only after ALL information has been recorded in the previous Section **Control Checks**.

Table 27: Record Processor Functions

CODE:	FUNCTION NAME:	PORT:	STBD:
A0	Processor Identification		
A1	Number of Engines		
A2	One Lever Operation		
A3	Station Expander (SE)	Leave At Default. If Used, Contact A ZF Marine Electronics Representative	
A4	Neutral Indication Tone		

Table 28: Record Throttle Functions

CODE:	FUNCTION NAME:	PORT:	STBD:
E0	Engine Throttle Profile		
E1	Throttle in Neutral (only available with Type 3 Throttle Profile)		
E2	Throttle Minimum		
E3	Throttle Maximum		
E4	Throttle Maximum Astern		
E5	Throttle Pause Following Shift		
E6	High Idle		
E7	Active Synchronization		

Table 29: Record Clutch Functions

CODE:	FUNCTION NAME:	PORT:	STBD:
C0	Clutch Pressure Interlock		
C1	Clutch Interlock Delay		
C2	Proportional (Reversal) Pause		
C3	Proportional (Reversal) Pause Time		
C4	Proportional (Reversal) Pause Ratio		

Table 30: Record Troll Functions

CODE:	FUNCTION NAME:	PORT:	STBD:
L0	Troll Enable / Control Head Troll Lever Range		
L1	Troll Valve Function		
L2	Troll Minimum Pressure		
L3	Troll Maximum Pressure		
L4	Troll Throttle Limit		
L5	Troll Pulse Duration		
L6	Troll Pulse Percentage		
L7	Lock Up percentage (Hurth Only) Only use when L106 or L107 is selected.		



Table 31: Troubleshooting Functions

CODE:	FUNCTION NAME:	PORT:	STBD:
H2	High Side Driver Fault Detection Enable		

7-9.3 Comments (Please use additional paper as necessary):

7-9.3.1 General Installation Condition

7-9.3.2 Any Irregularities:

Is the Installation and Troubleshooting Manual on board?

Is a copy of this completed Report placed in the Installation and Troubleshooting Manual on board?

INSPECTOR _____ DATE _____

MAIL A COMPLETED COPY TO:

ZF MARINE ELECTRONICS, LLC. 12125 HARBOUR REACH DRIVE, STE B MUKILTEO, WA 98275

OR FAX TO: SERVICE DEPARTMENT 425-493-1569



8 CONTROL OPTIONS

8-1 External Alarm Capability



CAUTION: The Processor's Alarm circuit is limited to a maximum current of 0.5 Amperes and a maximum voltage of 100 Volts DC. Exceeding these limits will permanently damage the Alarm circuit.



NOTE: The following information applies to CruiseCommand Processors with a Processor Serial Number of ZE01320 or HIGHER. If your Processor has a lower Serial Number and you will be using this option, contact ZF Marine Electronics for guidance.

The Alarm Output of the Processor can be used to connect to an external alarm system supplied by others. The use of this output by the customer is optional.

The Processor comes equipped with a normally OPEN relay contact for connection to an external Status Indication circuit. The relay energizes, CLOSING the contact when the Circuit Board has power applied and the software program is running normally. In the event of a power loss or the software program detects an anomaly, the relay de-energizes and the contact OPENS.

Figure 49: Example of Control System Status Indication

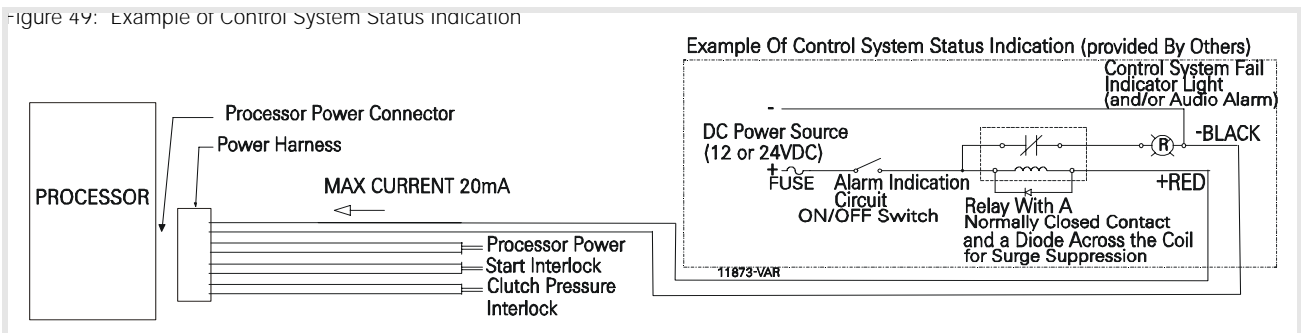
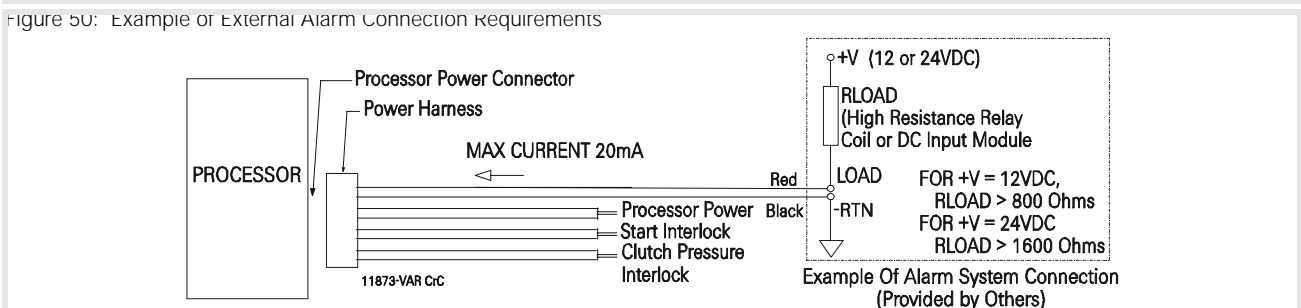

Figure 50: Example of External Alarm Connection Requirements



8-1.1 Installation

The following items should be considered when designing and installing the Status Indication Panel:

- A Power Wire Harness with Alarm Output must be used if an External Alarm is required.
 - The External Status Indication Circuit must not use the same power source as the Processor.
 - Since the External Status Indication Circuit is activated on a loss of power to the Processor, an On/Off Switch is strongly recommended.
 - Figure 49: and Figure 50: are an example of a suitable circuit, but not necessarily the only circuit configuration acceptable.
- A) Plug the Power Wire Harness into the Processor's Power connector.
 - B) Run the two-conductor Alarm cable to the location of the Status Indication Circuit.



- C) Connect the black and red conductors to the Status Indication Circuit as shown in Figure 49: and Figure 50:.

8-2 Auxiliary (Backup) Control System

The Auxiliary (Backup) System (referred to as BU System hereafter) provides a control system which is fully independent from the ZF Marine Electronics Control System. The BU System can control the gear as well as the engine, but it does not include ZF Marine Electronics control logic, safety interlock and timing circuits. In other words, there is no protection for operator errors, such as shifting into gear at elevated rpm's.

- Provides redundant throttle and clutch signals in the event of a failure of the Main Control System.
- May be selected at any time by the operator.
- A full explanation of the installation, operation and adjustment of the BU System is provided in the Installation Manual supplied with the BU System.

If this option is going to be used, please contact a ZF Marine Electronics Representative for further information.

8-3 Clutch Pressure Interlock



NOTE: The Clutch Pressure Interlock **C0** must be set to be used. Refer to the Section 5 - SET UP PROCEDURES for information on setting Function Code **C0**.

The Clutch Pressure Interlock uses a Pressure Switch which monitors the Ahead and Astern Clutch pressures to prevent high engine RPM when the clutch is not fully engaged.

The Pressure Switch must have a Normally Open (N.O.) contact that closes when adequate Clutch pressure is reached. The primary function of the Interlock is to prevent high engine RPM when the Clutch is not fully engaged. The Interlock option must be selected with Function Code **C0**. There are two selectable methods of operation as described below:

8-3.1 C0 - Clutch Pressure Interlock Methods of Operation

8-3.1.1 01 - Installed

When selected, the Interlock will command the Throttle to Idle, if low or a loss of pressure occurs while cruising. The Interlock is activated when the Pressure Switch's contact opens for the minimum period of time selected with Function Code **C1**.

If adequate Clutch pressure is not reached in the time programmed in Function Code **E5**, throttle will only be allowed to increase to this commanded speed for the time programmed in Function Code **C1** and then returned to Idle.

The Throttle will remain at Idle until the Control Head's lever is returned to Idle, the Pressure Switch contact closes and a speed command above Idle is commanded.

8-3.1.2 02 - Throttle Clutch Pressure Interlock

This option is typically selected when the Clutch takes longer than five seconds to reach full pressure. The Throttle will remain at Idle until there is a closure of the Pressure Switch's contact. This prevents speeds above Idle prior to full Clutch engagement.

In the event of a loss of Clutch pressure while cruising, the Throttle will be returned to Idle after the time selected with Function Code **C1** has expired. Once a closure of the Switch is



sensed, indicating adequate pressure, the Throttle immediately returns to the commanded signal, without having to return the Control Head lever to Idle first, as is the case with Value 01.

Figure 51: Clutch Pressure Switch with Processor Harness Diagram

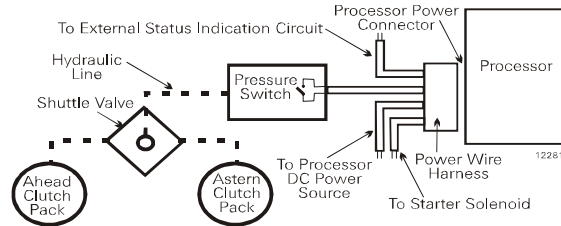

8-3.2 Installation

The installation of the Clutch Pressure Switch is the same for both methods of operation. (Refer to the above Figures.)

- A) Install a Shuttle Valve on or near the Transmission.
- B) Connect hydraulic line from the Ahead and Astern Clutches.
- C) Connect a hydraulic line that is no longer than 5 feet (1,524m) and at approximately the same height between the Shuttle Valve and the Pressure Switch.
- D) Connect the Power Wire Harness's Clutch Pressure Interlock cable to the Pressure Switch's normally open contact.
- E) Calibrate the Pressure Switch to close when adequate Clutch Pressure is reached. (Refer to the Transmission Manufacturers Installation Manual)

8-4 Station Expander (SE)

The Processor allows up to four Remote Stations. The SE allows up to an additional four Remote Stations for a total of eight Stations.

The SE and Processor communicate via the Serial Communication cable. Control Heads connected to the SE offer all of the functionality of a standard Remote Station.

For detailed information on the operation, installation and adjustment of the SE, refer to the Station Expander Installation Manual supplied with the Expander.

If this option is going to be used, please contact a ZF Marine Electronics Representative for further information.



9 PERIODIC CHECKS AND MAINTENANCE

The items listed below should be checked on an annual basis or less, when noted:

9-1 Control Heads

- Check the terminal strip for signs of corrosion or a loose connection.
- If used, disconnect the Deutsch connector and check the pins and sockets for signs of moisture and corrosion.

9-2 Processor

- Check all terminal connections for signs of corrosion or loose connections.
- Un-plug and inspect all Deutsch connectors for signs of moisture or corrosion.

APPENDIX A



400 Series Standard Control Head Variations

This Service Sheet reflects all current variations of the standard 3-detent
ZF Marine Electronics 400 Series Control Heads.

Part Numbering Configurations

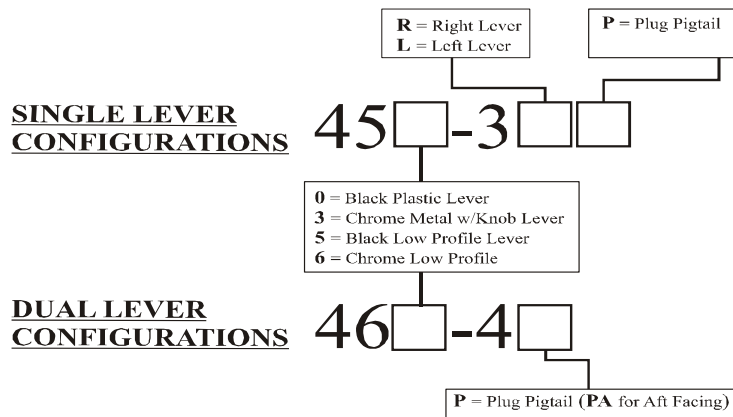

Detents Available

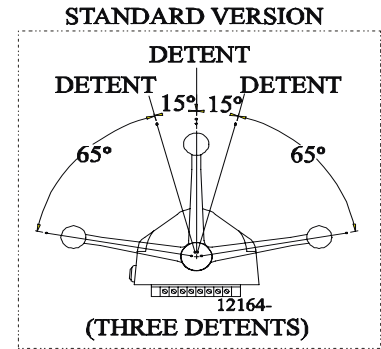

REQUIREMENTS:

MicroCommander/ClearCommand: one (1) 8-Conductor Cable per Control Head lever.

Pluggable MicroCommander/ClearCommand: one (1) Control Head Harness per Control Head lever.

CruiseCommand: one (1) Control Head Harness per Control Head lever.

Included with the Control Head:

- Gasket
- Mounting screws and washers
- Terminals (For 8-Conductor or 1-Connector Harnesses)
- Watertight cable grip for the cable entrance on the Processor (For 8-Conductor)

When the Control Head is properly mounted on a console, it is spray proof from the top only. An adhesive gasket must be used to seal it to the mounting surface. However, below the mounting surface it needs protection from water or spray. Consider using a Weather Mount Enclosure, which is available from ZF Marine Electronics.

MOUNTING AND INSTALLATION:

Select the desired mounting locations and make cutouts per template. Refer to the Dimensions Diagram.

Check that the four mounting screws will start into the Control Head. Remove the Control Head from the cutout.

Remove the backing from the adhesive gasket and apply the gasket adhesive side to the console around the cutout.

Run cable/harnesses between Processor and Control Head. Label both ends with Station it connects (EXAMPLE: Port, Center, or Starboard; Port Thrust, Port Throttle; etc.)

There are two types of Control Head connections available: Plug or Terminal Connected. Both types may be used with MicroCommander, ClearCommand, or CruiseCommand using the appropriate cable or harness. Follow the appropriate steps for the Control Head that has been supplied for your system.

Type 1 - Pluggable

Plug Control Head cable into the pigtail at the Control Head. (Ensure the correct Processor Cable is being plugged into the corresponding Control Head lever pigtail).

When connecting the plugs, ensure that the release button or buttons are depressed and held until plug is fully connected or disconnected. Connecting or disconnecting plugs without depressing and holding the release button or buttons will damage the plug.

Type 2 - Standard Cable

Strip back the PVC cover on the shielded cable approximately 2-1/2" (63,5mm) at the Control Head. At the Control Head end of the cable strip and cut off the shielding and drain wire flush with the end of the PVC cover (the drain wire at the Control Head is not connected to ground).

Strip 3/8" (9,5mm) insulation off each wire.

Twist the individual strands of the wires to minimize fraying.

Crimp a locking fork terminal (included with each Control Head) to each of the conductors.

Make connections to the Control Head as indicated in the following TERMINAL CONNECTIONS diagrams.

Dimensions

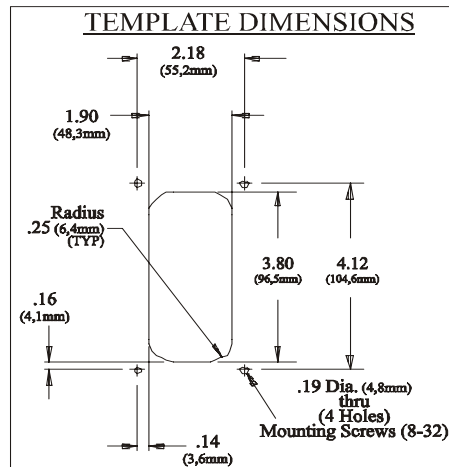
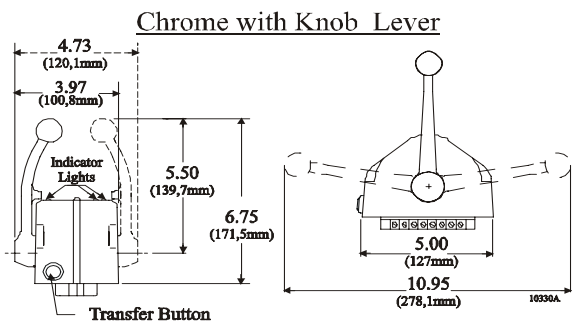
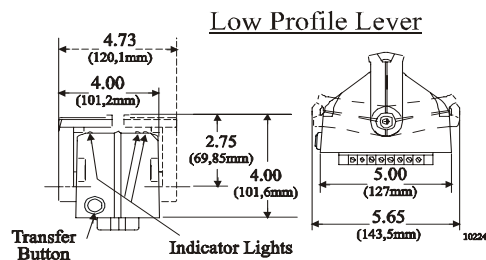
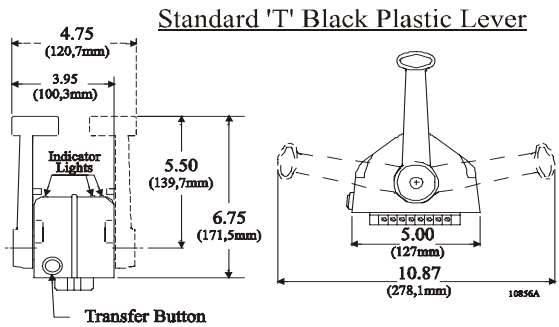

ALWAYS REFER TO THE MANUAL THAT IS SUPPLIED WITH THE CONTROL SYSTEM FOR ANY UNIQUE CONTROL HEAD CONNECTIONS FOR YOUR SYSTEM.

When cable connections are complete, MOUNT Control Head to the console using the four (4) mounting screws and washers supplied with the Control Head.

CABLE/HARNESS CONNECTIONS:

Dual Control Head Connections TERMINAL CONNECTIONS

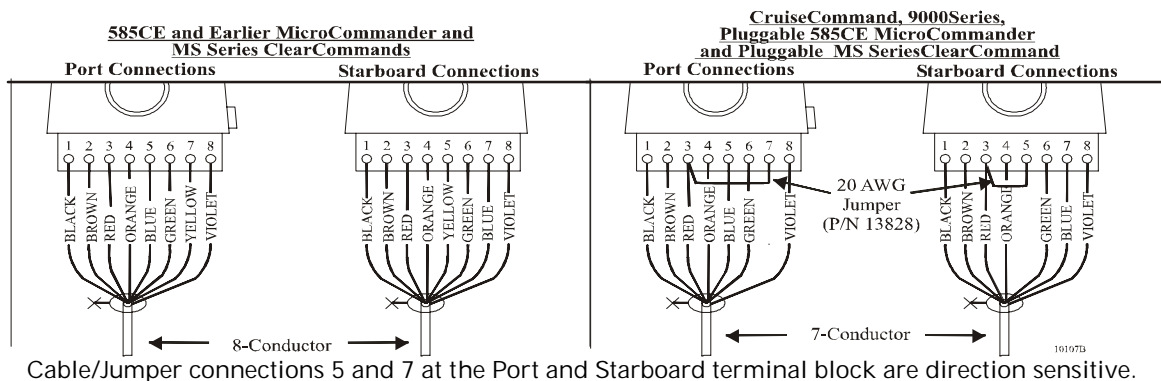

MicroCommander/ClearCommand

Port Lever:	Starboard Lever:
Terminal 3 Red	Terminal 3 Red
Terminal 5 Blue	Terminal 5 Yellow
Terminal 7 Yellow	Terminal 7 Blue

CruiseCommand/9000 Series

Port Lever:	Starboard Lever:
Terminal 3 Red & JUMPER	Terminal 3 Red & JUMPER
Terminal 5 Blue	Terminal 5 JUMPER
Terminal 7 JUMPER	Terminal 7 Blue

PLUGGABLE CONNECTIONS

Pluggable Control Heads are supplied with a harness pigtail for each lever. When disconnecting/connecting the plugs, ensure that the release button or buttons are depressed and held until plug is fully disconnected or

connected. Disconnecting/connecting plugs without depressing and holding the release button or buttons WILL damage the plug.

Aft Facing Control Heads

For dual lever Control Head Stations that have the user facing aft: Reverse connections 5 and 7.

For single lever Control Head Stations that have the user facing aft and the one Control Head lever on the user's right, reverse connections 5 and 7.

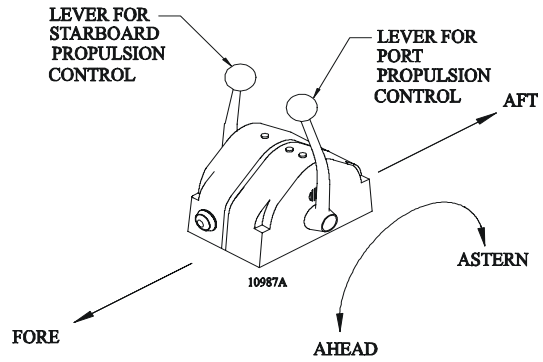

Handheld Control is a Station option. Contact your ZF Marine Electronics Dealer for further information on Handheld requirements and options.

0.19 Diameter (4,8mm) through Holes
(4 holes)





MC2000 Series Standard Control Head Variations

This Service Sheet reflects all current variations of the standard 3-detent ZF Marine Electronics MC2000 Series Control Heads

Part Numbering Configurations

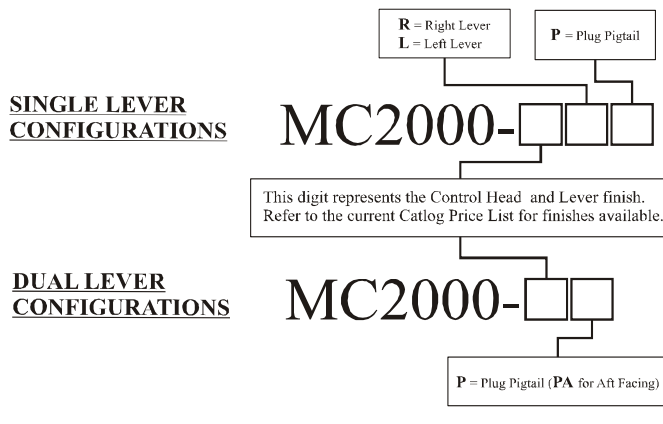

Detents Available

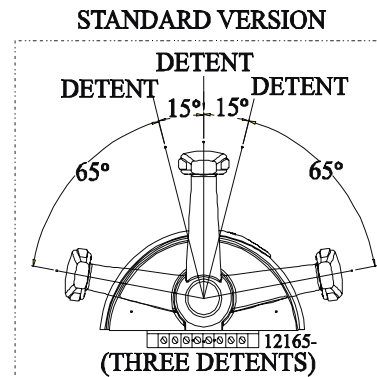

REQUIREMENTS:

MicroCommander/ClearCommand: one (1) 8-Conductor Cable per Control Head lever.

Pluggable MicroCommander/ClearCommand: one (1) Control Head Harness per Control Head lever.

CruiseCommand: one (1) Control Head Harness per Control Head lever.

Included with the Control Head:

- Mounting screws
- Terminals (For 8-Conductor or 1-Connector Harnesses)
- Watertight cable grip for the cable entrance on the Processor (For 8-Conductor)

When the Control Head is properly mounted on a console, it is spray proof from the top only. An adhesive gasket is mounted on the bottom of the Control Head to seal it to the mounting surface. However, below the mounting surface it needs protection from water or spray. Consider using a Weather Mount Enclosure, which is available from ZF Marine Electronics.

MOUNTING AND INSTALLATION:

Select the desired mounting locations and make cutouts per template. Refer to the Dimensions Diagram.

Check that the two mounting screws will start into the Control Head. Remove Control Head from cutout.

Run cable/harnesses between Processor and Control Head. Label both ends with Station it connects (EXAMPLE: Port, Center, or Starboard; Port Thrust, Port Throttle; etc.)

Dimensions

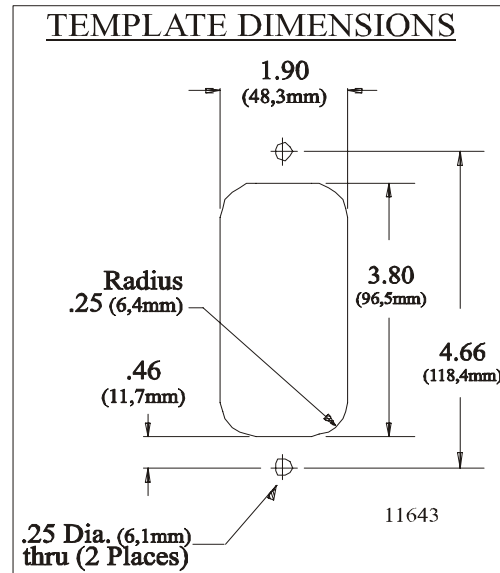
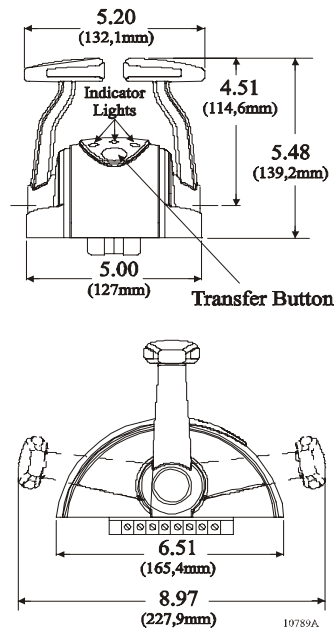

There are two types of Control Head connections available: Plug or Terminal Connected. Both types may be used with MicroCommander, ClearCommand, or CruiseCommand using the appropriate cable or harness. Follow the appropriate steps for the Control Head that has been supplied for your system.

Standard Cable

Strip back the PVC cover on the shielded cable approximately 2-1/2" (63,5mm) at the Control Head.

At the Control Head end of the cable strip and cut off the shielding and drain wire flush with the end of the PVC cover (the drain wire at the Control Head is not connected to ground).

Strip 3/8" (9,5mm) insulation off each wire.

Twist the individual strands of the wires to minimize fraying.

Crimp a locking fork terminal (included with each Control Head) to each of the conductors.

Make connections to the Control Head as indicated in the following TERMINAL CONNECTIONS diagrams.

Pluggable

Plug Control Head cable into the pigtail at the Control Head. (Ensure the correct Processor Cable is being plugged into the corresponding Control Head lever pigtail).

When connecting the plugs, ensure that the release button or buttons are depressed and held until plug is fully connected or disconnected.

Connecting or disconnecting plugs without depressing and holding the release button or buttons will damage the plug.

ALWAYS REFER TO THE MANUAL THAT IS SUPPLIED WITH THE CONTROL SYSTEM FOR ANY UNIQUE CONTROL HEAD CONNECTIONS FOR YOUR SYSTEM.

When cable connections are complete, MOUNT Control Head to the console using the two (2) mounting screws and washers supplied with the Control Head.

CABLE/HARNESS CONNECTIONS:

Dual Control Head Connections TERMINAL CONNECTIONS

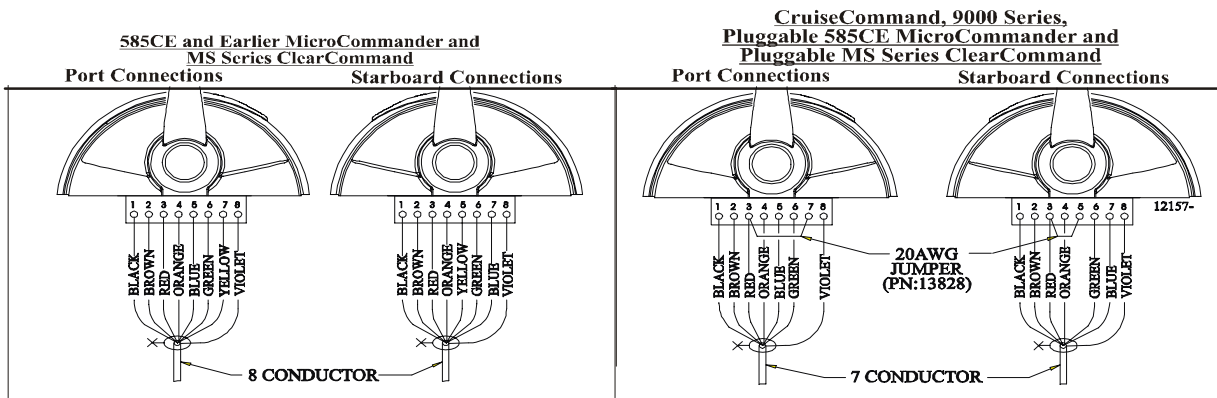

Cable/Jumper connections 5 and 7 at the Port and Starboard terminal block are direction sensitive.

MicroCommander/ClearCommand

Port Lever: Terminal 3 Red
Terminal 5 Blue
Terminal 7 Yellow

Starboard Lever: Terminal 3 Red
Terminal 5 Yellow
Terminal 7 Blue

CruiseCommand/9000 Series

Port Lever: Terminal 3 Red & JUMPER
Terminal 5 Blue
Terminal 7 JUMPER

Starboard Lever: Terminal 3 Red & JUMPER
Terminal 5 JUMPER
Terminal 7 Blue

PLUGGABLE CONNECTIONS

Pluggable Control Heads are supplied with a harness pigtail for each lever. When disconnecting/connecting the plugs, ensure that the release button or buttons are depressed and held until plug is fully disconnected or connected. Disconnecting/connecting plugs without depressing and holding the release button or buttons WILL damage the plug.

Aft Facing Control Heads

For dual lever Control Head Stations that have the user facing aft: Reverse connections 5 and 7.

For single lever Control Head Stations that have the user facing aft and the one Control Head lever on the user's right, reverse connections 5 and 7.

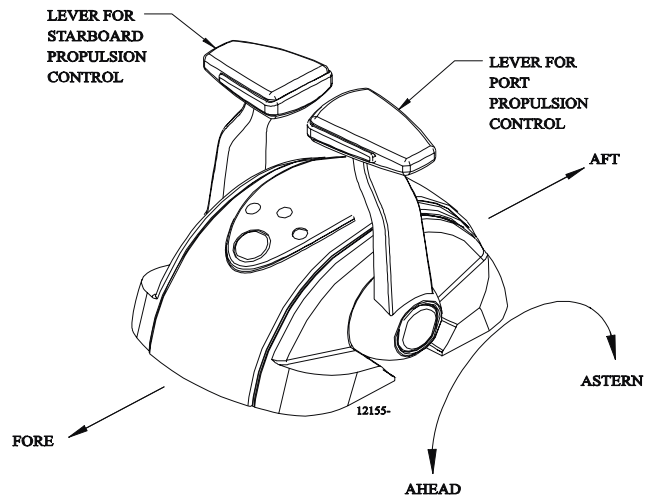

Handheld Control is an option. Contact your ZF Marine Electronics Dealer for further information on Handheld requirements and options.

0.25 Diameter (6,1mm) through Holes
(2 Holes)

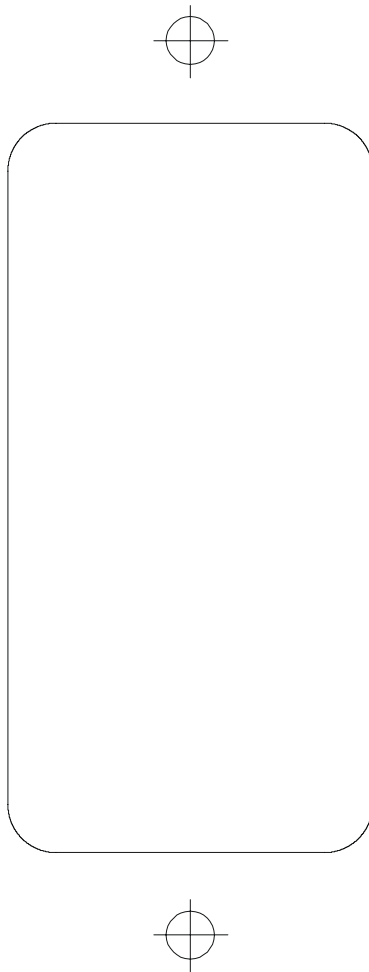



700 Series Standard Control Head Variations

This Service Sheet reflects all current variations of the standard 3-detent ZF Marine Electronics 700 Series Control Heads.

Part Numbering Configurations

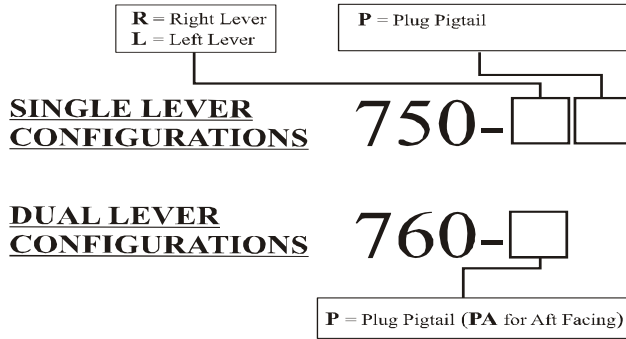

Detents Available

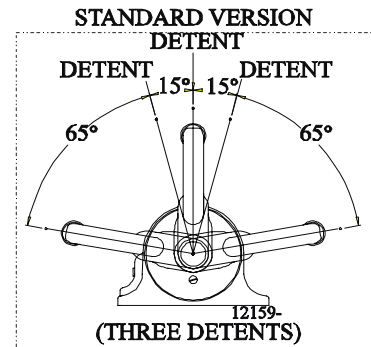

REQUIREMENTS:

MicroCommander/ClearCommand: one (1) 8-Conductor Cable per Control Head lever.

Pluggable MicroCommander/ClearCommand: one (1) Control Head Harness per Control Head lever.

CruiseCommand: one (1) Control Head Harness per Control Head lever.

Included with the Control Head:

- (4) Flat-washer - Stainless Steel, 1/4 inch
- (4) Screw - Stainless Steel, Philip Pan Head, 1/4 inch-20 x 1-3/4 inch
- (4) Nut - Stainless Steel, 1/4 inch-20
- (14) Terminal - Flanged For, #6
- (2) Liquid Tight Connector (in addition to those installed at the factory)

When the Control Head is properly mounted on a console, the Control Head is watertight.

Dimensions

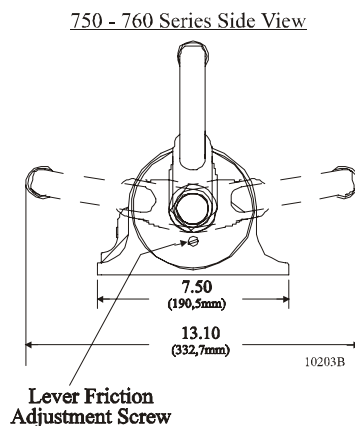
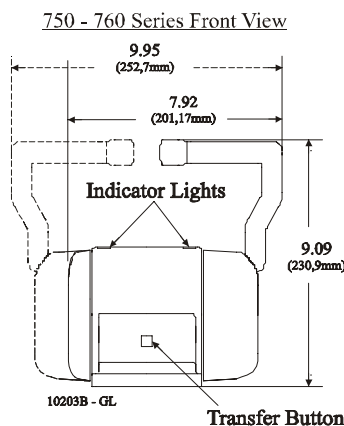

Template Dimensions

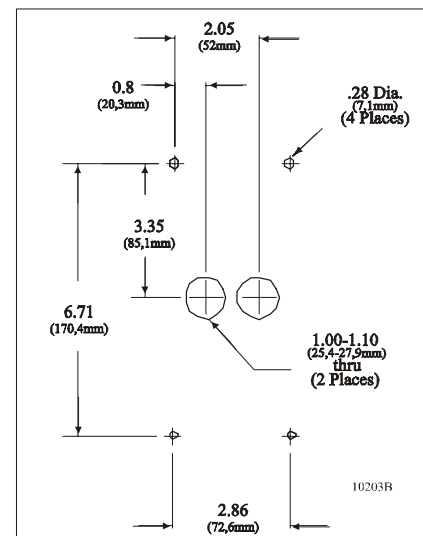

MOUNTING AND INSTALLATION:

Select the desired mounting locations and drill screw and cable holes as indicated on the template diagram. Refer to the Dimensions Diagram on the next page.

Run cable/harnesses between Processor and Control Head. Label both ends with the Station it connects (EXAMPLE: Port, Center, or Starboard; Port Thrust, Port Throttle; etc.)

There are two types of Control Head connections available: Plug or Terminal Connected. Both types may be used with MicroCommander, ClearCommand, or CruiseCommand using the appropriate cable or harness. Follow the appropriate steps for the Control Head that has been supplied for your system.

Standard Cable

Remove the six screws holding the bottom cover of the Control Head housings and set aside.

Insert cable through the correct cable grip in the bottom cover.

Strip back the PVC cover on the shielded cable approximately 2-1/2" (63,5mm) at the Control Head.

At the Control Head end of the cable strip and cut off the shielding and drain wire flush with the end of the PVC cover (the drain wire at the Control Head is not connected to ground).

Strip 3/8" (9,5mm) insulation off each wire.

Twist the individual strands of the wires to minimize fraying.

Crimp a locking fork terminal (included with each Control Head) to each of the conductors.

Make connections to the Control Head as indicated in the following TERMINAL CONNECTIONS diagrams.

Pluggable

Plug Control Head cable into the pigtail at the Control Head. (Ensure the correct Processor Cable is being plugged into the corresponding Control Head lever pigtail).

When connecting the plugs, ensure that the release button or buttons are depressed and held until plug is fully connected or disconnected. Connecting or disconnecting plugs without depressing and holding the release button or buttons will damage the plug.

ALWAYS REFER TO THE MANUAL THAT IS SUPPLIED WITH THE CONTROL SYSTEM FOR ANY UNIQUE CONTROL HEAD CONNECTIONS FOR YOUR SYSTEM.

When cable connections are complete:

Replace Control Head bottom cover using the six (6) mounting screws removed earlier. Ensure seal is in place.

Tighten watertight cable grip(s).

Remove front cover from the Control Head
Mount Control Head with supplied hardware.

Replace front cover when mounting is complete.

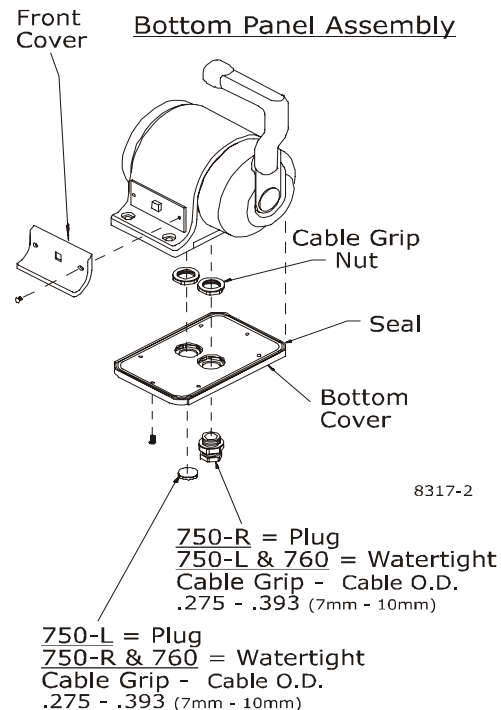

CABLE/HARNESS CONNECTIONS:

Dual Control Head Connections TERMINAL CONNECTIONS

750- 760 Series Connections

585CE and Earlier MicroCommander and
MS Series ClearCommand

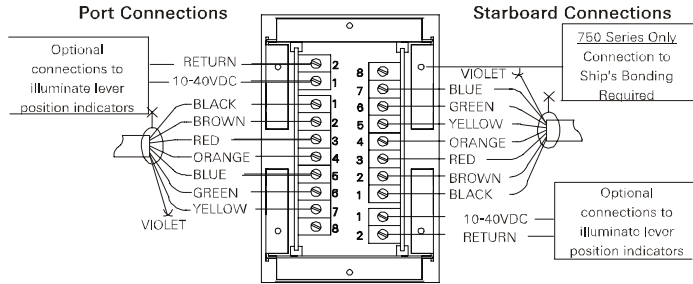

Cable/Jumper connections 5 and 7 at the Port and Starboard terminal block are direction sensitive.

585CE and Earlier MicroCommander and MS Series ClearCommand

Port Lever:

Starboard Lever:

Terminal 3 Red

Terminal 3 Red

Terminal 5 Blue

Terminal 5 Yellow

Terminal 7 Yellow

Terminal 7 Blue

CruiseCommand, 9000 Series, Pluggable 585CE MicroCommander and Pluggable MS Series ClearCommand

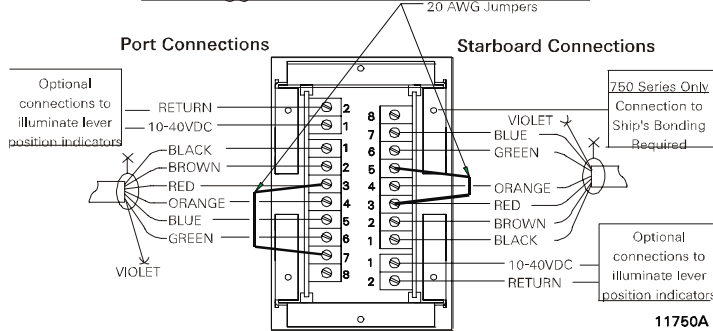

CruiseCommand, 9000 Series, Pluggable 585CE MicroCommander and Pluggable MS Series ClearCommand

Port Lever:

Starboard Lever:

Terminal 3

Terminal 3

Red & JUMPER Red & JUMPER

Terminal 5 Blue

Terminal 5 JUMPER

Terminal 7 JUMPER

Terminal 7 Blue

PLUGGABLE CONNECTIONS

Pluggable Control Heads are supplied with a harness pigtail for each lever. When disconnecting/connecting the plugs, ensure that the release button or buttons are depressed and held until plug is fully disconnected or connected. Disconnecting/connecting plugs without depressing and holding the release button or buttons WILL damage the plug.

Aft Facing Control Head

For dual lever Control Head Stations that have the user facing aft:
Reverse connections 5 and 7.

For single lever Control Head Stations that have the user facing aft and the one Control Head lever on the user's right, reverse connections 5 and 7.

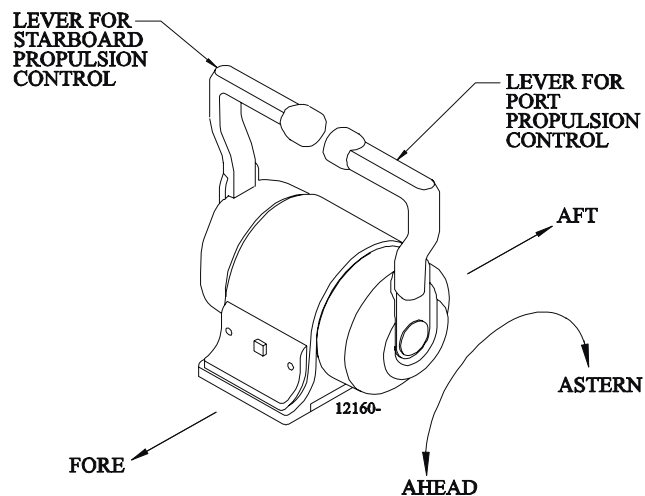

Handheld Control is a Station option. Contact your ZF Marine Electronics Dealer for further information on Handheld requirements and options.

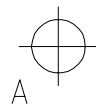
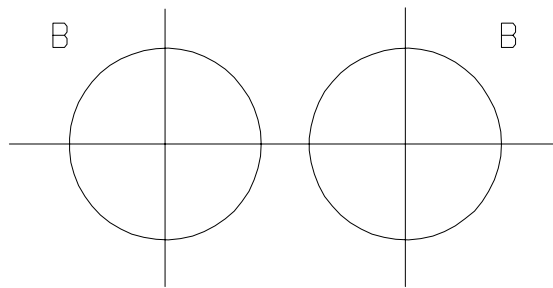
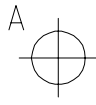

"A" HOLES \varnothing .28

"B" HOLES \varnothing 1.00 - 1.10

11403-



400 Series Weather Mount Enclosure

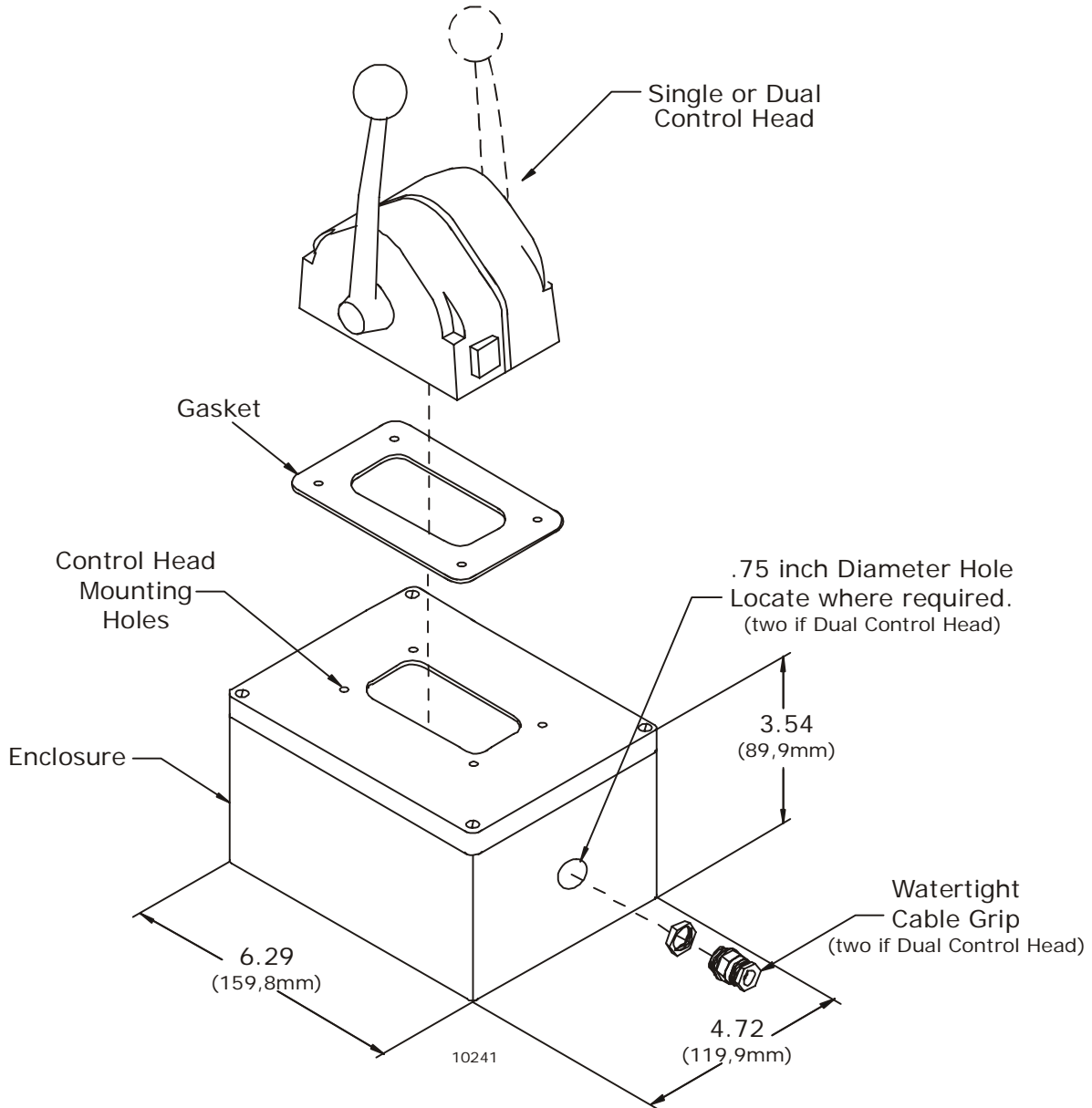

Deck Mount or Exposed Mount

Ideal for outside Weather Mount

To prevent internal condensation and moisture build up the mount is drilled to allow air circulation.

Part No. 12110

Deutsch Connector Assembly

DT Type

Step 1: Contact Removal



1. Remove wedgelock using needle-nose pliers or a hook shaped wire. Pull wedge straight out.



2. To remove the contacts, gently pull wire backwards, while at the same time releasing the locking finger by moving it away from the contact with a screwdriver.



3. Hold the rear seal in place, as removing the contact may displace the seal.

Step 2: Wire Stripping

Solid Contacts

Contact Part Number	Wire Gauge Range	Strip Length (inches)
0460-202-20141 0462-201-20141	20 AWG	.156-.218
0460-202-16141 0462-201-16141	16, 18 & 20 AWG	.250-.312
0460-215-16141 0462-209-16141	14 AWG	.250-.312
0460-204-12141 0462-203-12141	12 & 14 AWG	.222-.284
0460-204-08141 0462-203-08141	8 & 10 AWG	.430-.492
0460-204-0490 0462-203-04141	6 AWG	.430-.492

Step 3: Contact Crimping

Use Crimp Tool #HDT48-00



1. Strip insulation from wire. (See Step 2).
2. Raise selector knob and rotate until arrow is aligned with wire size to be crimped.
3. Loosen locknut, turn adjusting screw in until it stops.



4. Insert contact with barrel up. Turn adjusting screw counter-clockwise until contact is flush with indenter cover. Tighten locknut.



5. Insert wire into contact. Contact must be centered between indicators. Close handles until crimp cycle is completed.
6. Release handles and remove crimped contact.

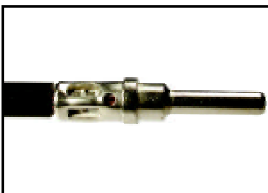

7. Inspect terminal to ensure that all strands are in crimp barrel. **NOTE:** Tool must be readjusted for each type/size of contact. Use HDT04-08 for size 8 and 4 contacts.

Step 4: Contact Insertion



1. Grasp crimped contact approximately (25.2 mm) one inch behind the contact barrel.



2. Hold connector with rear grommet facing you.



3. Push contact straight into connector grommet until a click is felt. A slight tug will confirm that contact is properly locked in place.



4. Once all contacts are in place, insert wedgelock with arrow pointing toward exterior locking mechanism. The wedgelock will snap into place. Rectangular wedges are not oriented. They may go in either way. **NOTE:** The receptacle is shown –use the same procedure for plug.

DEUTSCH
INDUSTRIAL PRODUCTS DIVISION



LADD
Exclusive Authorized U.S. Distributor
(800) 223-1236



Automatic Power Selector (APS) Model: 13505

A) GENERAL INFORMATION

The APS (Automatic Power Selector), Model 13505, provides a simple, solid state solution to the need for routing redundant DC power sources for vital electronic equipment while maintaining isolation of the DC power sources.

Two independent batteries rated at the same nominal voltage are wired to separate terminals on the APS and internal diodes maintain total isolation between them. A single output terminal is wired to the ZF Marine Electronics Propulsion Control System.

The APS is rated for loads of up to 70 Amps on 12-24V systems. The unit is ruggedly constructed with heavy-duty wiring studs and epoxy-potted components in an anodized aluminum case.

B) APS SPECIFICATIONS

Model: 13505

Maximum Load Current: 70 amps

Operating Temperature: -40 degrees C to +80 degrees C; derate linearly from 100% @ 50 degrees C to 70% @ 80 degrees C

Voltage Drop: 0.7 VDC @ 50% load; 0.9 VDC @ full load

Dimensions: 3.25" x 4.5" x 3.1" (8,3 x 11,4 x 7,9 cm)

C) MATERIALS PROVIDED

The **single** APS is supplied with a hardware packet containing (6) hex nuts, (3) lock washers, (4) self-tapping mounting screws, (1) instructions diagram.



NOTE: Not all of the hardware will be used in the installation; some spares are provided. Nut size is M-6.

The **twin** APS is supplied with (2) single APS hardware packets.

D) INSTALLATION

Refer to the installation Drawing 11488D.

1. Shut off all charging sources and disconnect the negative (ground) side of each battery which will be wired to the APS.
2. Mount the APS(s) in a suitable location which will keep wire runs to a minimum length, and is (preferably) ventilated, for cooler operation. The case of the APS is electrically isolated from the internal diodes, so mounting on either a metal or non-metal surface is acceptable.
3. Complete the wiring as indicated on either Drawing 11488D-1 or 11488D-2.
4. Reconnect the negative battery posts.

E) IMPORTANT NOTE ABOUT BATTERY SOURCES

Whenever the load is turned on, it can be drawing power from the batteries. Therefore, if the batteries are not simultaneously being recharged, or if charging will not be available for an extended period, it is recommended that the load be shut off to prevent complete discharge of batteries.

Drawing 11488D-1 Twin Screw Single APS Connection & Alternate Remote Switch

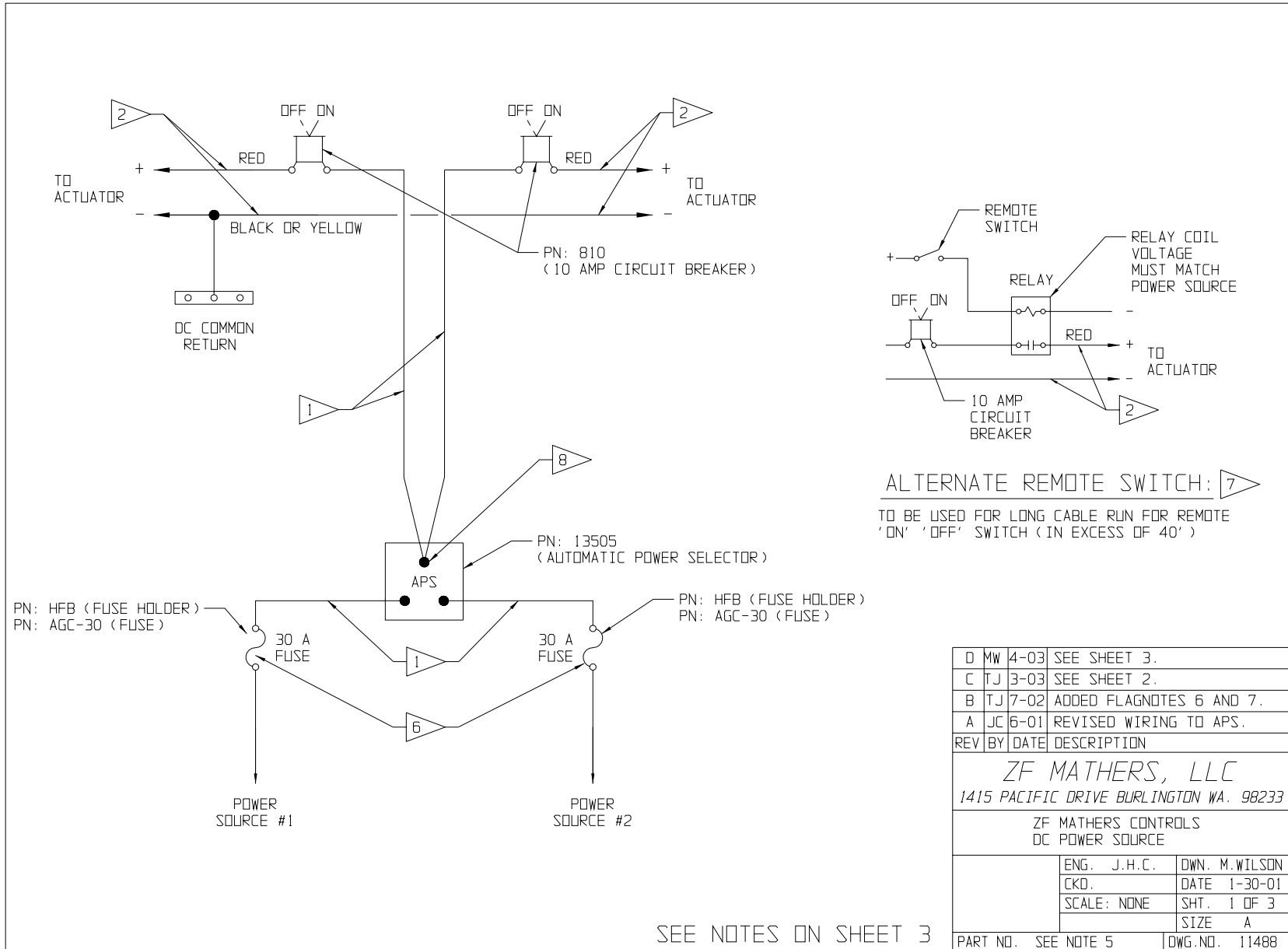

Drawing 11488D-2 Twin Screw Dual APS Connections

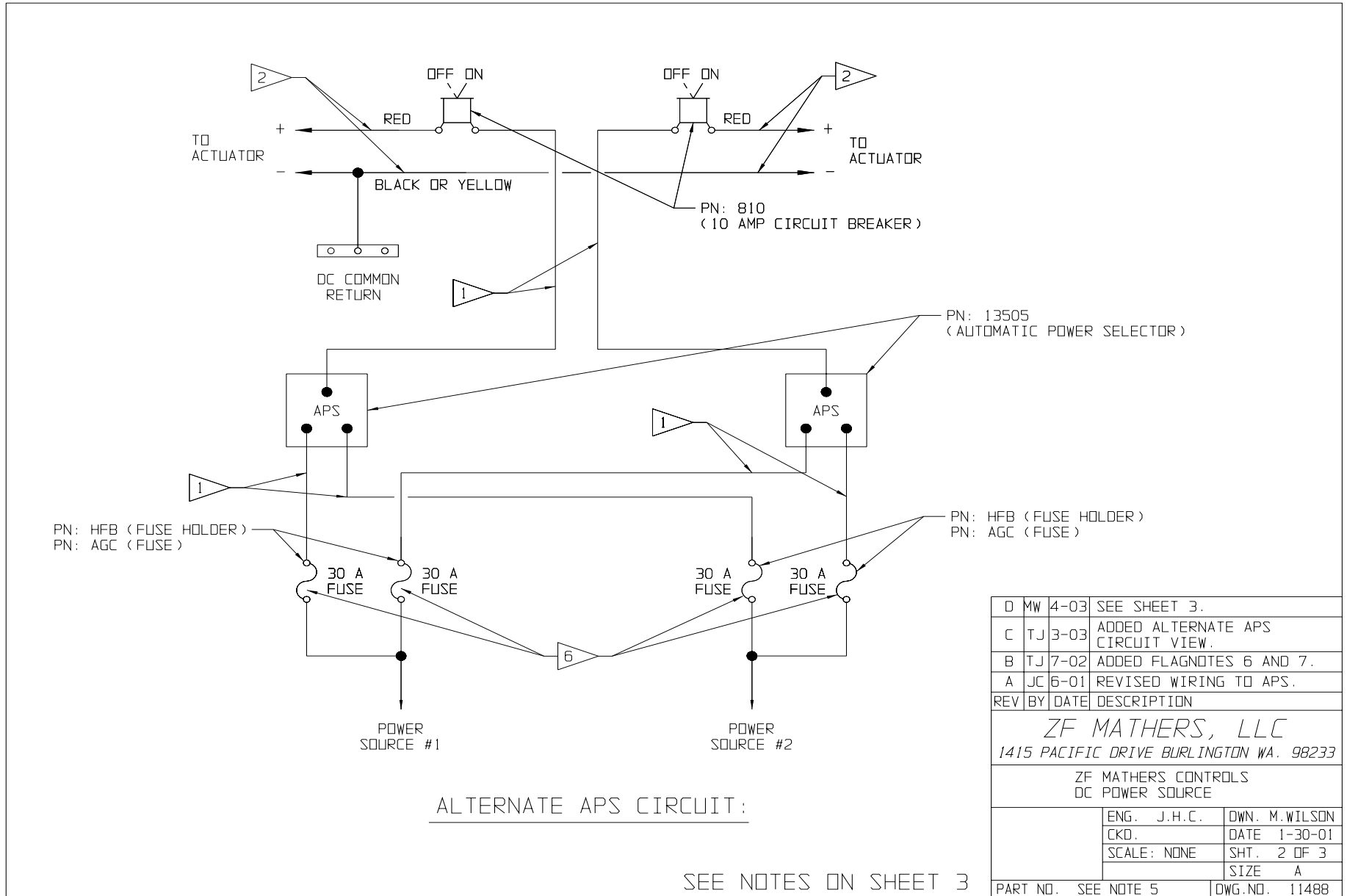

Drawing 11488D-3 APS Notes Page

NOTES:

1 WIRE SIZE (REF ABYC E9.15.9 10%)

12VDC POWER SYSTEMS:

0-15'	(0-4,6M)	12 AWG	(#4 METRIC EQUIVALENT)
15'-25'	(4,6-7,6M)	10 AWG	(#6 " ")
25'-40'	(7,6-12,2M)	8 AWG	(#10 " ")
40'-70'	(12,2-21,3M)	6 AWG	(#16 " ")

24VDC POWER SYSTEMS:

0-20'	(0-6,1M)	14 AWG	(#2,5 METRIC EQUIVALENT)
20'-30'	(6,1-9,1M)	12 AWG	(#4 " ")
30'-50'	(9,1-15,2M)	10 AWG	(#6 " ")
50'-80'	(15,2-24,3M)	8 AWG	(#10 " ")

2 WIRE SIZE. (RECOMMENDED TWISTED PAIR)

12VDC POWER SYSTEMS:

0-20'	(0-6,1M)	14 AWG	(#2,5 METRIC EQUIVALENT)
20'-30'	(6,1-9,1M)	12 AWG	(#4 " ")

24VDC POWER SYSTEMS:

0-40'	(0-12,2M)	14 AWG	(#2,5 METRIC EQUIVALENT)
40'-65'	(12,2-19,8M)	12 AWG	(#4 " ")

3. APS OUTPUT IS STRICTLY FOR ZF MATHERS CONTROLS.

4. POWER SOURCES MAY BE 12 OR 24 VOLTS DC.

5. SINGLE SCREW KIT - PN: 13983.

PN: 13505 (AUTOMATIC POWER SELECTOR)	QTY 1
PN: 810 (10 AMP CIRCUIT BREAKER)	QTY 1
PN: AGC-30 (30 AMP FUSE)	QTY 2
PN: HFB (FUSE HOLDER)	QTY 2

TWIN SCREW KIT - PN: 13984.

PN: 13505 (AUTOMATIC POWER SELECTOR)	QTY 1
PN: 810 (10AMP CIRCUIT BREAKER)	QTY 2
PN: AGC-30 (30 AMP FUSE)	QTY 2
PN: HFB (FUSE HOLDER)	QTY 2

6 MAXIMUM WIRE SIZE ALLOWED IN FUSEHOLDER IS 12 AWG. IF A LARGER WIRE SIZE IS REQUIRED FOR INSTALLATION, THE CUSTOMER SHALL PROVIDE AN APPROPRIATE FUSE AND FUSE HOLDER. (SUGGESTED MANUFACTURER BLUE SEA SYSTEMS, MAXI FUSE BLOCK SERIES).

7 IF THIS CONFIGURATION IS USED WITH AN ELECTRONIC ENGINE THE CIRCUIT BREAKER MUST BE TURNED ON PRIOR TO APPLYING POWER TO THE REMOTE SWITCH.

8 SEE FIGURE 1 BELOW FOR THE SUGGESTED HARDWARE STACK FOR SYSTEMS UTILIZING MULTIPLE OUTPUTS FROM THE PN: 13505 (AUTOMATIC POWER SELECTOR).

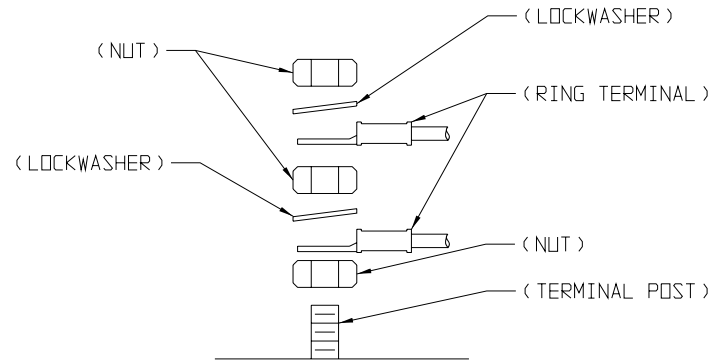

FIGURE 1

REV	BY	DATE	DESCRIPTION
D	MW	4-03	REVISED FLAGNOTES 1 & 2.
C	TJ	3-03	ADDED FLAGNOTE 8. REVISED FLAGNOTE 6.
B	TJ	7-02	ADDED FLAGNOTES 6 AND 7.
A	JC	6-01	SEE SHEET 1.

ZF MATHERS, LLC
1415 PACIFIC DRIVE BURLINGTON WA. 98233

ZF MATHERS CONTROLS
DC POWER SOURCE

ENG.	J.H.C.	DWN.	M.WILSON
CKD.		DATE	1-30-01
SCALE:	NONE	SHT.	3 OF 3
		SIZE	A

PART NO.	SEE NOTE 5	DWG.NO.	11488
----------	------------	---------	-------



Grounding (Bonding)

Grounding (Bonding) - 46 CFR 111.05 and ABYC Section E-11

Grounding (Bonding) should be done according to ABYC Section E-11 and Code of Federal Regulations 46 CFR 111.05.

Each grounded system must have only one point of connection to ground regardless of the number of power sources operating in parallel in the system

A vessel's hull must not carry current as a conductor. A metallic hull, or the bonding and DC grounding systems, shall not be used as a return conductor.

There are some limited exceptions: (1) Impressed current cathodic protection systems. (2) Limited and locally grounded systems, such as a battery system for engine starting that has a one-wire system and the ground lead connected to the engine. (3) Insulation level monitoring devices if the circulation current does not exceed 30 milliampères under the most unfavorable conditions. (4) Welding systems with hull return except vessels subject to 46 CFR Subchapter D.

Grounding conductors should be green or green with a yellow stripe.

References:

- CFR Sec. 111.05-13, Sec. 111.05-11
- ABYC E-11 11.5.2.2, ABYC E-11.4, ABYC 11-18.

Grounding^a

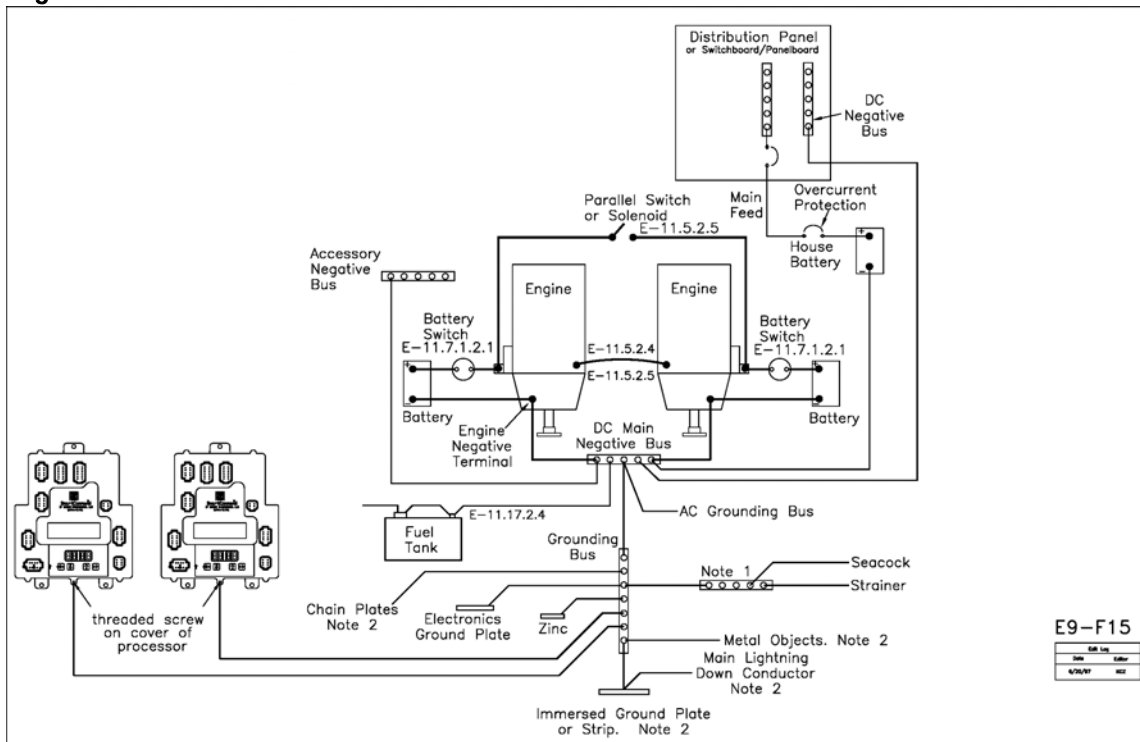

^a Grounding is used courtesy of American Boat and Yacht Council.

All parts of figure except processors and processor connection ©
2003 American Boat and Yacht Council

Metal - Hull Vessels

The hull of a metal hull vessel may serve as the common grounding conductor. If it is desirable for the item being installed to be bonded to the vessel grounding system, and the installation or mounting method does not provide the desired path, a separate grounding conductor may be required.



References and Parts Source

A) REFERENCES

1. American Boat & Yacht Council (ABYC)
 - 3069 Solomons Island Road
 - Edgewater, MD 21037-1416
 - E-3 Wiring Identification on Boats
 - E-11 AC and DC Electrical Systems on Boats
 - H-2.4e or 32.4g Ambient Temp. 50 degrees C
 - P-24 Electric/Electronic Propulsion Controls
2. Code of Federal Regulations
 - 33 CFR 183 Subpart I - Electrical Systems
 - 33 CFR 183.410 Ignition protection
 - 33 CFR 183.415 Grounding
 - 33 CFR 183.425 Conductors: General
 - 33 CFR 183.430 Conductors in circuit of less than 50 Volts
 - 33 CFR 183.445 Conductors: Protection
 - 33 CFR 183.455 Over-current and Protection: General
 - 46 CFR 111.01 - 15(b) Ambient Temp. Machinery Spaces 50 degrees C
 - 46 CFR 111.05- System Grounds
3. Society of Automotive Engineers
 - 400 Commonwealth Drive
 - Warrendale, PA 15096
 - J1171 External Ignition Protection
 - J1428 Marine Circuit Breakers
 - J378 Marine Engine Wiring
4. National Marine Manufacturers Association
 - 401 North Michigan Avenue
 - Chicago, IL 60611
5. Underwriters Laboratories

B) PARTS SOURCE

Anti-Static Wrist Strap	P/N 517 [Thomas & Betts (P/N AWCC)]
Automatic Power Selector	P/N 13505
Circuit Breaker- UL Approved	P/N 810 [E-T-A (P/N 41-2-514-LN2-10)]
Fuse	P/N 1030 [Bussman (P/N. GDC-1A)]
Relay 12 VDC	P/N 1114 [Potter-Brumfield (P/N KRPA5D6-12)]
Relay 24 VDC	P/N 1122 [Potter-Brumfield (P/N KRPA5D6-24)]
Service Field Test Unit (Break-out Box)	P/N 13927
WAGO Tool	P/N 397 [WAGO (P/N 236-332)]
Field Test Control Head - Dual	P/N 14000



Electronic Propulsion Control Systems Three Year Limited Warranty

Your ZF Marine Electronics product has been designed and manufactured by experienced engineers and craftsmen. ZF Marine Electronics LLC, warrants for the period indicated below, each product to be free from defect in material and workmanship. Repair or replacement, at ZF Marine Electronics option, will be provided if the product, upon ZF Marine Electronics inspection, is found to be properly installed and operated in accordance with ZF Marine Electronics Manual. This warranty does not apply to malfunction caused by damage, unreasonable use, misuse, repair or service by unauthorized persons or normal wear and tear.

A) Coverage Under Warranty

Three years from the date of purchase by the original end user.

Year One

No charge for equipment repair, parts and labor. Up to three hours labor toward troubleshooting and replacement of defective equipment.

Year Two and Three

There is no charge for equipment repairs performed at the factory that are covered under warranty. No labor allowance for troubleshooting and replacement of defective equipment.

B) No Coverage Under Warranty

The following will not be covered under warranty. Travel to and from the job site.

1. Adjustment or calibration of any ZF Marine Electronics equipment.
2. Adjustment or calibration of any associated equipment which may include but not limited to push-pull cables, engine governor or carburetor, transmission or trolling valve.
3. Damage due to accidents, improper installation or handling and or improper storage.
4. Damage due to faulty repairs performed by an unauthorized service representative.
5. Damage due to conditions, modifications or installation contrary to published specifications or recommendations.
6. Original installation charges or start-up costs.
7. Battery service including labor charges related to battery service.
8. Rental of equipment during performance of warranty repairs.
9. Unauthorized repair shop labor, without prior approval from ZF Marine Electronics Service Department.
10. Shop supplies such as connectors, wire, cable, etc.

C) Warranty Service

Please go to www.zf-marine.com or Call 1-425-583-1900 or (U.S. only) 1-800-546-5455 for your nearest ZF Marine Electronics Factory Authorized Dealer.

1. Prior to returning any product to the factory, you must contact ZF Marine Electronics Service Department for a Service Return Authorization (SRA) number. Return the product freight prepaid, marked clearly with the SRA number and a description of the malfunction.
2. If there is a defect covered by warranty, ZF Marine Electronics will, at its option, either repair or replace the defective part or product. If after inspection, ZF Marine Electronics determines that the product is not defective, ZF Marine Electronics will charge a testing fee and return the product to the sender, freight collect.
3. Repair or replacement during the warranty period will not extend the warranty period.
4. All claims must be submitted within 30 days from date of service.
5. Claims for over 3 hours must be pre-approved by the ZF Marine Electronics Service Department.

This Warranty is expressly in lieu of all other Warranties, express or implied. Except to the extent prohibited by applicable law, ZF Marine Electronics hereby disclaims all other implied or express warranties of any kind, including warranties of merchantability and fitness for a particular purpose. Under no circumstances shall ZF Marine Electronics be liable for any consequential damages sustained in connection with the product or its use, including any costs or damages which result from loss of use of the product or any engine or boat with which it is used. ZF Marine Electronics does not authorize any representative or agent to assume for it any obligation or liability other than those expressly set forth above. Some states do not allow limitations on how long an implied warranty lasts or the exclusion or limitation of incidental or consequential damages, so the above limitation may not apply to you. All implied warranties, if any, are limited to the duration of this express warranty. This warranty gives you legal rights, and you may have other rights which may vary from State to State.



Warranty Registration

Processor, Serial # _____ Serial # _____

Number of Remote Stations _____

Purchase Date _____

Dealer's Name _____

Installer's Name _____

Phone Number () _____

Cell Number () _____

Fax Number () _____

E-Mail Address _____

Purchaser's Name _____

Street Address _____

City, State, Zip _____

Phone Number () _____

YOUR VESSEL:

Engine, Make & Model _____

Length _____

Manufacturer _____

ZF Marine Electronics, LLC. Product First Seen At:

Boat Show

Dealer

Magazine

Friend

ZF Marine Electronics, LLC.
12125 Harbour Reach Drive, Suite B
Mukilteo, WA 98275

APPENDIX B



B1 TROUBLESHOOTING GENERAL

The ZF Marine Electronics Control System consists of one Processor per engine, typically mounted in the engine room, and one to four Control Heads located at the vessel's Remote Stations.

In the event that a malfunction occurs, review the appropriate System Diagram and become familiar with the various components, their functions and locations on the vessel.

The following Sections are a list of the main components that make up a typical system, along with a brief description of their functions:

B1-1 Control System Examples

B1-1.1 785CE (Throttle Electronic, Clutch Solenoid or Clutch/Troll Solenoid, up to Four pluggable Stations) Processor

The **785CE** is designed to precisely control speed and direction on vessels equipped with electronic Throttle, solenoid Clutch or Clutch/Troll selection.

B1-2 Typical System Main Components

B1-2.1 Control Head

The primary function of the Control Head is to send out a variable DC voltage to the Processor. This DC voltage is representative of the Control Head's present lever position. In addition to the primary function, the Control Head also has audible (Sound Transducer) and visual (LED) status indications, along with a Transfer Button for taking command and performing other system functions.

B1-2.2 Processor

The Processor receives the variable DC voltage from the Control Head(s) and converts these inputs to the appropriate electronic or electric outputs at the correct time and sequence to the Governor and Gear Box. The information regarding throttle type, throttle/ clutch sequencing, etc., are all stored on memory within the Processor.

B1-2.3 Power Source

All electronic equipment must have power in order to operate. Ensuring a properly charged reliable power source is available and crucial.

The Processor requires a 12 or 24 VDC power system.

The minimum voltage at which the Processor will continue to operate is 8.00 VDC. The maximum allowable voltage is 30 VDC. Exceeding these limits will not damage the Processor, but will render it unusable temporarily. The power supply must be capable of delivering 10 amperes to each Processor on a continual basis and current surges up to 20 amperes.

All cable calculations should be based on a 10 ampere draw with no more than 10% voltage drop.

B1-2.4 Electrical Cables and Harnesses

The function of the Electrical Cables and Harnesses are to move electrical information from one point to another. The ZF Marine Electronics' System has pluggable Harnesses. These Harnesses may have plugs on one end or both, depending on its purpose.



There are Harnesses available for Control Head Interface, DC Power, Start Interlock, Clutch Oil Pressure Interlock and External System Status Indication Circuit.

In addition, the application may require Harnesses for one or more of the following:

- Engine Interface
- Serial Communication
- Shift Interface
- Shift/Troll Interface
- Tachometer Sensor Signal

Prior to attempting to troubleshoot the System, get as much information as possible from the owner or operator. Inspect the System for signs of misadjustments, loose connections, physical damage or water incursion.

Pay special attention to the following items:

- DC Power Source
- Component Location
- Component Condition
- Interconnecting Wiring and Harnesses
- Wire Terminations
- Plug and Socket Pins



B2 TROUBLESHOOTING QUESTIONS

Prior to lifting a tool or stepping on board the vessel, many problems can be resolved by asking the customer the following basic questions:

A) Is the System installed on a Single, Twin or Multiple Screw vessel?

- If the System is installed on a Single Screw vessel, this question does not have much value in narrowing down the source of the problem.
- If the System is installed on a Twin or more Screw application, this question is quite useful, if you ask the following question.
 - 1 Does the problem or symptom occur on the Port, Starboard or both sides?
 - If the problem or symptom occurs on one side only, you have effectively eliminated 50% of the possible causes. For example, the symptom only occurs on the Port side. All of the components on the Starboard side have been eliminated as potential causes.
 - If the problem occurs on both the Port and Starboard sides, you must ask yourself: What do both sides have in common? Most likely answer to your question would be the DC Power source.

B) What is the Part Number and Serial Number of the Processor?

Whenever the factory is called for technical assistance, the part number and serial number will be required. These numbers provide the Service Technician information about the operating characteristics of the Processor. The numbers are located on the Processor's front cover.

C) How many Remote Stations are there? (If only one Remote Station is present, not much will be gained by asking this question. However, if more than one Remote Station is being used, command should be taken from one of the other Stations to see if the problem occurs from another Station.)

- If the problem occurs from more than one Remote Station, the odds are that the Control Heads are not the cause of the trouble.
- If the problem occurs at one Remote Station only, there is a greater chance of the Control Head or the Control Head Harness of being the cause.

D) Are any tones generated when the problem occurs?

The tones are used to bring the operator's attention to a possible condition or problem.

The following basic tones can be produced on all Systems (refer to Section B5 - AUDIBLE TONES):

- **Slow Repetitive Tone**
- **One Long- Three Short Tones**
- **Steady Tone**
- **Three Second Steady Tone**

The following tone can be produced on all Systems using Solenoid Clutches (refer to Section B5 - AUDIBLE TONES):

- **One Long - One Short Tone**

E) Are there any Error Messages displayed on the Processor's Display LED?

In addition to generating a tone, at any time the system detects a malfunction or fault, an error message will be displayed at the Processor. Refer to Section 8 - Table B8-1 "Basic Control System Error Codes", for an explanation of the errors.

F) What is the status of the Control Head in command's red LED?



The red LED(s) will be in one of the following states:

Lit Steady

When the red LED is **Lit Steady**, this indicates that the Station is in command and in Normal operative mode.

Not Lit

When the red LED is **Not Lit**, that Station is not in command, or there is no power to the Control System.

Blinking Slowly

A **Slow Blinking** red LED indicates that the Control Head is in Throttle Only Mode (Warm-up Mode).

Blinking Rapidly

A red LED that is **Blinking Rapidly** indicates that the System is in Troll Mode.

G) Has anything on the vessel changed shortly prior to or when the problem arose?

This question is often overlooked, but should be considered. Obvious changes such as additions or changes to the electrical/ electronic equipment onboard can affect the electrical load and in turn the Processor's power supply.

Ask the operator if any changes or maintenance to the vessel's machinery have occurred lately. Items which are significant to you, the technician, may not seem so to the casual owner or operator. An example would be changes to the engine's fuel system.

Ask about changes, that when initially considered, appear to have nothing to do with the Control System. An example where this really occurred was on a vessel which had recently been repainted. For unknown reasons, the painter took it upon himself to disconnect the connections at a Control Head and then reconnected it incorrectly.

In many cases, these simple questions can resolve a problem with no further action from you, the technician. Take the time to consider these questions. In the long run, you will save yourself and the customer a lot of time and money.



B3 TROUBLESHOOTING PROBLEM RESOLUTION

If the problem could not be resolved by asking the questions in the previous section, a careful inspection of the Control System may be the next step. Even in situations where the problem was found and corrected, it is good practice to always perform a careful inspection of the entire Control System each and every time you are asked aboard a boat.

Always verify that the installation of the System is in compliance with the Installation Manual by carefully inspecting the following:

B3-1 DC Power

- A) Ensure that the Processor(s) and Clutch is connected to a properly charged 12 or 24 VDC battery through a 10 Ampere circuit breaker.
- B) To ensure reliable power to the Processors an APS (Automatic Power Selector) is strongly recommended. The APS take inputs from two separate power sources. Whichever power source is at the higher voltage level, will be automatically switched through.
- C) Refer to Automatic Power Selector information in Appendix A.

B3-2 Component Location

B3-2.1 Control Heads

There are virtually no restrictions regarding the location of the 400 Series and MC2000 Series Control Heads, as long as the bottom is protected from the environment. The 500 Series Control Heads must be mounted to a console and the 700 Series are waterproof from top to bottom.

Refer to Appendix A - Control Head Reference Sheet for Installation requirements.

B3-2.2 Processors

The Processors are typically mounted in the engine room, while maintaining a minimum distance of 4 feet (1,22m) from sources of high heat and EMI (Electro Magnetic Interference) or RFI (Radio Frequency Interference).

Refer to Section 3 - PLAN THE INSTALLATION for requirements.

B3-3 Component Condition

B3-3.1 Control Heads

Inspect for any signs of corrosion due to water incursion. If hard-wired, ensure that all the fork connectors are properly secured to the terminal. Verify all wires are fully crimped and do not pull loose.

B3-3.2 Processors

Inspect the Processor for any signs of physical damage.

B3-4 Interconnecting Wiring and Harnesses

- A) Inspect the wire terminations for loose connections, corrosion or wire strands.
- B) Inspect the Harness's pins and sockets for bent pins, torn boots or any signs of corrosion.



The first step in troubleshooting a problem with the Propulsion System is to determine if the problem is with the Control System or something external to the System. In all cases a Control System malfunction will alert the operator of the potential problem. This is accomplished through the audible tone emitted at all Remote Stations. When an audible tone is emitted, it will be accompanied by an Error Message at the Processor. Also, in many cases, the Control System will alert the operator to a problem external to the Control System.

The following are examples of components both internal and external to the Control System which could be a source of trouble:

Table 1: Examples of Internal/External Components

Internal	External
Processor	DC Power Source
Control Head	Engine
Interconnecting Wiring (Harnesses)	Transmission

The following pages should give you a good guideline for making this determination. There is no need to troubleshoot the system to any point further than one of the main components listed above. If the fault is found to be with a Control System component, that component is simply replaced. If the fault is found to be with one of the external components, replace or repair the defective component or contact a qualified mechanic.



B4 TROUBLESHOOTING DIAGNOSTIC MENU

The Processor has built in diagnostics designed to assist the technician in determining the cause of a problem. The following information is available to view at any time:

- Applied Battery Voltage
- Tachometer Sender Frequency
- Stations 1- 4 A/D's
- Stations 1- 4 Transfer Button Status
- Software Revision Level

In order to access this information, follow the steps below:

A) Locate the Display LED on the Port or Starboard Processor. The Display LED will have a running dash pattern moving from left to right while the program is running in Normal Operation.

Figure 1: Display Function Code



B) Depress the Up or Down Push Button to activate the Function Code List. The characters **A001** will be shown on the Display like Figure 1:

Figure 2: Display Troubleshooting Function



C) Depress the Up or Down Push Button repeatedly until **H000** is displayed like Figure 2:.

Figure 3: Display Function Blinking
Function Code is Blinking



D) Depress and hold the Left and Right Push Buttons simultaneously until the **H0** begins to blink. (Figure 3:) Release the Push Buttons; the applied battery voltage will now be displayed:

- The displayed value is in "real time" and provides a rough estimate of the DC voltage applied to the Processor. The reading is accurate to within 0.50 DC. Refer to Figure 4:

Figure 4: Example Display of Applied Battery Voltage



E) In addition to the applied battery voltage, scrolling through the **Diagnostics Menu** by pressing the Up or Down Push Button can also show the Tachometer Sender Frequency (Figure 5):

Figure 5: Example Display of Tach Sensor Frequency

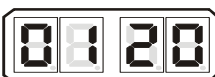

- The information shown is the actual frequency output by the Tachometer Sender. This signal is utilized in "Closed Loop" Synchronization or "Closed Loop" Troll (future) systems
- The Control Head's lever position, and the resulting output of the Station's Control Heads can always be monitored. This is regardless of whether that Station is in command or not. Note the placement of the decimal points in the following examples, which show all Stations with the lever positioned at the Neutral/Idle position. This will be covered in further detail later.

Figure 6: Example Display Control Head Lever Current Positions



F) The current status of all the Control Head's Transfer Buttons can be monitored within the **Diagnostics Menu**. A **1** indicates a closure (depressed Transfer Button) of the switch, while a **0** indicates an open switch.



Figure 7: Example Display Control Head Transfer Button Status View



- G) Depressing the Up or Down Push Button one more time will show the current revision level of the software. This feature will provide invaluable information in the years to come. Determining the characteristics or capabilities of a certain Processor will be as simple as selecting this feature.

Figure 8: Example Display of Software Revision Level View



- H) Pressing the Up or Down (Scroll) Push Button once more, returns you to the Applied Battery Voltage.
- I) The Diagnostic Menu can be exited two ways:
- Do not touch any Push Buttons for 5 minutes. The system will automatically exit.
 - Depress the Left Push Button until **H000** appears. You may now scroll through the Set Up Menu.



B5 TROUBLESHOOTING AUDIBLE TONES

As mentioned previously, there are various tones emitted from the Control Head if an error were to occur.

B5-1 Basic Control System Tones

These basic tones are as follows:

B5-1.1 Slow Repetitive Tone



The Slow Repetitive Tone, also referred to as the “Initialization Tone” is the tone you hear at all Remote Stations when power is initially applied to the control system. When this tone is heard, you know for a fact that the following are true:

- Power has just been applied to the system.
- The Software Program is running normally.
- The Processor is commanding the throttle to Idle.
- The Processor is commanding the clutch to Neutral.

This is a normal tone when power has first been applied to the Processor and no Control Head has taken command. However, if during normal operation the engine’s throttle drops to Idle, followed by the clutch to Neutral, the Control Head’s red LED goes out and a slow repetitive tone is heard at all remote stations, the tone may be an indication of a problem. This indicates that the voltage at the Processor has momentarily dropped below 8 VDC and then returned to a normal operational level. This could be due to:

- Loose battery power cable connection.
- Under-charged or defective battery.
- Voltage drop due to current flow.

In order to pinpoint the exact cause of the low voltage at the Processor, perform the following checks:

- A) Check the Display on the Processor for Error Messages. Error Message **55** may appear indicating Under Voltage. One or more of Error Messages **37** through **53** may also be displayed. This is due to the momentary loss of serial communication between the two Processors. Take note that the Under Voltage error is not only dependent on low voltage, it is also dependent on the duration of the low voltage. The possibility exists that an error message would not be displayed if the duration of the low voltage was short enough. However, the other symptoms mentioned above still occur.
- B) In either case, follow the procedure listed under Section B4 - DIAGNOSTIC MENU until the Applied Battery Voltage is displayed. Take note of the applied voltage.
- C) Go to the battery or Main Distribution Panel which is feeding power to the Processor. With a DC Voltmeter, measure the voltage at this power source. The battery voltage should be greater than 12.4 Volts in 12 VDC systems and 24.8 Volts in 24 VDC systems. If not, the battery or it’s charging system needs servicing.
- D) The voltage differential between the power source and the Processor should not exceed 1.2 Volts in 12 VDC systems and 2.4 Volts in 24 VDC systems. If so, there is high resistance somewhere between the battery and Processor.



NOTE: If an APS is being utilized in the power circuit, take into account the 0.7 VDC forward voltage drop of the diodes. This would increase the permissible differential between power source and Processor from 1.2 to 1.9 VDC in 12 VDC circuits and 2.4 to 3.1 VDC in 24 VDC circuits.



- E) High resistance, resulting in a differential voltage of 1.2 Volts (12 VDC Systems) or 2.4 Volts (24 VDC Systems) or greater, may be the result of corroded or tarnished connections, dirty or pitted relay contacts or an improperly sized power cable.
- F) If the voltage differential is less than 1.2 Volts (12 VDC Systems) or 2.4 Volts (24 VDC Systems), which is what you would typically expect, a loose connection may exist between the power source and the Processor. The vibration experienced while the vessel is underway may intermittently cause the circuit to open. Check all the connections between the power source and the Processor for loose bolts, nuts, etc.

B5-1.2 One Long - Three Short Tones



This tone indicates that there is an invalid command signal at the Station-in-Command.

The Processor expects a DC voltage, representative of the Control Head's present lever position.

This voltage is referred to as the "Command Signal". In normally functioning Control Heads, the command signal is between approximately 0.5VDC at Full Astern to 4.40 VDC at Full Ahead.

The command signal is converted by the Processor to a digital representation, referred to as an A/D Count. More on A/D Counts later. If the command signal drops below or exceeds this range, the tone will be generated.

At the same time the tone is heard, throttle command drops to Idle and the clutch will be commanded to Neutral. The following items will cause this to occur:

- An open or high resistance connection between the Control Head and Processor.
- Out of calibration Control Head.
- A defective Control Head.

The exact cause of the malfunction can be found as follows:

- A) Check the Processor's Display for error messages. Most likely, one of error messages **13** thru **28** will be shown. The exact number shown depends on which remote station is experiencing the problem and whether the command signal was too high or too low.
- B) Enter the **Diagnostic Menu** as outlined in Section B4 - DIAGNOSTIC MENU.
- C) Depress the Up or Down (Scroll) Push Button until the appropriate Remote Station is displayed.
 - The Remote Station are identified by the position of the decimal points.
 - Station 1 has no decimal point after the first digit to the far right. The remaining three digits all have decimal points.
 - If the digit to the far left had no decimal point following it, but the remaining three do, this would represent Station 4.

Figure 9: Display Examples of Remote Stations

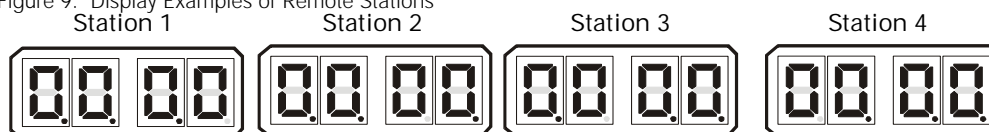

- D) The examples above are shown with no Control Heads connected to any Remote Stations. When a Control Head is connected, the appropriate A/D (Analog/Digital) value for the present position of the Control Head's lever will be shown, as in the following examples:



Figure 10: Display Examples of Remote Stations A/D Values

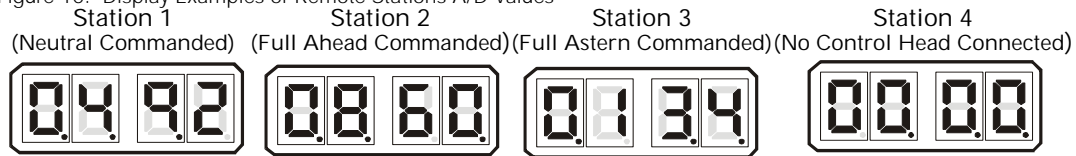

- E) An A/D value is 900 or greater, one of Error Codes **13 to 20** will be shown.
- If the A/D value is greater than 900, but less than 990, one of the following may be the cause:
 - 1 The Control Head's potentiometer is out of calibration.
 - 2 The potentiometer is defective.
 In either case, it is recommended that the Control Head is replaced.
 - If the A/D value is 995 or higher, one of the following may be the cause.
 - 1 JUMPER between pins 3 and 5 (Right hand) Control Heads or pins 3 and 7 (Left Hand) Control Heads is disconnected.
 - 2 If the LED is not lit and no audible tone is heard, the red wire connected between pin 3 of the Control Head and pin 5 of the Processor is open.
- F) If the A/D value is 100 or less, one of Error Codes **21- 28** will be shown.
- If the A/D value is less than 100, but greater than 75, the following may be the cause:
 - 1 The Control Head's potentiometer is out of calibration.
 - 2 The potentiometer is defective.
 - 3 A high resistance connection exists on pin 6 (green wire) between the Control Head and Processor.
 - If the A/D value is less than 75:
 - 1 There is an open wire between pin 6 (green wire) of the Control Head and the Processor.
 - 2 There is an open wire between pin 7 (blue wire) of a right hand Control Head and the Processor.
 - 3 There is an open wire between pin 5 (blue wire) of a left hand Control Head and pin 7 (blue wire) of the Processor.

B5-1.3 Steady Tone

The Steady Tone is an indication to the operator that something has gone wrong within the Control System. The Steady Tone will typically be accompanied by an Error Message on the Processor's Display. If the tone is heard, the Processor's Display must be referred to in order to further diagnosis the problem.

If the Transfer Button is shorted - Tone will cease when command is taken at another Station.

If the Transfer Button becomes shorted for 12 seconds or more during Normal Operation, a steady tone will be produced at all Remote Stations as long as the Transfer Button remains shorted. Full System control remains. Transferring to another Remote Station silences the Steady Tone. Command cannot be regained at the Station until the problem is rectified.



B5-1.4 Three Second Steady Tone



This tone is generated when a fault is detected with the Troll ON/OFF Solenoid or Troll Proportional Solenoid. The tone will also be accompanied with one or more of Error Messages 7 - 10. The System's program/memory must be told of the existence of these solenoids in order to activate this feature.

This tone is also generated with a stuck Control Head transfer button. Refer to Section B7 - STUCK TRANSFER BUTTON.

B5-2 Clutch Solenoid Control System Tones

B5-2.1 One Long - One Short Tone



This tone indicates that there is some type of malfunction with one or more of the Clutch or Neutral Solenoid Circuits. The exact nature of the malfunction can be further isolated as indicated by the Error Message on the Processor Display.

There are six (6) different Error Messages, which one or more will be displayed in conjunction with this tone depending on which solenoid and whether an Open or a short is detected. Error Messages 1 - 6 will be shown.

The System's program/memory must be told of the existence of these solenoids in order to activate this feature. Refer to Section 5 - SET UP PROCEDURES for Function **H2**.



B6 TROUBLESHOOTING REMOTE STATIONS

B6-1 Transfer

In order to transfer command from one Remote Station to another, the following must occur:

- There must be a valid "Command Signal" at the Station being transferred to.
- The "Command Signal" must indicate that the Control Head's lever(s) is at the Neutral/Idle position.
- The Transfer Button must be depressed which takes the "Station Select" signal from 5.00 VDC to 0.00 VDC.

If a transfer from one Remote Station to another is requested, but does not take place; the items required for successful transfer can be tested as follows:

B6-2 Command Signal

- The Command Signal is a DC voltage which varies in relationship to the Control Head's lever position.
- The Processor provides each Control Head 5.00 +/- 0.20VDC, which is referred to as the "Reference Voltage".
- The Reference Voltage is applied to a 5K Ohm Potentiometer in the Control Head.
- The potentiometer's "Wiper" taps off a portion of the Reference Voltage and sends it back to the Processor.
- The amount of DC voltage which is tapped off, is dependant on the position of the Control Head's lever.
- When the lever is fully Astern, a small portion of the Reference Voltage is tapped off by the wiper, and therefore, the voltage is at its lowest point (approximately 0.60 VDC).
- When the lever is positioned fully Ahead, a larger portion is tapped off and the voltage is at its highest point (approximately 4.40 VDC).

B6-3 A to D Counts

Since all the calculations within the control system are performed digitally, these DC voltages are expressed as and converted to a digital representation.

- The "Reference Voltage" (approximately 5.00 VDC) by which all analog inputs are based, is represented as 1023 A/D (Analog to Digital) Counts.
- This allows for the possibility of a 1024 possible positions when 0 is included in the count.
- The value of the Command Signal with the lever at the Neutral/Idle position is 48 - 50% of the Reference Voltage or 491 - 511 A/D's (2.40 - 2.50VDC).
- The Command Signal at Full Ahead is 83 - 85% of the Reference Voltage or 849 - 869 A/D's (4.15 - 4.25VDC).
- The Command Signal at Full Astern is 12 - 14% of the Reference Voltage or 123 - 143 A/D's (-.60 - 0.70VDC).



B6-4 Remote Station Select

The second required item for taking command is "Station Select" or depressing of the Transfer Button.

The Transfer Button can be tested by entering the Diagnostic Menu **H0**.

Figure 11: Display Station A/D's No Station Transfer Button Depressed

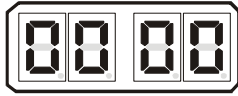

A) Depress the Up or Down (scroll) Push Button until four zeroes are displayed without decimal points as shown in Figure 11:.

Figure 12: Example Display Station A/D's Transfer Button Depressed for Stations 1 - 4

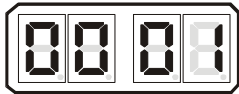

B) For Stations 1 - 4 when the Transfer Button is depressed, the 0 which represents that remote station, will change to a 1 as shown in Figure 12:.

Whenever command cannot be gained at a particular remote station, the Station Select and Command Signals are the first to be investigated. If either the Command Signal is out of range or the Station Select is inoperable, command will not be accepted at that remote station

B6-5 Stuck Transfer Button

The Transfer Button is a normally open, momentary switch. The only time the switch should close is when it is depressed to take command or when entering or departing various other functions. In the event that the Transfer Button became stuck in the closed position, the following will occur:

- The Transfer Button would have to be closed for 15 seconds or more.
- The throttle and clutch are not affected.
- A solid tone is heard from all remote stations, until the button's contact opens or transfer to another remote station has taken place.

If a Control Head that is not in command has a stuck transfer button, the following will happen:

- If Control Head levers are positioned at Neutral/Idle, a solid tone is heard from all remote stations.
- If Control Head levers are positioned other than Neutral/Idle, a three (3) second tone is heard from all remote stations.
- Error Code **29 - 32**, depending on which remote station, will be shown on the Processor Display.
- Command can be taken at any other operational remote station.
- After one (1) second command can be regained at the remote station with the stuck button as long as the problem has been corrected by depressing the transfer button.

If a stuck Transfer Button is suspected, this can be verified by looking at the Station Select status (**1** or **0**) as outlined in Section B6-4 - "Remote Station Select".

- An Error Code **29 - 32** will be shown on the Display, depending on which Station is experiencing the problem.



B7 TROUBLESHOOTING ERROR CODES

As stated previously, if a problem with the Control System is detected, the Processor is programmed to display numerous Error Codes to aid in the isolation of the cause. The following tables list these Error Codes, along with a brief description.

Table 2: Solenoid Clutch Error Codes

Error #	Title	Description
1	Clutch Astern Shorted	The Astern Clutch Solenoid is requiring more current than expected.
3	Clutch Neutral Shorted	The Neutral Clutch Solenoid is requiring more current than expected.
5	Clutch Ahead Shorted	The Ahead Clutch Solenoid is requiring more current than expected.

Table 3: Solenoid Troll Error Codes

Error #	Title	Description
7	Troll ON/OFF Shorted	The Troll ON/OFF Solenoid is requiring more current than expected.
9	Troll Command Shorted	The Troll Proportional Solenoid is requiring more current than expected.
10	Troll Command Open	The Troll Proportional Solenoid should be drawing current but is not.

Table 4: Basic Error Codes

Error #	Title	Description
13	Station No.1 Faulted High	Station No.1 Control Head's lever position is out of range. The input appears to be too high.
14	Station No.2 Faulted High	Station No.2 Control Head's lever position is out of range. The input appears to be too high.
15	Station No.3 Faulted High	Station No.3 Control Head's lever position is out of range. The input appears to be too high.
16	Station No.4 Faulted High	Station No.4 Control Head's lever position is out of range. The input appears to be too high.
17	Station No.5 Faulted High	Station No.5 Control Head's lever position is out of range. The input appears to be too high.
18	Station No.6 Faulted High	Station No.6 Control Head's lever position is out of range. The input appears to be too high.
19	Station No.7 Faulted High	Station No.7 Control Head's lever position is out of range. The input appears to be too high.
20	Station No.8 Faulted High	Station No.8 Control Head's lever position is out of range. The input appears to be too high.
21	Station No.1 Faulted Low	Station No.1 Control Head's lever position is out of range. The input appears to be too low.
22	Station No.2 Faulted Low	Station No.2 Control Head's lever position is out of range. The input appears to be too low.
23	Station No.3 Faulted Low	Station No.3 Control Head's lever position is out of range. The input appears to be too low.
24	Station No.4 Faulted Low	Station No.4 Control Head's lever position is out of range. The input appears to be too low.



25	Station No.5 Faulted Low	Station No.5 Control Head's lever position is out of range. The input appears to be too low.
26	Station No.6 Faulted Low	Station No.6 Control Head's lever position is out of range. The input appears to be too low.
27	Station No.7 Faulted Low	Station No.7 Control Head's lever position is out of range. The input appears to be too low.
28	Station No.8 Faulted Low	Station No.8 Control Head's lever position is out of range. The input appears to be too low.
29	Station No.1 Button Stuck Closed	Station No.1 Control Head's Transfer Button has either been closed too long or has been closed since power-up.
30	Station No.2 Button Stuck Closed	Station No.2 Control Head's Transfer Button has either been closed too long or has been closed since power-up.
31	Station No.3 Button Stuck Closed	Station No.3 Control Head's Transfer Button has either been closed too long or has been closed since power-up.
32	Station No.4 Button Stuck Closed	Station No.4 Control Head's Transfer Button has either been closed too long or has been closed since power-up.
33	Station No.5 Button Stuck Closed	Station No.5 Control Head's Transfer Button has either been closed too long or has been closed since power-up.
34	Station No.6 Button Stuck Closed	Station No.6 Control Head's Transfer Button has either been closed too long or has been closed since power-up.
35	Station No.7 Button Stuck Closed	Station No.7 Control Head's Transfer Button has either been closed too long or has been closed since power-up.
36	Station No.8 Button Stuck Closed	Station No.8 Control Head's Transfer Button has either been closed too long or has been closed since power-up.
37	CAN Communication Stuffing Error	The Control-Area-Network protocol has detected an error in communication with other devices on the network. The error type is a stuffing error.
38	CAN Communication Form Error	The Control-Area-Network protocol has detected an error in communication with other devices on the network. The error type is a form error.
39	CAN Communication Acknowledge Error	The Control-Area-Network protocol has detected an error in communication with other devices on the network. The error type is an acknowledge error.
40	CAN Communication Bit 1 Error	The Control-Area-Network protocol has detected an error in communication with other devices on the network. The error type is a Bit 1 error.
41	CAN Communication Bit 0 Error	The Control-Area-Network protocol has detected an error in communication with other devices on the network. The error type is a Bit 0 error.
42	CAN Communication CRC Error	The Control-Area-Network protocol has detected an error in communication with other devices on the network. The error type is a CRC error.
43	CAN Communication Bus Error	The Control-Area-Network protocol has detected an error in communication with other devices on the network. The error type is a Bus failure error. The error cannot be recovered from without cycling power to the Processor.
44	Comm. Error Time-out System 1	Communication with System has been too long without a Refresh message
45	Comm. Error Time-out System 2	Communication with System has been too long without a Refresh message
46	Comm. Error Time-out System 3	Communication with System has been too long without a Refresh message
47	Comm. Error Time-out System 4	Communication with System has been too long without a Refresh message



48	Comm. Error Time-out System 5	Communication with System has been too long without a Refresh message
49	Station Expander Comm. Error Time-out System 6	Communication with Station Expander has been too long without a Refresh message.
50	Station Expander Comm. Error Time-out System 7	Communication with Station Expander has been too long without a Refresh message.
51	Station Expander Comm. Error Time-out System 8	Communication with Station Expander has been too long without a Refresh message.
52	Station Expander Comm. Error Time-out System 9	Communication with Station Expander has been too long without a Refresh message.
53	Station Expander Comm. Error Time-out System 10	Communication with Station Expander has been too long without a Refresh message.
54	Over Voltage Fault	The applied battery voltage is above the expected limits for greater than two (2) seconds
55	Under Voltage Fault	The applied battery voltage is below the expected limits for greater than two (2) seconds
56	Reset Due to Software Watchdog	The system has had an unexpected Reset, due to a software problem.
57	Reset Due to Software Fault	The system has had an unexpected Reset, due to a software problem.
58	Reset Due to Hardware Watchdog	The system has had an unexpected Reset, due to a hardware problem.
59	Oscillator Watchdog	The system Oscillator has experienced a malfunction.



B8 TROUBLESHOOTING BASIC PROBLEM CAUSES AND SOLUTIONS

The following table lists the various Error Codes and provides possible causes and solutions. Error Codes appearing on the Port side Processor's Display LED are port side errors and vice versa. The Causes and Solutions provided are the most likely, but are not the only possible causes for the Errors Codes listed.

Table 5: Solenoid Clutch Problem Causes and Solutions

Error #	CAUSE		SOLUTION	
1	a.	The Astern Clutch Solenoid is defective.	a.	Replace the Astern Clutch Solenoid.
	b.	The Clutch Harness is incorrectly wired at the Gear Box.	b.	Properly connect the Clutch Harness to the Astern Solenoid.
2	a.	The Astern Clutch Solenoid circuit is Open.	a.	Properly connect the Astern Clutch Solenoid.
	b.	The Astern Clutch Solenoid is defective.	b.	Replace the Astern Clutch Solenoid.
3	a.	The Neutral Solenoid is defective.	a.	Replace the Neutral Solenoid.
	b.	The Neutral Solenoid is incorrectly wired at the Gear Box.	b.	Properly connect the Neutral Solenoid.
4	a.	The Neutral Solenoid circuit is Open.	a.	Properly connect the Neutral Solenoid.
	b.	The Neutral Solenoid is defective.	b.	Replace the Neutral Solenoid.
5	a.	The Ahead Clutch Solenoid Circuit is incorrectly wired at the Gear Box.	a.	Properly connect the Ahead Clutch Solenoid.
	b.	The Ahead Clutch Solenoid is defective.	b.	Replace the Ahead Clutch Solenoid.
6	a.	The Ahead Clutch Solenoid Circuit is Open.	a.	Properly connect the Ahead Clutch Solenoid.
	b.	The Ahead Clutch Solenoid is defective.	b.	Replace the Ahead Clutch Solenoid.

Table 6: Solenoid Troll Problem Causes and Solutions

Error #	CAUSE		SOLUTION	
7	a.	The Troll On/ Off Solenoid is defective.	a.	Properly connect the Troll On/ Off Solenoid.
	b.	The Troll On/ Off Solenoid is incorrectly wired at the Gear Box.	b.	Replace the Troll On/ Off Solenoid.
8	a.	The Troll On/ Off Solenoid circuit is Open.	a.	Properly connect the Troll On/ Off Solenoid.
	b.	The Troll On/ Off Solenoid is defective.	b.	Replace the Troll On/ Off Solenoid.
9	a.	The Troll Command Solenoid is defective.	a.	Properly connect the Troll Command Solenoid.
	b.	The Troll Command Solenoid is incorrectly wired at the Gear Box.	b.	Replace the Troll Command Solenoid.
10	a.	The Troll On/ Off Solenoid circuit is Open.	a.	Properly connect the Troll On/ Off Solenoid.
	b.	The Troll On/ Off Solenoid is defective.	b.	Replace the Troll On/ Off Solenoid.

Table 7: Basic Control System Problem Causes and Solutions

Error #	CAUSE		SOLUTION	
13	a.	The Station No.1 Control Head is defective.	a.	Replace Station No.1 Control Head.
14	a.	The Station No.2 Control Head is defective.	a.	Replace Station No.2 Control Head.
15	a.	The Station No.3 Control Head is defective.	a.	Replace Station No.3 Control Head.



16	a.	The Station No.4 Control Head is defective.	a.	Replace Station No.4 Control Head.
17	a.	The Station No.5 Control Head is defective.	a.	Replace Station No.5 Control Head.
18	a.	The Station No.6 Control Head is defective.	a.	Replace Station No.6 Control Head.
19	a.	The Station No.7 Control Head is defective.	a.	Replace Station No.7 Control Head.
20	a.	The Station No.8 Control Head is defective.	a.	Replace Station No.8 Control Head.
21	a.	The Station No.1 Control Head is not properly connected.	a	Properly connect the Station No.1 Control Head.
	b.	The Station No.1 Control Head is defective.	b	Replace Station No.1 Control Head.
22	a.	The Station No.2 Control Head is not properly connected.	a	Properly connect the Station No.2 Control Head.
	b.	The Station No.2 Control Head is defective.	b	Replace Station No.2 Control Head.
23	a.	The Station No.3 Control Head is not properly connected.	a	Properly connect the Station No.3 Control Head.
	b.	The Station No.3 Control Head is defective.	b	Replace Station No.3 Control Head.
24	a.	The Station No.4 Control Head is not properly connected.	a	Properly connect the Station No.4 Control Head.
	b.	The Station No.4 Control Head is defective.	b	Replace Station No.4 Control Head.
25	a.	The Station No.5 Control Head is not properly connected.	a	Properly connect the Station No.5 Control Head.
	b.	The Station No.5 Control Head is defective.	b	Replace Station No.5 Control Head.
26	a.	The Station No.6 Control Head is not properly connected.	a	Properly connect the Station No.6 Control Head.
	b.	The Station No.6 Control Head is defective.	b	Replace Station No.6 Control Head.
27	a.	The Station No.7 Control Head is not properly connected.	a	Properly connect the Station No.7 Control Head.
	b.	The Station No.7 Control Head is defective.	b	Replace Station No.7 Control Head.
28	a.	The Station No.8 Control Head is not properly connected.	a	Properly connect the Station No.8 Control Head.
	b.	The Station No.8 Control Head is defective.	b	Replace Station No.8 Control Head.
29	a.	The Station No.1 Control Head transfer button is defective	a.	Replace the Control Head
	b.	The Station No.1 Control Head is improperly wired.	b.	Properly connect Control Head
30	a.	The Station No.2 Control Head transfer button is defective	a.	Replace the Control Head
	b.	The Station No.2 Control Head is improperly wired.	b.	Properly connect Control Head
31	a.	The Station No.3 Control Head transfer button is defective	a.	Replace the Control Head
	b.	The Station No.3 Control Head is improperly wired.	b.	Properly connect Control Head
32	a.	The Station No.4 Control Head transfer button is defective	a.	Replace the Control Head
	b.	The Station No.4 Control Head is improperly wired.	b.	Properly connect Control Head
33	a.	The Station No.5 Control Head transfer button is defective	a.	Replace the Control Head
	b.	The Station No.5 Control Head is improperly wired.	b.	Properly connect Control Head



34	a.	The Station No.6 Control Head transfer button is defective	a.	Replace the Control Head
	b.	The Station No.6 Control Head is improperly wired.	b.	Properly connect Control Head
35	a.	The Station No.7 Control Head transfer button is defective	a.	Replace the Control Head
	b.	The Station No.7 Control Head is improperly wired.	b.	Properly connect Control Head
36	a.	The Station No.8 Control Head transfer button is defective	a.	Replace the Control Head
	b.	The Station No.8 Control Head is improperly wired.	b.	Properly connect Control Head
37	a.	The Serial Harness is in excess of 130 feet (40m).	a.	Reposition the Processor(s) so that the Serial Harness is less than 120 feet (37m).
	b.	The Processor is defective.	b.	Replace the faulty Processor.
	c.	The Serial Harness's shield is not properly terminated.	c.	Ensure that the shield is terminated and the termination is at one side only.
38	a.	The Serial Harness is in excess of 130 feet (40m).	a.	Reposition the Processor(s) so that the Serial Harness is less than 120 feet (37m).
	b.	The Processor is defective.	b.	Replace the faulty Processor.
	c.		c.	Ensure that the shield is terminated and the termination is at one side only.
39	a.	The Serial Harness is not connected at one or more Processors.	a.	Ensure that the Serial Harness is properly seated at all Processors.
	b.	The Serial Harness is incorrectly wired.	b.	Refer to the Serial Plug pin-out in Appendix B. Correct or replace the Harness.
	c.	Loss of power to one of the Processor.	c.	Restore Power to the Processor.
40	a.	The Serial Harness is in excess of 130 feet (40m).	a.	Reposition the Processor(s) so that the Serial Harness is less than 120 feet (37m).
	b.	The Processor is defective.	b.	Replace the faulty Processor.
	c.	The Serial Harness's shield is not properly terminated.	c.	Ensure that the shield is terminated and the termination is at one side only.
41	a.	The Serial Harness is in excess of 130 feet (40m).	a.	Reposition the Processor(s) so that the Serial Harness is less than 120 feet (37m).
	b.	The Processor is defective.	b.	Replace the faulty Processor.
	c.	The Serial Harness's shield is not properly terminated	c.	Ensure that the shield is terminated and the termination is at one side only.
42	a.	The Serial Harness is in excess of 130 feet (40m).	a.	Reposition the Processor(s) so that the Serial Harness is less than 120 feet (37m).
	b.	The Processor is defective.	b.	Replace the faulty Processor.
	c.	The Serial Harness's shield is not properly terminated.	c.	Ensure that the shield is terminated and the termination is at one side only.
43	a.	The Serial Harness is in excess of 130 feet (40m).	a.	Reposition the Processor(s) so that the Serial Harness is less than 120 feet (37m).
	b.	The Processor is defective.	b.	Replace the faulty Processor.
	c.	The Serial Harness's shield is not properly terminated.	c.	Ensure that the shield is terminated and the termination is at one side only.



44	a.	The Serial Harness is not connected at Processor ID No.1.	a.	Connect the Serial Harness into Processor ID No.1.
	b.	None of the Processors has ID No. 1 selected.	b.	Identify one of the Processors as ID No.1 with the A0 function.
	c.	Loss of power to Processor ID No.1.	c.	Restore power to Processor ID No.1.
45	a.	The Serial Harness is not connected at Processor ID No.2.	a.	Connect the Serial Harness into Processor ID No.2.
	b.	None of the Processors has ID No.2 selected.	b.	Identify one of the Processors as ID No.2 with the A0 function.
	c.	Loss of power to Processor ID No.2	c.	Restore power to Processor ID No.2.
	d.	Twin Screw System: One Processor has A1 set 01 (single screw) selected and the other Processor has A1 set 02 (twin screw).	d.	Set Up A1 to 02 (twin screw) on both Processors.
46	a.	The Serial Harness is not connected at Processor ID No.3.	a.	Connect the Serial Harness into Processor ID No.3.
	b.	None of the Processors has ID No.3 selected.	b.	Identify one of the Processors as ID No.3 with the A0 function.
	c.	Loss of power to Processor ID No.3.	c.	Restore power to Processor ID No.3.
47	a.	The Serial Harness is not connected at Processor ID No.4.	a.	Connect the Serial Harness into Processor ID No.4.
	b.	None of the Processors has ID No.4 selected.	b.	Identify one of the Processors as ID No.4 with the A0 function.
	c.	Loss of power to Processor ID No.4.	c.	Restore power to Processor ID No.4.
48	a.	The Serial Harness is not connected at Processor ID No.5.	a.	Connect the Serial Harness into Processor ID No.5.
	b.	None of the Processors has ID No.5 selected.	b.	Identify one of the Processors as ID No.5 with the A0 function.
	c.	Loss of power to Processor ID No.5.	c.	Restore power to Processor ID No.5.
49	a.	The Station Expander Serial Harness is not connected to ID #6, although it has been selected.	a.	Connect the Station Expander serial Harness into ID #6.
	b.	If six items had been selected, ID #6 has not been identified.	b.	Identify one item as ID #6 with the A0 Function.
	c.	Loss of power to ID#6.	c.	Restore power to ID#6.
50	a.	The Station Expander Serial Harness is not connected to ID #7, although it has been selected.	a.	Connect the Station Expander serial Harness into ID #7.
	b.	If six items had been selected, ID #7 has not been identified.	b.	Identify one item as ID #7 with the A0 Function.
	c.	Loss of power to ID#7	c.	Restore power to ID#7.
51	a.	The Station Expander Serial Harness is not connected to ID #8, although it has been selected.	a.	Connect the Station Expander serial Harness into ID #8.
	b.	If six items had been selected, ID #8 has not been identified.	b.	Identify one item as ID #8 with the A0 Function.
	c.	Loss of power to ID#8.	c.	Restore power to ID#8.



52	a.	The Station Expander Serial Harness is not connected to ID #9, although it has been selected.	a.	Connect the Station Expander serial Harness into ID #9.
	b.	If six items had been selected, ID #9 has not been identified.	b.	Identify one item as ID #9 with the A0 Function.
	c.	Loss of power to ID#9.	c.	Restore power to ID#9.
53	a.	The Station Expander Serial Harness is not connected to ID #10, although it has been selected.	a.	Connect the Station Expander serial Harness into ID #10.
	b.	If six items had been selected, ID #10 has not been identified.	b.	Identify one item as ID #10 with the A0 Function.
	c.	Loss of power to ID#10.	c.	Restore power to ID#10.
54	a.	The battery is being overcharged.	a.	Repair or replace the charging system.
	b.	There's a loose terminal on the battery while being charged.	b.	Clean and tighten the battery posts and terminals.
55	a.	Battery will not take a charge and is defective.	a.	Replace the battery.
	b.	The battery is not being properly charged	b.	Repair or replace the charging system.
	c.	There's a high resistance connection between the battery and the Processor.	c.	Locate and repair the high resistance connection
56		An unexpected software or hardware reset has occurred.		Replace the Processor.
57		An unexpected software reset has occurred.		Replace the Processor.
58		An unexpected software or hardware reset has occurred.		Replace the Processor.
59		External Interference, such as a lightning strike.		If the error message is displayed once and you are able to clear the error, take no further actions at this time. If the error cannot be cleared, replace the Processor.



B9 TROUBLESHOOTING PROBLEMS WITHOUT ERROR CODES

In addition to the Error Codes listed above, some problems may not necessarily generate Error Codes. The following give some examples where the Processor may not detect a fault, though the operation may not be perfect:

B9-1 Basic Control System Problems Without Error Codes

SYMPTOM:	CAUSE		REMEDY
No audible tones heard at one Control Station when power is first applied to the Processor. All other features function normally.	a.	Incorrectly wired Station Harness/ Cable.	a. Verify that the black wire is properly connected to pin 1 on the Control Head and Pin 8 at the Processor.
	b.	The Control Head's Sound Transducer is defective.	b. Measure the AC voltage at pins 1 & 3 of the Control Head. If 20- 25 VAC is present, replace the Control Head.
SYMPTOM	CAUSE		REMEDY
The Control Head's red LED doesn't light when in command, but otherwise functions properly	a.	Incorrectly wired Station Harness/ Cable.	a. Verify that the brown wire is properly connected to pin 2 on the Control head and pin 2 at the Processor.
	b.	The Control Head's red LED or circuit is open.	b. Measure the DC voltage at pins 2 & 3 at the Control Head. The measurement will be approximately 2.20 VDC when the red LED is lit. If 4.00 VDC is measured, the red LED or its circuit is open. Replace the Control Head.
SYMPTOM	CAUSE		REMEDY
The engine begins to turn-over while starting and then stops. A slow repetitive tone is heard from all Remote Stations	a.	The voltage available at the Processor has dropped too low, due to the starter's current requirement	a. Supply power to the Processor from a battery other than the starting battery or supply power from two sources through an APS (Automatic Power Selector).
	b.	Battery charge is too low	b. Recharge/ replace the battery or supply battery power from two sources through an APS.
SYMPTOM	CAUSE		REMEDY
When power is turned ON to the Processor, there are no tones from any of the Remote Stations, the Control Head red LED does not light when the Transfer Button is pressed, and the Display is not lit at the Processor.	a.	No power to the Processor.	a. Disconnect the Power Harness from the Processor. Measure the DC voltage at pins 10 (+) and 11 (-) of the Harness plug. If 12 or 24 VDC is not present, check the circuit breakers, switches and cables feeding power to the Processor. Correct the power source as required.
	b.	The battery's polarity is reversed at the Processor.	b. Disconnect the Power Harness from the Processor. Connect a voltmeter's red lead to pin 10 and the black lead to pin 11 of the Harness's plug. If negative voltage is measured, reverse the wires.
	c.	Defective Processor.	c. If Causes a. and b. were not the fault, replace the Processor.



SYMPTOM	CAUSE		REMEDY
<p>Active Synchronization is Inoperable.</p>	<p>a. There is no Tachometer Sensor signal at the Port or Starboard Processor.</p>	<p>a. The Tachometer Sensor frequency can be seen on the Processor's Display by accessing the Diagnostic Menu H0. If the frequency is not measured, check the Tachometer Sensor and the wiring.</p>	
	<p>b. Loss of Serial Communication between the Processors.</p>	<p>b. If Active Synchronization is inoperative due to a lack of Serial Communications, one or more Error Codes will be displayed indicating the loss of communication.</p>	
	<p>c. The Processor's Identification number(s) have not been set properly.</p>	<p>c. All Processors must have a unique identification number as set with Function Code A0. Refer to Section 5- SET UP PROCEDURES.</p>	
	<p>d. The correct number of engines has not been set.</p>	<p>d. All Processor must have the same number of engines selected as programmed with Function Code A1. Refer to Section 5- SET UP PROCEDURES.</p>	

SYMPTOM	CAUSE		REMEDY
<p>When transferring command from one Station to another, command transfers to one side only. No Error Messages are displayed.</p>	<p>The Control Head Harnesses are plugged into two different Station connectors on a Processor with the Software Revision .0</p>		<p>Set the correct Throttle Profile with Function Code E0. Refer to Section 5 - SET UP PRODCEDURES. Plug the Control Head Harnesses into the same numbered Station connector on the Port and Starboard Processors</p>

SYMPTOM	CAUSE		REMEDY
<p>When transferring command from one Station to another, the transfer does not take place. The red LED does not light, even temporarily. No Error Messages are displayed.</p>	<p>a. The Control Head Harnesses are plugged into two different Station connectors on a Processor with the Software Revision .1</p>	<p>a. Set the correct Throttle Profile with Function Code E0. Refer to Section 5 - SET UP PRODCEDURES.</p>	
	<p>b. The Transfer Button is defective.</p>	<p>b. Verify a defective Transfer Button by accessing the H0 Diagnostic Menu. If the 0 does not change to a 1 while the Transfer Button is depressed, replace the Control Head.</p>	



B9-2 Solenoid Clutch Problems Without Error Codes

SYMPTOM	CAUSE	REMEDY
Cannot obtain Warm-up Mode while moving the Control Head lever in the Ahead direction, only in the Astern direction.	The Processor is sensing that the Control Head's lever is moving in the Astern direction	Depress the Transfer Button while moving the Control Head lever in the Astern direction. If the LED begins to blink, the Control Head is incorrectly wired. *** Check the colors of the wires at pins 5 and 7. *** A <u>right hand</u> Control Head should have yellow at pin 5 and blue at pin 7. *** A <u>left hand</u> Control Head should have blue at pin 5 and yellow at pin 7. *** Ahead and Astern Solenoid Wires need to be reversed.

B9-3 Electronic Throttle Problems Without Error Codes

SYMPTOM	CAUSE	REMEDY
The engine RPM's vary, without moving the Control Head lever (synchronization disabled).	a. Problem with the Governor.	a. Connect the Break-out Box (p/n 13927) as shown in the Throttle Testing Section of the Service Field Test Unit Manual. <u>If variations are seen</u> , proceed to Step b). <u>If no variations are seen</u> , contact a certified engine mechanic.
	b. Erratic Command Signal.	b. Refer to Command Signal testing in Section B6 - STATION TRANSFER. If variations of the A/D counts occur, connect the Control Head to another Station (if available) on the Processor. If variations persist, replace the Control Head.

SYMPTOM	CAUSE	REMEDY
The engine's Idle and Full Throttle RPM's are too high or too low.	a. The incorrect Throttle Profile has been set.	a. Set the correct Throttle Profile with Function Code E0. Refer to Section 5 - SET UP PROCEDURES.
	b. The Idle (Function Code E2 Throttle Minimum) and Full Throttle (Function Code E3 Throttle Maximum) are incorrectly set.	b. Adjust Throttle Minimum E2 and Throttle Maximum E3 as specified in Section 6 - DOCK TRIALS.
	c. The Governor or its Control Module is incorrectly adjusted or faulty.	c. After Causes a. and b. have been eliminated, contact a certified engine mechanic to properly adjust.



B10 SYNCHRONIZATION TROUBLESHOOTING

If you encounter a problem with Synchronization, it will more than likely one of the following; failure to attempt to synchronize, synchronizing at different RPM's or RPM variations of one or both engines while synchronized. Each problem is distinct and the cause may differ depending on the type of Synch. Therefore, each type is discussed individually.

B10-1 Equal Throttle Synchronization

B10-1.1 Basic Troubleshooting

SYMPTOM	CAUSE		SOLUTION
Will not synchronize.	a.	Synchronization is Disabled	a. At the Station-in-Command, move both Control Head levers to more than 5% of the speed range. Press and hold the transfer button for 5 seconds. If synch is disabled, the green LED will light as long as the button is pressed. If synch was enabled, the green LED would have blinked twice.
	b.	The Serial Communication Harness is not plugged into both Processors.	b. Plug the Serial Communication Harness into both Processors.
	c.	The Port and Starboard Processors are not set up for Twin Screw operation.	c. Plug the Serial Communication Harness into both Processors.
	d.	The Port and Starboard Processors have the same ID number.	d. On the Port Processor, scroll to Function A0 and enter a Value of 01. On the Starboard Processor, scroll to Function A0 and enter a Value of 02.

B10-2 Active Synchronization

B10-2.1 Basic Troubleshooting

SYMPTOM	CAUSE	SOLUTION
The green LED is lit solid, though the Engine RPM's differ by a significant amount.	The Tach Sender signal has been lost by one or both Processors.	Scroll to Function Code H0. Go to the Value for the Tach Sender's input frequency. If the frequency displayed is 0000, the signal has been lost and the system diverted to Equal Throttle Synch. Correct the wiring or replace the Sender.



SYMPTOM	CAUSE		SOLUTION
Will not synchronize.	a.	Synchronization is Disabled	a. At the Station-in-Command, move both Control Head levers to more than 5% of the speed range. Press and hold the transfer button for 5 seconds. If synch is disabled, the green LED will light as long as the button is pressed. If synch was enabled, the green LED would have blinked twice.
	b.	The Serial Communication Harness is not plugged into both Processors.	b. Plug the Serial Communication Harness into both Processors.
	c.	The Port and Starboard Processors have the same ID number.	c. On the Port Processor, scroll to Function Code A0 and enter a Value of 01. On the Starboard Processor, scroll to Function Code A0 and enter a Value of 02.
	d.	The Port and Starboard Processors are not set up for twin screw operation	d. Scroll to Function Code A1, on the Port and Starboard Processor. Enter a Value of 02 into both Processors.

B10-2.2 Electronic Throttle

SYMPTOM	CAUSE		SOLUTION
The green LED is lit solid, though the Engine RPM's differ by a significant amount.	a.	Function Code E7 is set to 00 and the Throttle Minimum and Throttle Maximum Values differ between the Port and Starboard Processors.	a. Scroll to Function Codes E2 and E3 on both Processors and compare the Values. The Values of E2 and E3 must be the same for both Processors. Adjust as necessary.
	b.	The engines run at different RPM's with the same throttle command signals.	b. Active Synchronization MUST be Enabled.

SYMPTOM	CAUSE		SOLUTION
One or both of the engines continually changes RPM (hunts). Will not synchronize properly	a.	A Station-in-Command Control Head's Command Signal is varying	a. Scroll to the Diagnostic Menu Function Code H0. Go to the appropriate Station A/D Count's display. The Value should not change by more than +/- 1 A/D Count. If so, check the connections and if good, replace the Control Head.
	b.	One or both of the Tach Signals isn't being read, or is being read intermittently. Function Code E7 is set to a Value of 01 or 03.	b. Scroll to Function Code H0 on both Processors and display the frequency of the Tach Signal. If variations of the signal are measured, the cause must be determined



SYMPTOM	CAUSE		SOLUTION
<p>Synchronization does not function. The Control Head's green LED does not light.</p>	<p>a. The Processors think Astern is being commanded when the Control Head lever is positioned to the Ahead Detent.</p>	<p>a. Place both the Port and Starboard Processor into Warm-up Mode by pressing the Transfer Button while moving the Control Head levers to the Ahead detent. Both Control Head's red LEDs should be blinking. If not, the 7-conductor's connections at pins 5 and 7 are reversed.</p>	
	<p>b. The Serial Communication Harness is not properly installed.</p>	<p>b. Ensure the Serial Harness' plugs are fully inserted into the Port and Starboard Processor's Pigtails.</p>	
	<p>c. The Processors are not programmed for twin screw.</p>	<p>c. Scroll to Function Code A1 on both Processors and verify that the Value of both is set to 02.</p>	
	<p>d. Both Processors are set to the same ID number.</p>	<p>d. Scroll to Function Code A0 and verify that the Port and Starboard Processors have different ID numbers.</p>	
	<p>e. Function Code E7 Value is set to 02.</p>	<p>e. Depending on the installation, change the Value of E7 to 00, 01, or 03.</p>	
	<p>f. Function Code E7 is set to 03 and no Tach Signal is present.</p>	<p>f. Determine why there is no Tach Signal present.</p>	



1 TROUBLESHOOTING WIRE HARNESSSES

The following Sections list the various Harnesses manufactured for use with the Processor. These tables are invaluable when troubleshooting a suspected interface problem or when manufacturing your own Harnesses.

The Wire Harness Plug figures below indicators:

- SOLID BLACK circles wire termination
- MEDIUM GRAY circles variation in terminations (refer to Table for information)
- WHITE circles indicate no wire termination.

1-1 Basic Control System Harnesses

Table 8: Power, Start Interlock Harness Pin-Out

Plugs into Processor POWER Connector	HARNESS PLUG Termination A	HARNESS PLUG Conductor Color	ENGINE & BATTERY Termination B	ENGINE & BATTERY Description
	1	Yellow w/ Red Trace	Starter Solenoid	Closed contact when In-Command and at Neutral.
	10	Red	Battery (+)	+ 24 VDC
	11	Black	Battery (-)	- DC Return
	12	Yellow w/ Red Trace	Starter Switch Wire at the Starter Solenoid	Closed contact when In-Command and at Neutral.

Table 9: Power, Start Interlock , Clutch Pressure Switch Harness Pin-Out

Plugs into Processor POWER Connector	HARNESS Termination A	HARNESS Conductor Color	ENGINE/GEAR/BATTERY Termination B	ENGINE/GEAR/BATTERY Description
	1	Yellow w/ Red Trace	Starter Solenoid	Closed Contact when In-Command and at Neutral
	6	Light Blue	Clutch Pressure Switch	Normally Open contact that closes when transmission manufacturer's minimum safe operating pressure is reached.
	7	Light Blue	Clutch Pressure Switch	Normally Open contact that closes when transmission manufacturer's minimum safe operating pressure is reached.
	10	Red	Battery (+)	24 VDC
	11	Black	Battery (-)	- DC Return
	12	Yellow w/ Red Trace	Starter Switch Wire at the Starter Solenoid	Closed contact when In-Command and at Neutral

Table 10: Power, Start Interlock, Clutch Pressure Switch, and Alarm Harness Pin-Out

Plugs into Processor POWER Connector	HARNESS Termination A	HARNESS Conductor	ENGINE/GEAR/ALARM/ BATTERY Termination B	ENGINE/GEAR/ALARM/BATTERY Description
	1	Yellow w/ Red Trace	Start Solenoid	Closed Contact when In-Command and at Neutral
	2	Red	External Alarm Circuit	Normally Open contact opens with fault or loss of power.
	3	Black	External Alarm Circuit	Normally Open contact opens with fault or loss of power
	6	Light Blue	Clutch Pressure Switch	Normally Open contact that closes when transmission manufacturer's minimum safe operating pressure is reached.



Table 10: Power, Start Interlock, Clutch Pressure Switch, and Alarm Harness Pin-Out

Plugs into Processor POWER Connector	HARNESS Termination A	HARNESS Conductor	ENGINE/GEAR/ALARM/BATTERY Termination B	ENGINE/GEAR/ALARM/BATTERY Description
	7	Light Blue	Clutch Pressure Switch	Normally Open contact that closes when transmission manufacturer's minimum safe operating pressure is reached.
	10	Red	Battery (+)	+ 24 VDC
	11	Black	Battery (-)	- DC Return
	12	Yellow w/ Red Trace	Starter Switch Wire at the Starter Solenoid	Closed contact when In-Command and at Neutral

Table 11: Serial Communication Harness Pin-Out

Plugs into each Processor's SERIAL Connector	HARNESS PLUG Termination End A	HARNESS PLUG Conductor Color	HARNESS PLUG Termination End B	HARNESS PLUG Description
	1	Black	1	CAN Low
	2	Red	2	CAN High
	6	Yellow/Green	N/C	N/A

Table 12: Control Head Harness Pin-Out

Plugs into Processor STATION Connectors	Plugs into Control Head Pigtail Connector	Termination A	Conductor Color	Termination B	Description
		1	Green/Yellow	N/C	Shield
		2	Brown	2	Red LED (+)
		3	Violet	8 (Stbd side only)	Green LED (-)
		4	Orange	4	Transfer Button (+)
		5	Red	3	Ground
		6	Green	6	Lever Command Signal
		7	Blue	5 (left hand) 7 (right hand)	VREF/Reference Voltage
		8	Black	1	Tone (+)

Table 13: Control Head Harness Hard-Wire

Plugs into Processor STATION Connectors	Hard-wires to Control Head	Termination A	Conductor Color	Termination B	Description
		1	Green/Yellow	N/C	Shield
		2	Brown	2	Red LED (+)
		3	Violet	8	Green LED (-)
		4	Orange	4	Transfer Button (+)
		5	Red	3	Ground
		6	Green	6	Lever Command Signal
		7	Blue	5 (Port); 7 (Stbd)	VREF (+5VDC)
		8	Black	1	Tone (+)



NOTE: Starboard Side of Control Head - Jumper Pins 3 to 5;
Port Side of Control Head - Jumper Pins 3 to 7

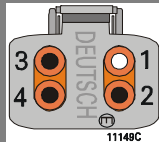

Table 14: Tachometer Sensor Harness Pin-Out

Plugs into Processor TACH Connector	Termination A	Conductor Color	TACH SENSOR Termination B	TACH SENSOR Description
Termination A 	2	Red	Pin B	Tachometer (+)
	3	Black	Pin C	Tachometer (-)
	4	Green/Yellow	N/C	N/A

B1-1 Clutch Harnesses

Table 15: Power/Ahead/Astern Clutch Harness Pin-Out

Plugs into Processor CLUTCH Connector	Termination A	Conductor Color	GEAR BOX Termination B	GEAR BOX Description
Termination Ay 	1	Red	+ DC Power Source	+ 24 VDC
	2	Black	- DC Power Source	- VDC Return
	3	Red	Ahead Solenoid	+ 24 VDC when Ahead Clutch Selected
	4	Black	Ahead Solenoid	- VDC Return for Ahead Clutch
	5	Red	Astern Solenoid	+ 24 VDC when Astern Clutch Selected
	6	Black	Astern Solenoid	- VDC Return for Astern Clutch

Table 16: PowerAhead/Neutral/Astern Clutch Harness Pin-Out

Plugs into Processor CLUTCH Connector	Termination A	Conductor Color	GEAR BOX Termination B	GEAR BOX Description
Termination A 	1	Red	+ DC Power Source	+ 24 VDC
	2	Black	- DC Power Source	- VDC Return
	3	Red	Ahead Solenoid	+ 24 VDC when Ahead Clutch Selected
	4	Black	Ahead Solenoid	- VDC Return for Ahead Clutch
	5	Red	Astern Solenoid	+ 24 VDC when Astern Clutch Selected
	6	Black	Astern Solenoid	- VDC Return for Astern Clutch
	7	Red	Neutral Solenoid	+24 VDC at all times
	8	Black	Neutral Solenoid	-VDC Return for Neutral Solenoid

B1-2 Clutch/Troll Harnesses

Table 17: Power/Ahead/Astern Clutch, Troll ON/OFF, and Troll Command Harness Pin-Out

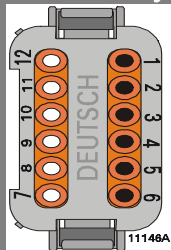
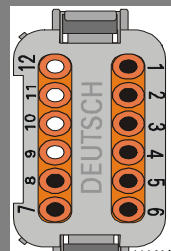
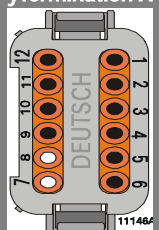
Plugs into Processor CLUTCH Connector	Termination A	Conductor Color	GEAR BOX Termination B	GEAR BOX Description
yTermination A 	1	Red	+ DC Power Source	+24 VDC
	2	Black	- DC Power Source	- VDC Return
	3	Red	Ahead Clutch Solenoid	+ 24 VDC when Ahead Clutch Selected
	4	Black	Ahead Clutch Solenoid	- VDC Return for Ahead Clutch
	5	Red	Astern Clutch Solenoid	+ 24 VDC when Astern Clutch Selected
	6	Black	Astern Clutch Solenoid	- VDC Return for Astern Clutch
	9	Red	Troll On/Off Solenoid	+24 VDC when Troll is selected.
	10	Black	Troll On/Off Solenoid	-VDC Return for Troll On/Off Solenoid
	11	Red	Troll Command Solenoid	0- 100% Duty Cycle @ 500Hz. for controlling Proportional Solenoid Valve
	12	Black	Troll Command Solenoid	-VDC Return for Troll Command Solenoid



B1-3 Throttle Harnesses

Table 18: Current/MAN Throttle Harness Pin-Out

Plugs into the Processor THROTTLE Connector	Termination A	Conductor Color	ENGINE Termination B	ENGINE Description
	1	Black	Engine DC-Bus	Throttle Signal Return
	3	Red	ECM	0.00 - 21.0 mA Throttle Signal
	8	Green/Yellow	N/C	N/A

Table 19: Frequency Throttle Harness Pin-Out

Plugs into Processor THROTTLE Connector	Termination A	Conductor Color	ENGINE Termination B	ENGINE Description
	1	Black	Engine DC-Bus	Throttle Signal Return
	7	Red	ECM	120.64 - 463.50 Hz Throttle Signal
	8	Green/Yellow	N/C	N/A

Table 20: PWM Throttle Harness Pin-Out

Plugs into Processor THROTTLE Connector	Termination A	Conductor Color	ENGINE Termination B	ENGINE Description
	1	Black	Engine DC-Bus	Throttle Signal Return
	2	Red	ECM	PWM Throttle Signal (0 - 100% Duty Cycle @ 500 Hz)
	8	Green/Yellow	N/C	N/A

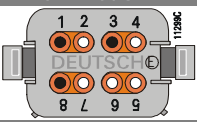
Table 21: Voltage Throttle Harness Pin-Out

Plug into Processor THROTTLE Connector	Termination A	Conductor Color	ENGINE Termination B	ENGINE Description
	1	Black	Engine DC-Bus	Throttle Signal Return
	4	Red	ECM	0.00 - 5.00 VDC Throttle Signal
	8	Green/Yellow	N/C	N/A

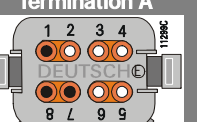
Service Field Test Unit

Reference Manual

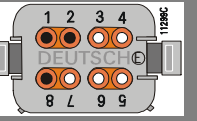
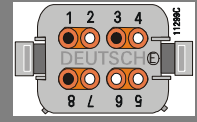
MM13927 Rev.D 10/03

MM13927 Table of Contents

MM13927 Table of Contents	TOC-1
Revision List	TOC-2

1 INTRODUCTION - - - - - 1-1

Figure 1-1: Service Field Test Unit (Break-out Box)	1-1
Figure 1-2: CruiseCommand Connector Locations	1-1
Figure 1-3: Example of ClearCommand Pigtail Locations	1-1
Table 1-1: Connector/Pigtail Descriptions	1-1

2 PROCEDURE - - - - - 2-1

2-1 Throttle Signal Testing	2-1
2-1.1 DC Voltage	2-1
Figure 2-4: Throttle Connection (DC Voltage)	2-1
2-1.2 Current (mA)	2-1
Figure 2-5: Throttle Connection (Current mA)	2-2
2-1.3 PWM (Pulse Width Modulation) with DC Voltmeter	2-2
Figure 2-6: Throttle Connection (PWM with DC Voltmeter)	2-2
2-1.4 PWM (Pulse Width Modulation) with Duty Cycle Meter	2-3
Figure 2-7: Throttle Connection (PWM with Duty Cycle Meter)	2-3
2-1.5 Frequency (Hz.)	2-3
Figure 2-8: Throttle Connection (Frequency Hz)	2-3
2-2 CLUTCH TESTING	2-4
2-2.1 Neutral Solenoid Testing	2-4
Figure 2-9: Clutch Connection (Neutral Solenoid)	2-4
2-2.2 Ahead Solenoid Testing	2-4
Figure 2-10: Clutch Connection (Ahead Solenoid)	2-4
2-2.3 Astern Solenoid Testing	2-5
Figure 2-11: Clutch Connection (Astern Solenoid)	2-5
2-3 TROLL TESTING	2-6
2-3.1 Troll On/Off Solenoid	2-6
Figure 2-12: Troll Connection (ON/OFF Solenoid)	2-6
2-3.2 Troll Command (Proportional Solenoid) Testing with Amp Meter	2-6
Figure 2-13: Troll Connection (Proportional Solenoid with Amp Meter)	2-6
2-4 2-SPEED TESTING	2-8
2-4.1 2nd Gear Disengaged	2-8
Figure 2-14: 2-Speed Connection	2-8
2-4.2 2nd Gear Engaged	2-8

3 Parts List - - - - - 3-1

Table 3-2: Parts List	3-1
-----------------------------	-----

Revision List

Rev	Date	Revision Description
A	11/02	Revised Section 1.0 Table 1
B	2/03	Revised manual to current ZF Marine Electronics manual standards. Revised Section 3.0
C	4/03	Deleted Section 2.1.6
D	10/03	Revising to add 9000 Series and 2-Speed information



MM13927-1 INTRODUCTION

Figure 1: Service Field Test Unit (Break-out Box)

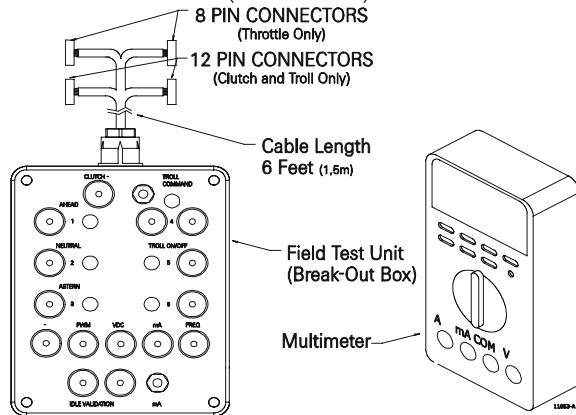

Refer to Bulletin 02-008 for Service Field Test Unit (Part No. 13927) recommendations.

Refer to Figure 1: for an example of the Test Unit and a Multimeter.

The Service Field Test Unit, hereafter referred to as the "Break-out Box", is recommended for use with all CruiseCommand Processors (Part No. 785CE) and with ClearCommand Processors (Part No. 9XXX Series) that have pluggable (Pigtail) Throttle, Clutch or Troll Connections.

The procedures for testing the various outputs of the ClearCommand and CruiseCommand Processors are similar, with the exception of where they connect to the respective Processor. Figure 2: indicates the location of the connectors on the CruiseCommand Processor and Figure 3: the typical pigtail plugs on a 9000 Series ClearCommand Processor.



NOTE: Not all ClearCommand Processors have all of the pigtails shown in Figure 3. Only the pigtails that are required for a specific application are installed in a ClearCommand Processor.

Figure 2: CruiseCommand Connector Locations

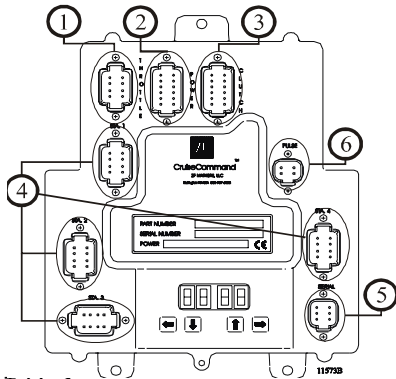

Figure 3: Example of ClearCommand Pigtail Locations

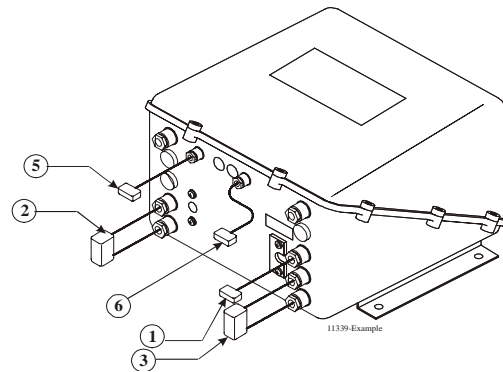

Table 1:

Designation #	Description	Harness Type	Harness Use
1	Black 8 Pin	Throttle Connector/ Pigtail	The throttle signal is output from this connector/pigtail. The signal may be in the form of Pulse Width Modulation (PWM), Voltage, Current, or Frequency
2	Black 12 Pin	Power Connector/Pigtail	This connector/pigtail contains the inputs and outputs for Main Processor Power, Start Interlock, Clutch Oil Pressure Interlock, and External Alarm Circuit.
3	Gray 12 Pin	Clutch Connector/ Pigtail	The external connections for Clutch Power, Ahead, Astern, and Neutral Solenoids, Troll On/ Off, and Proportional Solenoids are made at this connector/pigtail.
4	Gray 8 Pin	Control Head Connector	All the required connections for the Remote Control Stations are made at these connectors.
5	Gray 6 Pin	Serial Communication Connector/Pigtail	The Serial Communication connections between multiple Processors in applications with more than one Processor at this connector/pigtail
6	Gray 4 Pin	Tachometer Sensor Connector/Pigtail	The input signal from a Tachometer or Shaft Speed Sensor connects to this connector/pigtail.



MM13927-2 PROCEDURE

The actual procedures for using the Break-out Box are the same for CruiseCommand and ClearCommand Processors. However, the adjustment within the Processor to obtain the correct output may differ. The appropriate Installation Manual must be referred to when making the adjustments.

MM13927-2-1 Throttle Signal Testing

Depending on which Processor is being tested, it may have the capability of sourcing one or all of the following: DC Voltage, Current, PWM (Pulse Width Modulation) or Frequency.



NOTE: The following procedures and drawings pertain to both the CruiseCommand and ClearCommand Processors.

MM13927-2-1.1 DC Voltage

A) Ensure that power is removed from the Engine Electronics and the Processor.

Figure 4: Throttle Connection (DC Voltage)

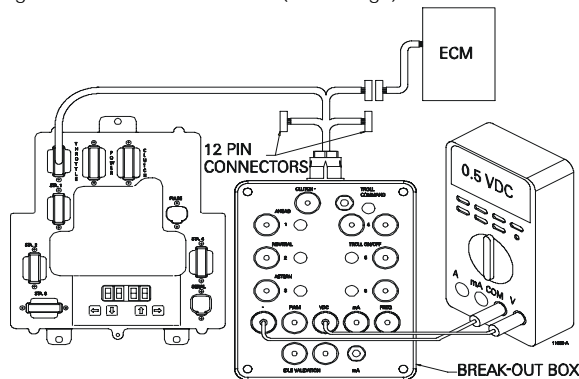

- B) Disconnect the Throttle Harness from the number 1 Processor connector/pigtail.
- C) Insert the Break-out Box between the number 1 Processor connector/pigtail and the Throttle Harness as shown in Figure 4:.
- D) Set up the Multimeter to measure DC Volts and plug the black lead into the Break-out Box black socket labeled “-” and the red lead into the socket labeled “VDC”.
- E) Turn power ‘On’ to the Processor and take command at any Remote Station.
- F) The appropriate Idle Voltage for the application should be measured at this time.

G) Move the Control Head lever to the Full Throttle position while depressing the Transfer Button (Throttle Only Mode).

H) The appropriate Full Throttle Voltage for the application should be measured at this time.

MM13927-2-1.2 Current (mA)

A) Ensure power is removed from both the Engine Electronics and the Processor.

B) Disconnect the Throttle Harness from the number 1 Processor connector/pigtail.

C) Insert the Break-out Box between the number 1 Processor connector/pigtail and the Throttle Harness as shown in Figure 5:.

Figure 5: Throttle Connection (Current mA)

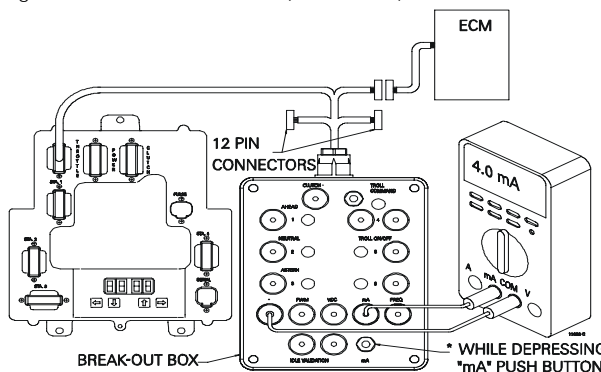

- D) Set up the Multimeter to measure current (mA.) and plug the black lead into the Break-out Box black socket labeled “-” and the red lead into the socket labeled “mA”.
- E) Turn power ‘On’ to the Processor and take command at any Remote Station.
- F) Depress and hold the Push-button Switch labeled “mA.” The appropriate Current (mA.) for the application should be measured.
- G) Move the Control Head lever to the Full Throttle position while depressing the Transfer Button (Throttle Only Mode).

H) Depress and hold the “mA.” Push-button. The appropriate Full Throttle Current (mA.) for the application should be measured at this time.

MM13927-2-1.3 PWM (Pulse Width Modulation) with DC Voltmeter

A) Ensure power is removed from both the Engine Electronics and the Processor.

B) Disconnect the Throttle Harness from the number 1 Processor connector/pigtail.



- C) Insert the Break-out Box between the number 1 Processor connector/pigtail and the Throttle Harness as shown in Figure 6: labeled "-" and the red lead into the socket labeled "PWM".

Figure 6: Throttle Connection (PWM with DC Voltmeter)

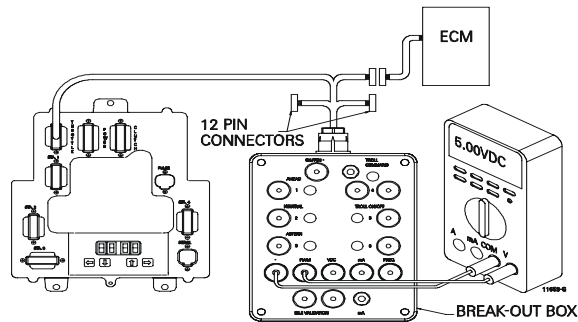

- D) Turn power 'On' to the Caterpillar ECM (Electronic Control Module) Only. Do Not apply power to the Processor at this time.
- E) Depending on the type of Caterpillar ECM (PEEC or ADEMS), the measurement should be approximately 5.00 or 12.00 VDC. Record the measurement as shown in Drawing Figure 6:.
- F) Set up the Multimeter to DC Volts and plug the black lead into the Break-out Box black socket Turn power 'On' to the Processor and take command at any Remote Station.
- G) Record the DC Voltage at this time. The measurement should be 7- 9% of the voltage measured in step F).
- H) Move the Control Head lever to the Full Throttle position while depressing the Transfer Button (Throttle Only Mode).
- I) The measurement should be 91- 93% of the voltage measured in step F) [e.g. Idle = 8% of 12 VDC reference or 0.96 VDC; Full Throttle = 92% of 12 VDC reference or 11.04 VDC.

MM13927-2-1.4 PWM (Pulse Width Modulation) with Duty Cycle Meter

- A) Ensure power is removed from both the Engine electronics and the Processor.

Figure 7: Throttle connection (PWM with Duty Cycle Meter)

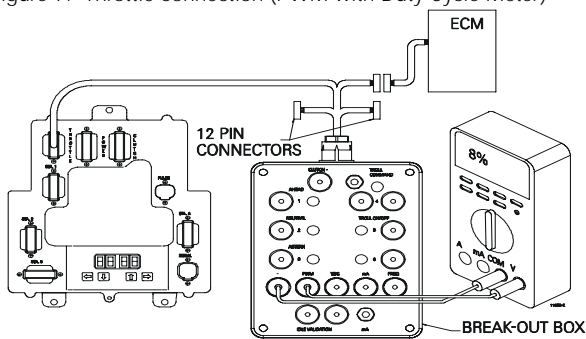

- B) Disconnect the Throttle Harness from the number 1 Processor connector/pigtail.
- C) Insert the Break-out Box between the number 1 Processor connector/pigtail and the Throttle Harness as shown in Figure 7:
- D) Set up the Multimeter to measure Duty Cycle and plug the black lead into the Break-out Box black socket labeled "-" and the red lead into the socket labeled "PWM".
- E) Turn power 'On' to the Caterpillar ECM (Electronic Control Module) and to the Processor.
- F) The measurement should be approximately 8% duty Cycle.
- G) Move the Control Head lever to the Full Throttle position while depressing the Transfer Button (Throttle Only Mode).
- H) The measurement will increase from 8% to 91- 93%.

MM13927-2-1.5 Frequency (Hz.)

Figure 8: Throttle Connection (Frequency Hz)

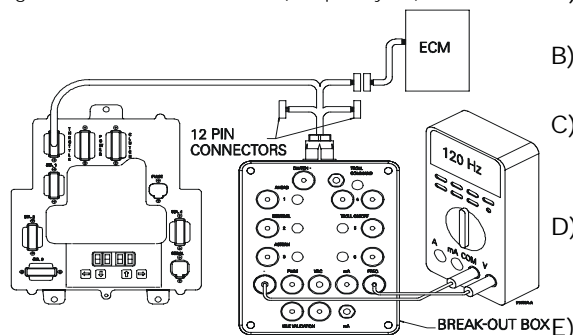

- A) Ensure power is removed from both the Engine Electronics and the Processor.
- B) Disconnect the Throttle Harness from the number 1 Processor connector/pigtail.
- C) Insert the Break-out Box between the number 1 Processor connector/pigtail and the Throttle Harness as shown in Figure 8:
- D) Set up the Multimeter to measure Frequency and plug the black lead into the Break-out Box black socket labeled "-" and the red lead into the socket labeled "FREQ".
- F) Turn power 'On' to the Processor and take command at any Remote Station.
- G) The appropriate Idle Frequency for the application should be measured at this time.
- H) Move the Control Head lever to the Full Throttle position while depressing the Transfer Button (Throttle Only Mode).
- I) The appropriate Full Throttle Frequency for the application should be measured at this time.



MM13927-3 CLUTCH PROCEDURE

MM13927-3-1 TESTING

MM13927-3-1.1 Neutral Solenoid Testing

- A) Ensure power is removed from both the Processor and the Clutch Power Supply.

Figure 9: Clutch Connections Neutral Solenoid

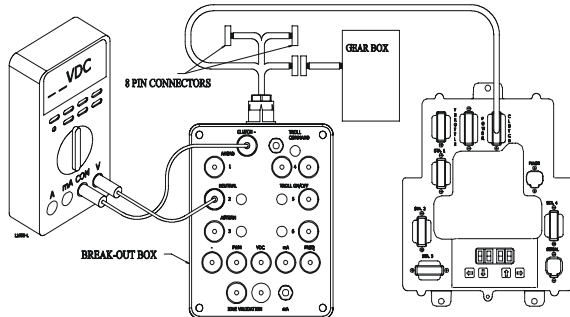

- B) Disconnect the Clutch Harness from the number 3 Processor connector/pigtail.
 C) Insert the Break-out Box between the number 3 Processor connector/pigtail and the Clutch Harness as shown in Figure 9:
 D) Turn power 'On' to the Processor and take command at any Remote Station with the Control Head lever in the Neutral/Idle position.
 E) The measurement on the Neutral Test Point should be 12 or 24 VDC, depending on the Solenoid's rating and the LED adjacent to the socket should be illuminated.

- F) Move the Control Head lever to the Ahead Detent position. The voltage should drop to 0 VDC in CruiseCommand systems and remain at 12 or 24 VDC in ClearCommand systems. The adjacent LED should go out in CruiseCommand systems and stay on in ClearCommand systems.

MM13927-3-1.2 Ahead Solenoid Testing

- A) Ensure power is removed from both the Processor and the Clutch Power Supply.

- B) Disconnect the Clutch Harness from the number 3 Processor connector/pigtail.

Figure 10: Clutch Connections Ahead Solenoid

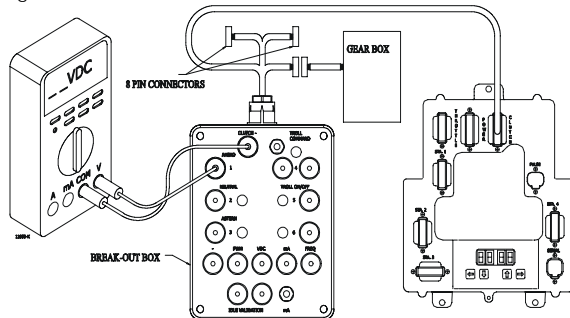

- C) Insert the Break-out Box between the number 3 Processor connector/pigtail and the Clutch Harness as shown in Figure 10:
 D) Set up the Multimeter to measure DC Volts and plug the black lead into the Break-out Box socket labeled "CLUTCH -" and the red lead into the socket labeled "AHEAD".
 E) Turn power 'On' to the Processor and take command at any Remote Station with the lever in the Neutral/Idle position.
 F) The measurement should be 0 VDC and the adjacent LED should not be lit.

- G) Position the Control Head lever into the Ahead detent. The measurement should be 12 or 24 VDC depending on the Ahead Solenoid's rating. The LED adjacent to the Ahead plug on the Break-out Box should be lit.

- H) Return the Control Head lever to the Neutral/Idle position.

MM13927-3-1.3 Astern Solenoid Testing

- A) Ensure power is removed from both the Processor and the Clutch Supply Power.

Figure 11: Clutch Connections Astern Solenoid

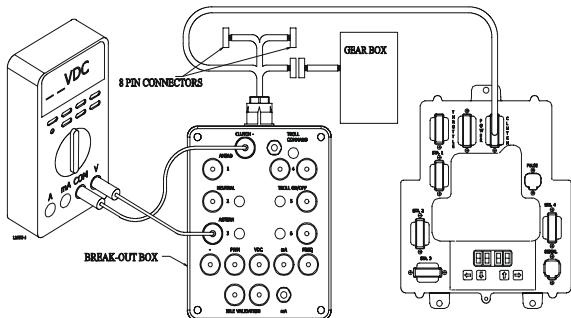

- B) Disconnect the Clutch Harness from the number 3 Processor connector/pigtail.
 C) Insert the Break-out Box between the number 3 Processor connector/pigtail and the Clutch Harness as shown in Figure 10:
 D) Set up the Multimeter to measure DC Volts and plug the black lead into the Break-out Box socket labeled "CLUTCH -" and the red lead into the socket labeled "ASTERN".
 E) Turn power 'On' to the Processor and take command at any Remote Station with the Control Head lever in the Neutral/Idle position.

- F) The measurement should be 0 VDC and the adjacent LED should not be lit.

- G) Position the Control Head lever into the Astern detent. The measurement should be 12 or 24 VDC depending on the Astern Solenoid's rating. The LED adjacent to the Astern plug on the Break-out Box should be lit. Return the Control Head lever to the Neutral/Idle position.



MM13927-4 TROLL PROCEDURES

MM13927-4-2 TESTING

MM13927-4-2.1 Troll On/Off Solenoid

- A) Ensure power is removed from both the Processor and the Clutch Power Supply.
- B) Disconnect the Clutch Harness from the number 3 Processor connector/pigtail.

Figure 12: Troll Connections Troll On/off Solenoid

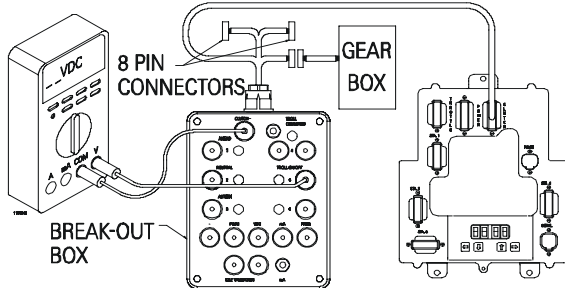

- C) Insert the Break-out Box between the number 3 Processor connector/pigtail and the Clutch Harness as shown in Figure 12:.
- D) Set up the Multimeter to measure DC Volts and connect the black lead to the socket labeled "CLUTCH -" and the red lead to the socket labeled "TROLL ON/OFF" as shown in Figure 12:.
- E) Turn power 'On' to the Processor and the Clutch Power Supply and take command at a Remote Station with the Control Head lever in the Neutral/Idle position.

- F) Depress the Transfer Button again for approximately 2 seconds until the red LED begins blinking at a fast rate (Troll Mode Indication).
- G) The measurement should be 0 VDC.
- H) Position the Control Head lever to the Ahead detent. The measurement should now be 12 or 24 VDC, depending on the Solenoid's rating.
- I) Position the Control Head lever further forward while monitoring the DC Voltmeter. The measurement should go from 12 or 24 VDC to 0 VDC at the same time the red LED on the Control Head becomes lit solid.

MM13927-4-2.2 Troll Command (Proportional Solenoid) Testing with Amp Meter

- A) Ensure power is removed from both the Processor and the Clutch Power Supply.
- B) Disconnect the Clutch Harness from the number 3 Processor connector/pigtail.

Figure 13: Troll Connections (Proportional Solenoid)

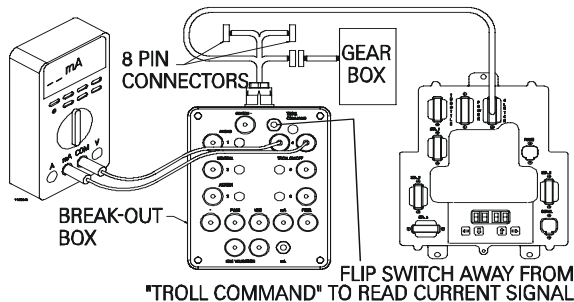

- C) Insert the Break-out Box between the number 3 Processor connector/pigtail and the Clutch Harness as shown in Figure 13:.
- D) Set up the Multimeter to measure (mA.) and connect the black lead to black socket and the red lead to the red socket labeled "TROLL COMMAND" as shown in Figure 13:.
- E) Turn power 'On' to the Processor and the Clutch Power Supply and take command at a Remote Station with the Control Head lever in the Neutral/Idle position.

- F) Depress the Transfer Button again for approximately 2 seconds until the red LED on the Control Head begins blinking at a fast rate (Troll Mode Indication).
- G) Flip switch away from "Troll Command" to read current through meter.
- H) Move the Control Head lever to the Ahead detent. The current measurement should be the correct value for minimum clutch pressure (shaft rotations). This value varies depending on the type of Marine Gear. Refer to the Literature provided with the Trolling Valve and the Processor for specifics.
- I) Slowly advance the Control Head lever while monitoring the current. The current should increase or decrease, depending on the Gear type, in proportion with the Control Head lever movement. Once again, refer to the Literature provided with the Trolling Valve and the Processor for specific values.
- J) Continue to move the Control Head lever forward until the red LED stops blinking (lit steady). The current should drop to 0 mA.



MM13927-5 2-SPEED TESTING

MM13927-5-3 2nd Gear Disengaged

- Ensure power is removed from the Processor.
- Disconnect the Clutch/2-Speed Harness from the number 3 Processor connector/pigtail.
- Insert the Break-out Box between the number 3 Processor connector/pigtail and the Clutch/2-Speed Harness as shown in Figure 14:.

Figure 14: 2-Speed Connections

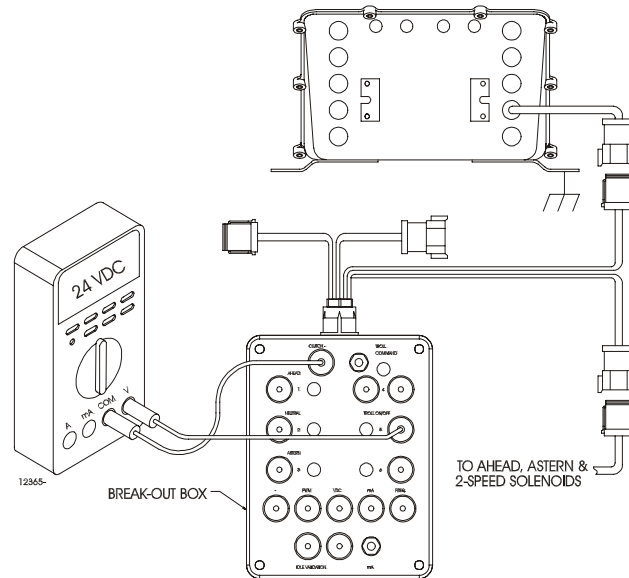

- Set up the Multimeter to measure DC Volts and connect the black lead to the socket labeled "CLUTCH -" and the red lead to the socket labeled "TROLL ON/OFF" as shown in Figure 14:.
- Turn power 'On' to the Processor and take command at any Remote Station.
- The voltage measurement should be approximate 0 VDC.

MM13927-5-4 2nd Gear Engaged

- Leave the Break-out Box and Multimeter in the same position as left in Section MM13927-5-3.
- Start the engine(s).
- Depress the Transfer Button while moving the lever(s) into the Ahead detent (red LED should be blinking, indicating Warm-up Mode).
- Continue to move both Control Head lever(s) forward until the RPM programmed for Function Code **U1** has been reached.
- The voltage measurement at the Multimeter should now be 12 or 24 VDC, depending on the Solenoid's rating.
- Return the Control Head levers to the Neutral/Idle position and shut down the engines.
- Turn power Off to the Processor(s).
- Unplug the Break-out Box from the Pigtail and Harness plugs and reconnect the Harness to the Pigtail.



MM13927-6 PARTS LIST

ZF Marine Electronics Part No.	Part Name
13927	Service Field Test unit (Break-out Box)
MM13927	Technical Manual
	Multimeter
14000	Test Control Head - Dual



ZF Marine Electronics, LLC
Mukilteo Plant

MMC-172, Rev. Z-R 3-05

Factory Authorized Sales & Service Centers - International

ARGENTINA

3205 Trimer S.A. (mail) PO Box 1772 Attn: Mariano Castroverde 1000 Buenos Aires, ARGENTINA (ship) Fray J.S.M. de Oro 2030.40 1425 Buenos Aires, ARGENTINA	Carlos Dorian Friedlander T: 54-11-4580-0444 F: 54-11-4580-0440
---	---

FINLAND

7655 Mastervolt Finland Powerduo Oy Haikankatu 2 FIN-21200, Raisio, FINLAND	Vesa Saarinen, Ari Bragge T: 358-2-433-9990 F: 358-2-435-0085
---	---

AUSTRALIA

6948 ZF Australia Pty. Ltd. (mail) Locked Bag 6305 Blacktown BC, NSW 2148 AUSTRALIA (ship) 14 Lidco Street Arndell Park, NSW 2148 AUSTRALIA	Rodney Lean T: +61 (0)2 9679 5555 F: +61 (0)2 9679 5500 mailbox@zf.com.au www.zf.com.au
--	---

FRANCE

2190 Seimi (mail) B.P. 30307 Brest Cedex, FRANCE 29603 (ship) Z.I.P. Du Moulin Blanc Rue Alain Colas 29200 Brest, FRANCE	Mr. L. Gautier T: 33 2 98 46 11 02 F: 33 2 98 43 37 49 info@seimi.com www.seimi.com
--	---

BRAZIL

7000 ZF do Brazil S.A. Avenida Conda Zeppelin, 1935 CEP 18103-0000 Soroc, BRAZIL	Antonio Tucunduva T: 5515-235-2301 F: 5515-235-2233
---	---

3590 Vidal Diffusion Marine (mail) B.P. 97 Toulon Cedex 9, FRANCE (ship) Z.I. Toulon -Est Toulon Cedex 9, FRANCE	David Elderkin T: 33 494 08 68 20 F: 33 494 08 26 59 d.elderkin@vidalmarine.com
--	--

CHINA

6953 ZF Shanghai Rep. Office Room 2504, Jiangnan Building No. 600 Luban Rd. Shanghai 200023, PR CHINA	Tang Zhou Qing T: 0086 21 6301 4338 F: 0086 21 6301 6449 M: 13901655780
---	--

GERMANY

7252 ADS Van Stigt Avelingen - West 30 NL-4202 MS Gorinchem, NETHERLANDS	Jan Hogenkamp T: +31 (0) 183 650000 F: +31 (0) 183 650001 vs@vanstigt.nl
--	---

DENMARK

7257 ZF Danmark APS Taastrupgaardsvej 8 - 10 DK-2630, Taastrup, DENMARK	Elisabeth Q. Sibbern T: +45 (0) 43 436243 F: +45 (0) 43 432643
--	--

7636 Otto Piening GMBH Piening Propeller AM Altendeich 83 Gluckstadt, 25348 GERMANY	Mathias Pein T: 49 4124 916812 M: 49 171 4853376 pein@piening-propeller.de
---	---

frank.kiessling@zf.com
www.zf-marine.com

GREECE

2386 Demetris Kyriazis
 Amaltheia T: 30210 25 88 985
 13 Papaflessa Str.
 143 43 N. Halkidona F: 30210 25 89 986
 Athens, GREECE

JAPAN

7253 Y. Ikeda
 ZF Marine Japan Co. Ltd. T: +81 (0) 3 5808 4521
 Fujikoshi Bldg. 1-10-11 Iriya Taito-ku
 Tokyo, 110-0013 F: +81 (0) 3 5808 4531
 JAPAN
 www.zf-marine.com

ICELAND

6525 Hrafn Sigurdasson, Johann Olafur Arsaelsson
 Merkur T: 354-568-1044
 Akralind 2
 201 Kopavogur, ICELAND F: 354-568-9958
 M: 354-863-0312
 hrafn@merkur.is
 olafur@murker.is

KOREA

1415 M.G. Song
 SE Jung Engineering Co. T: 82-51-415-0591
 #35-4 Namhangdong-1KA
 Yeongdogu F: 82-51-412-6361
 Pusan, KOREA
 sjeng88@kornet.net

IRELAND

7326 Adi Licence
 ZF Great Britain Ltd. T: 44-115-986-9211
 Abbeyfield Road, Lenton
 Nottingham, UNITED KINGDOM F: 44-115-986-9261
 NG7 2SX
 ENGLAND

NETHERLANDS (Holland)

7252 Jan Hogenkamp
 ADS / Van Stigt T: +31 (0) 183 650000
 Avelingen - West 30
 NL-4202 MS Gorinchem, F: +31 (0) 183 650001
 NETHERLANDS
 vs@vanstigt.nl

ITALY

7093 Antonio Renzetti, Alessandro Busetto
 SAIM SPA T: +39 02 488 531
 Via Donizetti, 9/11
 20090 Assago (MI), F: +39 02 45703070
 ITALY
 antonio.renzetti@saim-group.com
 alesandro.busetto@saim-group.com
 www.saim-group.com

5446 Dick Straathof
 Straathof Scheepselectra T: 31 321-382315
 Van de Plasschelaan 4
 8251 PG Dronten, NETHERLANDS F: 31 321-336151
 scheepselectra.com

MMC, CL, CR, MC

NEW ZEALAND

6477 Vittorio Rasera
 ZF Hurth T: 011-390-464-580-555
 38062 Arco (TN) Italy
 Via S. Andrea, 16, ITALY F: 011-390-464-580-544

6948 Rodney Lean
 ZF Australia Pty. LTD T: +61 (0)2 9679 5555
 (mail) Locked Bag 6305
 Blacktown BC, NSW, AUSTRALIA F: +61 (0)2 9679 5500
 2148
 (ship) 14 Lidco Street mailbox@zf.com.au
 Arndell Park, NSW, AUSTRALIA www.zf.com.au
 2148
 MMC, CL, CR

NORWAY

7244 ZF Padova S.p.A. T: 39-049-8299-550
 Via Panghe N. 48
 Selvazzano/Padova, ITALY I-35030 F: 39-049-8299-550
 info.zfpadova@zf.com
 www.zf-marine.com

7029 Karl Baumgart
 KGK Norge AS T: +47 22 884 680
 Casper Storms Vei 19
 Oslo, N-0664 F: +47 22 720 902
 NORWAY
 toma.wulff@zf-group.com
 www.zf-group.no
 MMC, CL, CR

RUSSIA

7313
ZF Transmissia 000
Suite 313
71, Marata Street
St. Petersburg, RUSSIA 191119

T: 7 (812) 324 54 72
F: 7 (812) 140 18 15

zf@sp.ru

SWEDEN

7234
KG Knutsson AB
Transmissionsdivisionen
Hammarbracken 8
S-191 81 Sollentuna, SWEDEN

Karl-Henry Pragsten
T: +46 (0) 8 923 312
F: +46 (0) 8 929 599

zf-marine@kgk.se

SCOTLAND

7326
ZF Great Britain Ltd.
Abbeyfield Road, Lenton
Nottingham, UNITED KINGDOM
NG7 2SX
ENGLAND

Adi Licence
T: 44-115-986-9211
F: 44-115-986-9261

adi.licence@zf-group.it

SWITZERLAND

2419
Marine Parts Heimgartner
Pfaffikerstrasse 6
CH-8604 Volketswil
Zurich, SWITZERLAND

Rolf Heimgartner
T: 41 1997 4090
F: 41 1997 4094

info@marineparts.ch
www.marineparts.ch

SINGAPORE

157
Mammoth Enterprises Pte. Ltd.
(mail) PO Box 283
Siglap Post Office, SINGAPORE
914503
(ship) 6-A Waringin Park
, SINGAPORE 416320

Steven Wee
T: 65 6 44-88266
F: 65 6 44-89800

mament@singnet.com.sg

TAIWAN

5355
Asia Diesel Electric Corp.
20th Floor
34 Min Chuan 1st Road
Kaohsiung, R.O.C. TAIWAN

Mike Ou
T: 886 7 333 1191
F: 886 7 334 6808

7045
ZF South East Asia Pte.
11 Tuas Drive 1
Singapore, 638678
Rep. of SINGAPORE

Daniel Poone
T: +65 (0) 8 610177
F: +65 (0) 6861 9173

daniel.poon@zf-group.com.sg
www.zf-marine.com

THAILAND

7283
ZF Thailand Co. Ltd
159/33 Soi Vipawasee 64
Vipawadee-Rangsit Road
Laksi, Bangkok, Bangkok 10210
THAILAND

Reungpoj V
T: +66 2 521 6520
F: +66 2 521 6523

terrapong@zf-thai.co.th
www.zf-marine.com

SOUTH AFRICA

7261
ZF South Africa (Pty) Ltd
(mail) PO Box 2098
Kempton Park, 1620 SOUTH
AFRICA
(ship) C/O Barlows Power Systems
Cnr. Peter Barlow and Kasselss Vlei
Rd

T: 27 11 453 1818
F: 27 11 453 7506

TURKEY

7223
Niveko Makina Dis Ticaret Kollektif Sti
Lorenz Severin Moritz Wwinstabl ve
Ortaklan
Hasan Yelmen Cad No.15
TR-34957 Tuzla -, Istanbul Deri
Serbest Bolgesi TURKEY

Mr. Georg Weinstabl
T: 90 212 287 27 80
F: 90 212 287 65 71

georg@niveko.com

SPAIN

5556
ZF Espana, S.A.
Avda. Fuentermar, 11
Coslada (Madrid), 28820
SPAIN

Juanma Raposa
T: +34 (91) 4852699
F: +34 (91) 6733931

www.zf-marine.com

U.A.E.

7030
ZF Middle East, LLC
(mail) PO Box 26093
Sharjah, U.A.E.
(ship) #502 Golden Tower Building
Sharjah,
U.A.E
MMC, CL, MC

M. Narasimhan (NARSI)
T: 971-6-574-7074
T:
harasimhan.manian@zf.com
F: 971-6-574-7174
zfmarine@emirates.net.ae
narsi@zf-marine.com
www.zf-marine.com

UNITED KINGDOM (England)

6932 Atlantis Marine Power Ltd. Western Wood Way Langage Science Park Plymouth, Devon,, Plymouth PL7 5BG ENGLAND	Richard Dix T: 44 1752 208810 F: 44 1752 208811 richard@atlantismarine.co.uk www.atlantismarine.co.uk
---	---

USA

ZF Marine Electronics, LLC 12125 Harbour Reach Drive, Suite B Mukilteo, WA 98275 USA	T: 425-583-1900 F: 425-493-1569 www.zf-marine.com
MMC, CL,CR, MC	

6427 ZF Marine LLC - US Headquarters 3131 SW 42nd Street Fort Lauderdale, FL 33312 USA	Kelly Friedenberg T: 954-581-4040 F: 954-581-4078 www.zf-marine.com
--	--

ZF Marine LLC - Gulf Coast Facility 161 James Drive West Suite 120 St. Rose, LA 70087 USA	Randy Tredinich, Marc Kloor T: 504-443-0501 F: 504-443-0504 www.zf-marine.com
--	--

ZF Marine LLC - West Coast 12125 Harbour Reach Drive, Suite B Mukilteo, WA 98275 USA	Kevin Zwicker, Keith Kaelberer T: 425-583-1900 F: 425-493-1579 www.zf-marine.com
---	---

ZF Marine LLC - Annapolis 301 Pier One Road Suite 102 Stevensville, MD 21666 USA	Stafford Barringer, Jeff Carter T: 410-604-3320 www.zf-marine.com
---	---

ZF Marine LLC - Chicago 777 Hickory Hill Drive Vernon Hills, IL 60061 USA	Jimmy Wong, Steve Vu T: 847-478-6868 F: 847-478-6789 www.zf-marine.com
--	---

USA

ZF Marine LLC - Irvine Service Center 1350 Reynolds Ave., Suite #110 Irvine, CA 92614	Cherie McAdams T: 949-251-0140 F: 949-251-0150 cherie.mcadams@zf.com
---	---

ZF Marine LLC - North Carolina 1350 Sensation Weigh Beaufort, NC 28516 USA	Phil Organ T: 252-504-3700 F: 252-504-3773 www.zf-marine.com
---	---

ZF Marine LLC - Rhode Island 1 Mastead Drive Warwick, RI 02886 USA	John Shea, Gil Bashaw T: 401-541-9014 F: 401-541-7223 www.zf-marine.com
---	--



ZF Marine Electronics, LLC
Mukilteo Plant

MMC-151, Rev. Z-Z-I 9-05

Factory Authorized Service Centers – North America

Factory Training Indicated by: MMC = MicroCommander,
CL = ClearCommand, MC = MasterCommand, CR = CruiseCommand.

ALASKA

5005 Alaska Professional Marine (mail) PO Box 32083 Juneau, AK 99803 (ship) 1900 Fritz Cove Road Juneau, AK 99803	Keith Stephens T: 907-789-9740 F: 907-789-0054
--	--

ALASKA

5395 Rainbow Glacier Company PO Box 821 Haines, AK 99827	Karl Johnson T: 907-766-2218 F: 907-766-2585
---	--

6950 Anchor Electric 5362 Commercial Blvd. Juneau, AK 99801	William Shattenberg T: 907-780-3690 F: 907-780-3692 bill@anchoralaska.com
--	--

2104 Sitka Electronics Lab 232 Katlian Avenue Sitka, AK 99835	Mel Holmgren, John Teas, Eric Holmgren T: 907-747-6570 F: 907-747-6170 jteas@gci.net mnbh@ptialaska.net
--	---

399 Kachemak Gear Shed 3625 eAST eND rOAD Homer, AK 99603	Butch T: 907-235-7993 F: 907-235-7233
--	---

5396 Spaulding Sports Supply 2017 Badger Road North Pole, AK 99708	Steve Spaulding T: 907-488-6998 T: 907-488-5242 F: 907-488-6385
---	--

5394 Ketchikan Area Timber and Marine Supply 2547 Tongass Avenue Ketchikan, AK 99901	Ken Perry T: 907-225-6644 F: 907-247-0644
---	---

2108 Sutliff's Hardware Inc PO Box 1157 Kodiak, AK 99615	Gene Lorenson T: 907-486-5797 F: 907-486-4977
---	---

2111 Piston & Rudder (mail) PO Box 1308 Petersburg, AK 99833 (ship) 101 A Harbor Way Petersburg, AK 99833	Mike Luhr T: 907-772-4240 F: 907-772-4239 pisrud@gci.com
--	---

3184 The Bay Company 431 Front Street Wrangell, AK 99929	Chet Powell, Mike Ottesen T: 907-874-3340 F: 907-874-2592
---	---

ALASKA

2900
Timber & Marine
2547 Tongass Ave.
Ketchikan, AK 99001

T: 907-225-6644
F: 907-225-0644

3652
Wikan Enterprises, Inc.
(mail) PO Box 929
Petersburg, AK 99833
(ship) 103 Dock Street
Petersburg, AK 99833

John Wikan
T: 907-772-4155
F: 907-772-4153
wikanent@alaska.com

ARKANSAS

6337
Dreamchaser Houseboats
(mail) PO Box 356
Mt. Ida, AR 71957
(ship) 60 Marina Drive
Mt. Ida, AR 71957

Tiny Joe
T: 870-867-3480
F: 870-867-2665

MMC

ARIZONA

Aramark/Lake Powell Resorts & Marinas
PO Box 1597
Page, AZ 86040

Mark Suttie
T: 928-645-1186
F: 928-645-1101
suttie-mark@aramark.com

MMC

7048
Desert Recreation, Inc.
315 Long Avenue
Bullhead City, AZ 86429

Jim Ronnie, Jim Prestin, Mark Munsinger
T: 928-754-4391
F: 928-754-3335
desrec@ctaz.com

MMC

5935
Donn's Boat Shop, Inc.
(mail) PO Box 3826
Page, AZ 86040
(ship) 486 Haul Road
Page, AZ 86040

Donn DeVore
T: 928-645-0313
F: 928-645-0323
boatfxr@donnsboatshop.com

MMC

ARIZONA

Mobile Marine Repair, Inc.
PO Box 2988
Page, AZ 86040

Steve Ringleman
T: 928-645-1406
F: 928-645-1406

MMC

2488
Old West Marine Service
(mail) Po Box 4798
Page, AZ 86040
(ship) 1002 Vista
Page, AZ 86040

Steve Adamczyk, Steve Ringleman, Jason Giffen
T: 928-645-2705
F: 928-645-2542
oldwest@oldwestmarine.com

MMC

2331
Skipperliner
(mail) PO Box 3058
Page, AZ 86040
(ship) 550 Haul Road
Page, AZ 86040

Jay Phelps, Jerry Apalategui
T: 928-645-2444
F: 928-645-5753

Skipperliner - Lake Pleasant
40202 N. 87th Avenue
Peoria, AZ 85382

Mike Montgomery, Glenn Carson
T: 928-501-2444
F: 928-501-2443
phelps@skipperliner.com

MMC

2381
Tony's Dri-Doc & Marine
(mail) PO Box 897
Page, AZ 86040
(ship) 902 Hemlock
Page, AZ 86040

Tony Ferrando
T: 928-645-2732
F: 928-645-5237

MMC

CANADA - British Columbia

5139
Canoe Cove Marina
2300 Canoe Cove Road
Sidney, BC V8L 3X9

Mike Lewis, Basil Drinnan
T: 250-656-5566
F: 250-655-7197

*

5031
Coast Electric
1852 Sloan Avenue
Prince Rupert, BC V8J 4B5

Don Pederson
T: 250-627-8531
F: 250-627-8531
coast@citytel.net

CANADA - British Columbia

2949 Bill McArthur
 McArthur Enterprises Inc. T: 250-883-4640
 #326 - 129 Burnett Road
 Victoria, BC V9B 4P6
 bGmcarthur@uniserve.com
 MMC, CL

CALIFORNIA

2393 Roger Adams
 A to Z Marine Services T: 619-224-1606
 1453 Rosecrans Street
 San Diego, CA 92106 F: 619-226-0496
 M: 619-921-6697
 radams@atozmarine.net
 MMC, CL

7543 Tony Greyshock, Rick Sullivan, John Sage
 Blue Marlin Group T: 949-642-0882
 624 Terminal Way
 Costa Mesa, CA 92627 F: 949-642-0419
 MMC, CL

2498 Marc Hermann, Dan Teske
 Channel Coast Marine T: 805-985-0220
 2949 W. 5th Street
 Oxnard, CA 93030 F: 805-985-7707
 M: 805-432-8256
 MMC, CL

6805 Chris Schjoth
 Chris Marine T: 530-275-3097
 14265 Holiday Road
 Redding, CA 96003 F: 530-275-3096
 MMC

2181 Ron Easley, Roberto Reyes
 Easley Marine Inc. T: 949-631-0142
 1635 Superior Avenue, Unit 9
 Costa Mesa, CA 92627 F: 949-631-0219
 easleyac@pacbell.net
 MMC, CL

2733 Joe Donatini, Mark Egon, Larry Scroggins
 Johnson Hicks Marine Inc. T: 831-475-3383
 333 C Lake Avenue
 Santa Cruz, CA 95062 F: 831-475-1498
 jhme6@cs.com
 MMC

CALIFORNIA

2472 Mike Han, Kip Fatout
 Jones Valley & Shasta Lake Resorts T: 530-275-7950
 22300 Jones Valley Marina Road
 Redding, CA 96003 F: 530-275-3523
 *

7337 Roger Nunez, Manuel Lopez
 Reliable Marine Electronics T: 510-885-0525
 1925 Lafayette Street
 Alameda, CA 94501 F: 510-885-0526
 radarrog@aol.com
 MMC, CR

7084 Brian Scoles
 Scoles Marine Services T: 909-678-6171
 615 LeHarve Avenue
 Lake Elsinore, CA 92530-5386 F: 909-678-7807
 CL

Robert Sherrill, Caleb Linn
 Sherrill's Marine Service T: 310-510-1610
 PO Box 2112
 Avalon, CA 90704 F: 310-510-1352
 MMC

2456 Tony Travis
 Ship Shape Marine T: 510-272-9695
 909 Marina Village Pkwy, #186
 Alameda, CA 94501 F: 510-419-0792
 M: 510-206-0420
 shipmarine@aol.com
 MMC, CL

7661 Henry Bramhall
 Trans Pacific Distributors T: 707-426-6670
 1941 Walters Court
 Fairfield, CA 94533 F: 707-426-0206

CONNECTICUT

2131 Greg Schroder
 Mystic River Marina T: 860-536-3936
 36 Quarry Road
 Mystic, CT 06355 F: 860-536-0713
 *

FLORIDA

3387 Mike Handschmann
 ATM Marine, Inc. T: 305-251-7547
 18730 Lenaire Drive
 Miami, FL 33157 F: 305-238-6800
 M: 305-926-3813
 atmmarine@bellsouth.net
 MMC, CL

3259 Dave Gillen
 Dave Gillen Diesel T: 954-927-6500
 811 N.E. 3rd Street
 Dania Beach, FL 33004 F: 954-927-6090
 MMC, CL

6170 Shannon Neville, Nadja Dilger, David Laschomb
 Lost River Marine T: 772-283-1154
 490 SW Salerno Road
 Stuart, FL 34997 F: 772-283-9550
 info@lostrivermarine.com
 www.lostrivermarine.com

5742 Melody Dodamead
 Sea Wiz T: 305-289-4044
 (mail) PO Box 501396
 Marathon, FL 33050 F: 305-289-3090
 (ship) 8025 Gulf Stream Blvd. M: 305-481-0440
 Marathon, FL 33050
 *

6622 Pam Lenzion
 St. Augustine Marine T: 904-824-4394
 404 South Riberia Street
 St. Augustine, FL 32084 F: 904-824-9755
 MMC

5987 Enrique Giner
 Yacht Electric Corporation T: 305-638-9777
 7770 NW 53rd St
 Miami, FL 33166 F: 305-994-7575
 MMC, CL

3353 Jim Monroe, Lee Moore
 Yacht Equipment and Parts T: 954-463-7222
 3330 SW 3rd. Avenue T: 800-349-9224
 Ft. Lauderdale, FL 33315 F: 954-463-9009
 M: Jim 954-868-1840
 jmonroe@bowboat.com
 MMC, CL

GEORGIA

7587 Bill Willingham
 Maricom Electronics T: 912-354-4542
 2911 River Drive
 Thunderbolt, GA 31404 F: 912-356-1249

3013 Painter Stevenson
 Mobile Marine T: 770-965-1864
 PO Box 1239
 Buford, GA 30515 F: 770-965-8446
 M: 770-480-3805
 sst3485@aol.com
 MMC

5946 Tim McNeil
 On Site Marine Service T: 770-614-0106
 (mail) 2835 Still Meadows Way
 Buford, GA 30519 F: 770-271-1909
 (ship) 6109 Holiday Road M: 404-867-1235
 Buford, GA 30518

HAWAII

3157 Mike Rand
 Mike Rand T: 808-960-1493
 75-1027 Henry Street, PMB 164
 Kailua Kona, HI 96740 F: 808-325-1209

IOWA

6863 Greg Stirn
 S & S Rentals, Inc. T: 563-538-4454
 (mail) BOX 389 T: 563-538-4135
 Lansing, IA 52151 F: 563-538-4454
 (ship) 990 South Front Street
 Lansing, IA 52151

KENTUCKY

2270 Jamie Donahue
 Pluckebaum Custom Boats, Inc. T: 502-228-0111
 1231 State Road 1793
 Prospect, KY 40059 F: 502-228-4767

LOUISIANA

3401
Air Marine Radio
2421 8th Street
Harvey, LA 70058

Bob Albrecht
T: 504-362-1226

F: 504-368-2668

(owners personal e-mail)
rjaflys@aol.com

NORTH CAROLINA

2861
Marine Control Systems
76 May Apple Lane
Franklin, NC 28734

Gary Sorensen
T: 828-369-7572

F: 828-369-7572
M: 828-508-1701

MMC marinecontrolsys.com

MASSACHUSETTS

5596
Niemic Marine
173 Popes Island
New Bedford, MA 02740

Martin Niemic
T: 508-997-7390

F: 508-997-8978

MMC, CL

NEW JERSEY

3195
Martek Electronics
47 South Shore Rd
Marmora, NJ 08223

Charles Hewitt
T: 609-390-3355

F: 609-390-0849
M: 609-517-5505

*

MARYLAND

5906
Hinckley Yachts Svcs
(mail) PO Box 369
Oxford, MD 21654
(ship) Bank Street
Oxford, MD 21654

Ben Sheets
T: 410-226-5113

F: 410-226-5602

MMC

5597
South Jersey Offshore Electric
900 Ocean Dr.
Cape May, NJ 08204

Dave Wrigley
T: 609-884-6400

F: 609-884-2995

NEVADA

2530
Middle River Electronics
233C Nanticoke Road
Baltimore, MD 21221

Eric R. Carl, John Weaver, Darren Weaver
T: 410-687-6474

F: 410-687-3353

MMC

7050
A & M Marine
1630 Foothill Drive
Boulder City, NV 89005

Jim Bell, Scott Wall
T: 702-293-1321

F: 702-293-5896

anmmarine@aol.com

MMC

NORTH CAROLINA

3601
Demann Marine Power
107 Bryan Road
Wilmington, NC 28412

Tom Demann
T: 910-791-6222

F: 910-791-7056

2291
Callville Bay Resort & Marina
HCR 30 Box 100
Las Vegas, NV 89124

Carl Ward
T: 702-565-4813

F: 702-566-9899

MMC

5380
Griffin Marine Inc
(mail) PO Box 458
Wanchese, NC 27981
(ship) 898 Harbor Road
Wanchese, NC 27981

Don Griffin, Don Griffin Jr., Casey Carr
T: 252-473-1422

F: 252-473-4654
M: 252-305-1173

griffinmarine@mindspring.com

MMC, CL

7206
Overton Beach Marina
HC30 Box 7
Overton, NV 89040

Chad Ewing, Paul Chandler
T: 702-394-4040

F: 702-394-4142

MMC

NEW YORK

2066 Dennis McGowan
 Den-Mac Sales T: 631-842-8967
 8 Ramick Drive W.
 Amityville, NY 11701 F: 631-842-5274

"Sales Only"

Lion Yacht Service Bob Lew
 P O Box 5378 T: 516-528-8062
 Bay Shore, NY 11706 F: 631-666-1379

bob@lionyacht.com

"Service Only"

2260 Mark Jarboe
 Montauk Marine Basin, Inc. T: 631-668-5900
 (mail) PO Box 610
 Montauk, NY 11954 F: 631-668-5659
 (ship) 426 Westlake Drive
 Montauk, NY 11954

OREGON

6671 Jeff Dykes
 Cook Engine & Co. T: 503-289-8466
 503 NE Tomahawk Island Drive
 Portland, OR 97217 F: 503-286-2836

sales@cookengine.com

544 Terry Wheeler, Scott Graf, Laurie Wheeler
 Curry Marine T: 541-265-7955
 (mail) PO Box 610
 Newport, OR 97365 F: 541-265-4226
 (ship) 1211 SE Bay Blvd.
 Newport, OR 97365

6474 Bill Elderkin, Paul Kepford
 George's Marine Electric T: 541-888-5209
 PO Box 5530
 Charleston, OR 97420 F: 541-888-9557

6873 paul Wilson
 Sells Marine T: 503-285-3838
 1111 NE Marine Dr.
 Portland, OR 97211

PENNSYLVANIA

5272 Joe Loughran, James Moorhead
 Airline Hydraulics Corporation T: 215-638-4700
 Expressway 95 Business Center
 Bensalem, PA 19020 F: 215-638-1707

MMC, CL

PUERTO RICO

5852 David Davila
 Yacht Specialty T: 787-755-4406
 RR#2 Box 693
 San Juan, PR 00926 F: 787-755-4406
 M: 787-307-7518

MMC

SOUTH CAROLINA

3196 Tony Smircic
 MacKay Communications T: 843-766-3856
 1369 B Ashley River Rd
 Charleston, SC 29407 F: 843-571-5301

TENNESSEE

5391 R.S. Simpson
 Simpson Marine Electronics T: 865-966-8481
 (mail) PO Box 22213
 Knoxville, TN 37933 F: 865-966-9707
 (ship) 665 Chapel Point Lane
 Knoxville, TN 37922

MMC

TEXAS

2266 Dennis Osborne, Danny Baldwin
 Lakewood Yacht Service T: 281-474-2885
 (mail) PO Box 536
 Seabrook, TX 77586 F: 281-474-2885
 (ship) 2301 Nasa Road 1
 Seabrook, TX 77586
 jjohnstone@lakewoodyachtservice.com

UTAH

Mark Grahn
 Aramark - Halls Crossing T: 435-684-7019
 PO Box 5101
 Lake Powell, UT 84533 F: 435-684-7027

UTAH

Bullfrog Boat Shop PO Box 4055 Lake Powell, UT 84533	Tami Luckesen T: 435-684-3018 F: 435-684-3005
--	---

MMC

5401 Offshore Marina, Inc. (mail) PO Box 330330 Lake Powell, UT 84533 (ship) Hwy 276, Mile Marker 30 Lake Powell, UT 84533	Darryl Hickson, Chris Pear T: 435-788-2142 Ext. 11 F: 435-788-2303 offshoremarinaLP@aol.com
---	--

MMC, CL, CR, MC

VIRGINIA

3304 Bluewater Yacht Sales, Inc. 25 Marina Road Hampton, VA 23669	Craig Messick T: 757-723-0793 F: 757-723-3320
--	---

MMC

WASHINGTON

6186 Anacortes Yacht Charters 2415 T Avenue, #112 Anacortes, WA 98221	T: 360-293-4555 F: 360-293-6683
--	--

2967 Complete Controls 9306 NE 7th Street Vancouver, WA 98664	Jim Palmer T: 360-904-7525 F: 360-254-7846 M: 360-904-7525 jpalmer1@attbi.com
--	---

MMC

6662 Components Unlimited 17315 Olympic Place Mt. Vernon, WA 98274	Bill Mol T: 360-336-9698 F: 360-424-8950 M: 206-915-0712
---	---

*

WASHINGTON

2410 Harris Electric Inc. 4020 23rd Ave. W. Seattle, WA 98199	Keith Ozby T: 206-282-8080 F: 206-284-5521
--	--

*

2273 Islands Marine Center, Inc. (mail) PO Box 88 Lopez Island, WA 98261 (ship) Fishermens Bay Road Lopez Island, WA 98261	Ron Meng T: 360-468-3377 F: 360-468-2283
---	--

2008 LeClerq Marine Construction 1080 W. Ewing Seattle, WA 98119	Chuck Knapp T: 206-283-8555 F: 206-286-1726
---	---

*

6626 Marine Servicenter, Inc. - ANA 2417 "T" Ave. Anacortes, WA 98221	Skip Dassler T: 360-293-8200 F: 360-293-9648
--	--

1261 Maritime Fabrications (mail) PO Box 816 LaConner, WA 98257 (ship) 920 West Pearle Jensen Way LaConner, WA 98257	T: 360-466-3629 F: 360-466-3632
---	--

3494 North Harbor Diesel Inc. 720 30th Street Anacortes, WA 98221	Dave Williams, Mike Curran T: 360-293-5551 F: 360-293-0728 nharbor@fidalgo.net
--	---

MMC, CL

5443 Ocean Alexander Marine Center 1115 N. Northlake Way Seattle, WA 98103	Scott Morris T: 206-547-1395 F: 206-547-3789
---	--

*

WASHINGTON

7344 Pinnacle Marine Services 160 Cascade Place #229 Burlington, WA 98223	Dave Hanson T: 360-404-2063 F: 360-404-2064 M: 360-920-1630 pinanmar@aol.com
--	--

MMC, CL, CR, MC

2383 Puget Sound Yacht Service 9611 - 146th Place SE Snohomish, WA 98296	Paul Waits T: 206-660-3630 F: 425-483-0710 psyachtservice@aol.com
---	--

*

2729 Radar Marine Electronics 16 Squalicum Mall Blvd. Bellingham, WA 98225	Bill Pulse T: 360-733-2012 F: 360-733-2383
---	--

6669 Reliance Marine Electronics 2436 NW 61St Seattle, WA 98107	Randy Widen T: 206-781-1105 F: 206-789-9775 rme@wolfenet.com
--	---

* Here from July - April (See also AK)

3506 Yacht Care Inc. 2601 West Marina Place, Ste. K Seattle, WA 98199	Jim Brown T: 206-285-2600 F: 206-285-2610
--	---

APPENDIX C



Drawing 11748, Single Screw, Two Stations

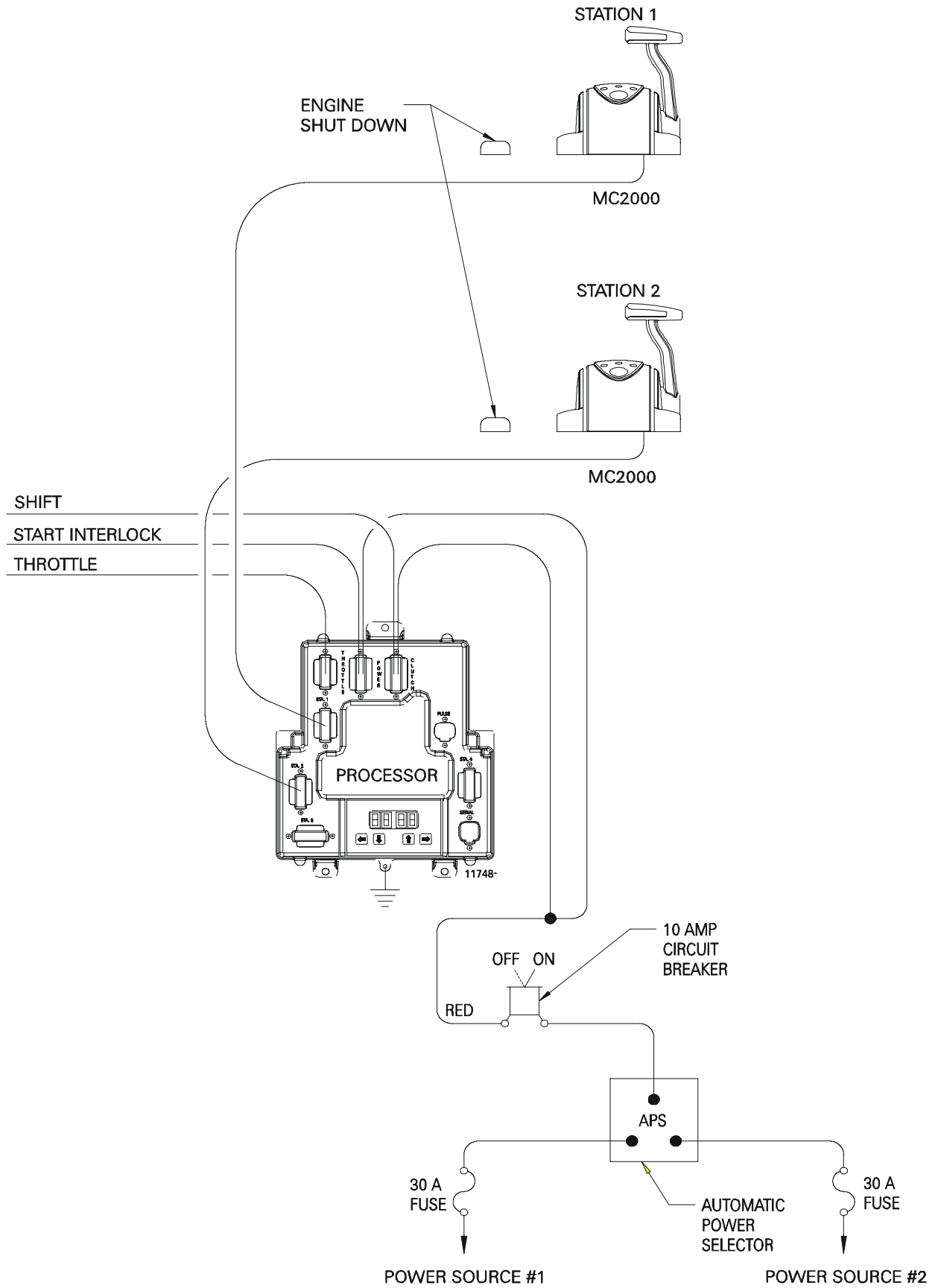





Drawing 11746, Single Screw, Two Pluggable Stations

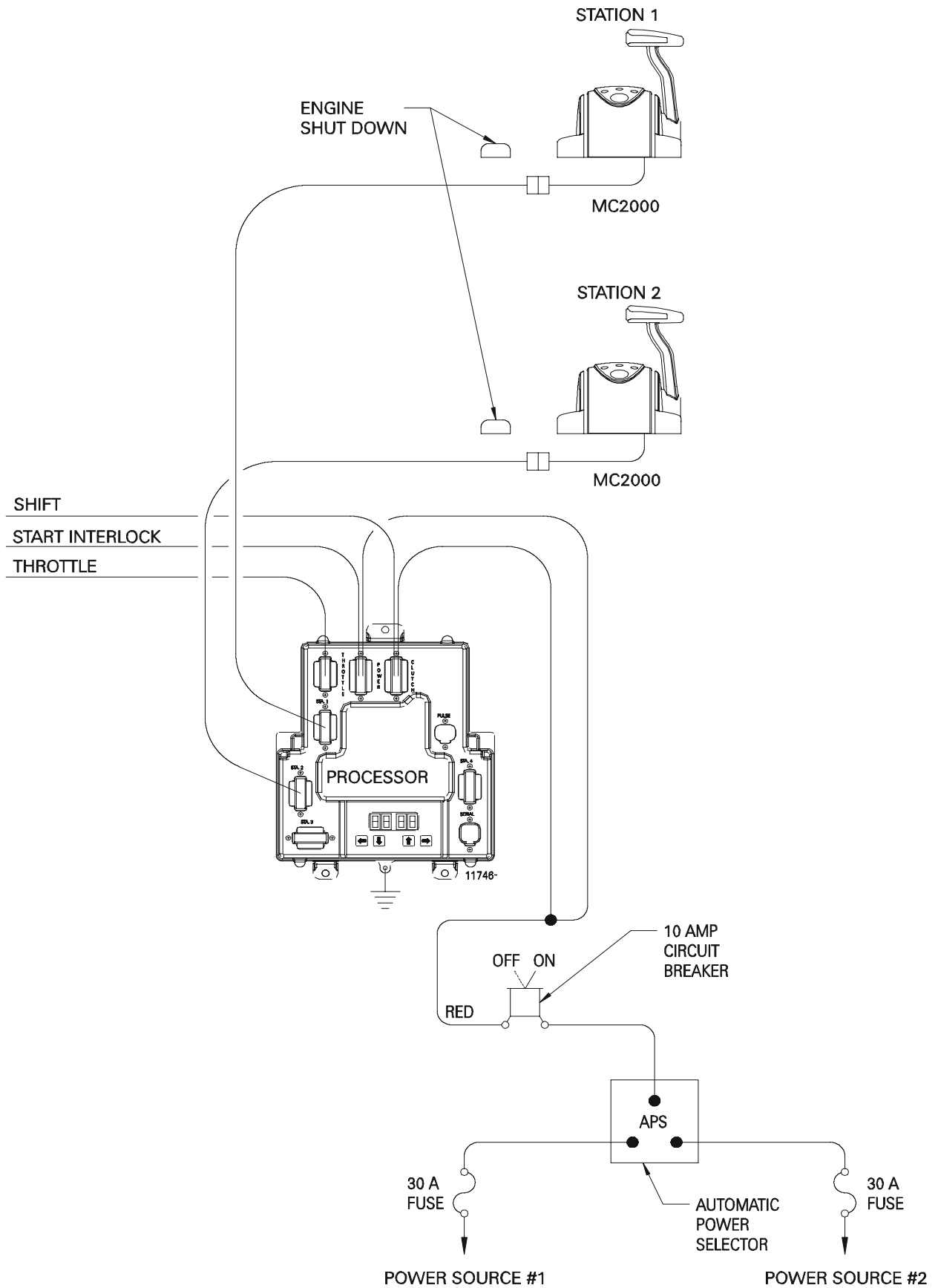





Drawing 11747, Twin Screw, Two Stations

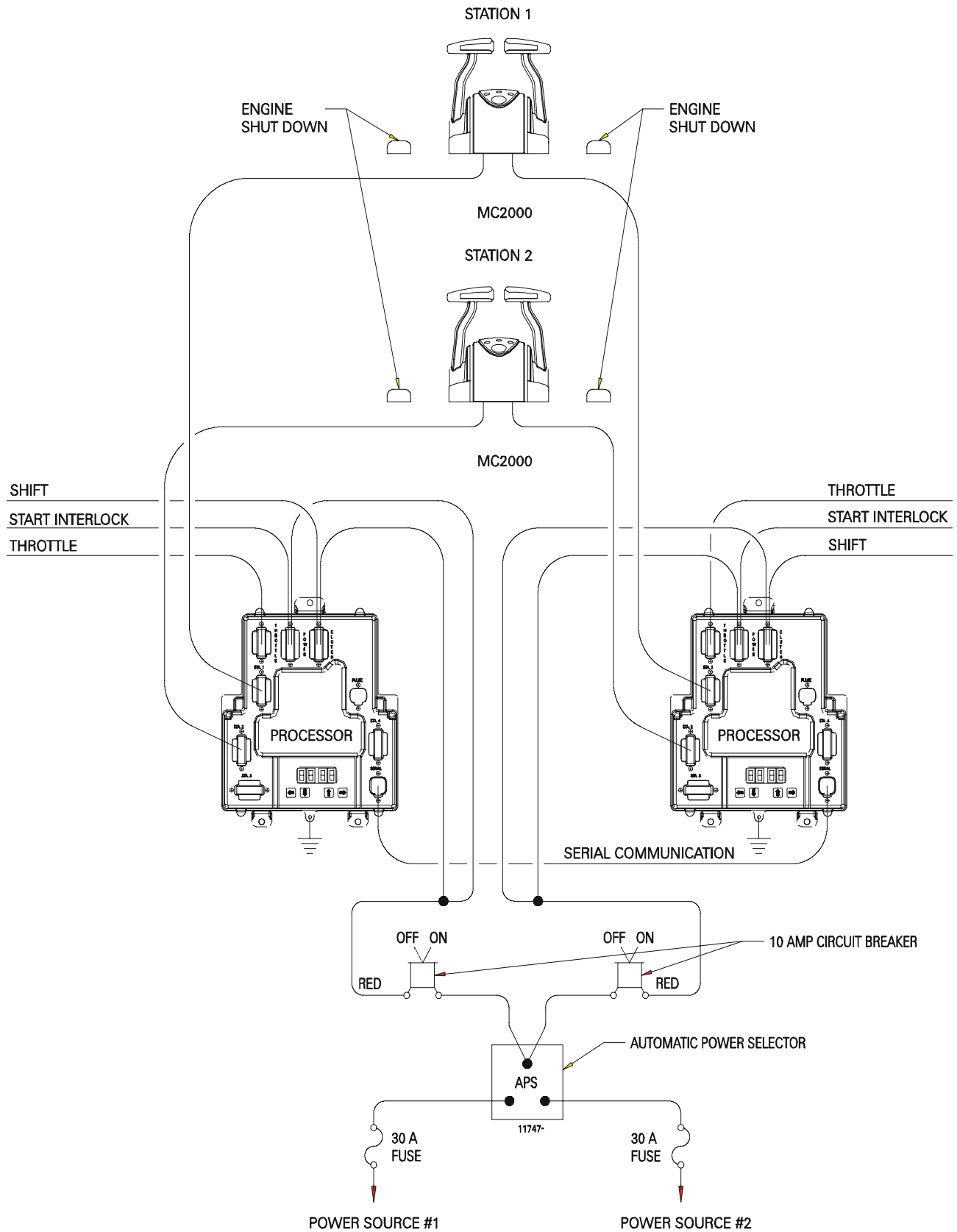





Drawing 11745, Twin Screw, Two Pluggable Stations

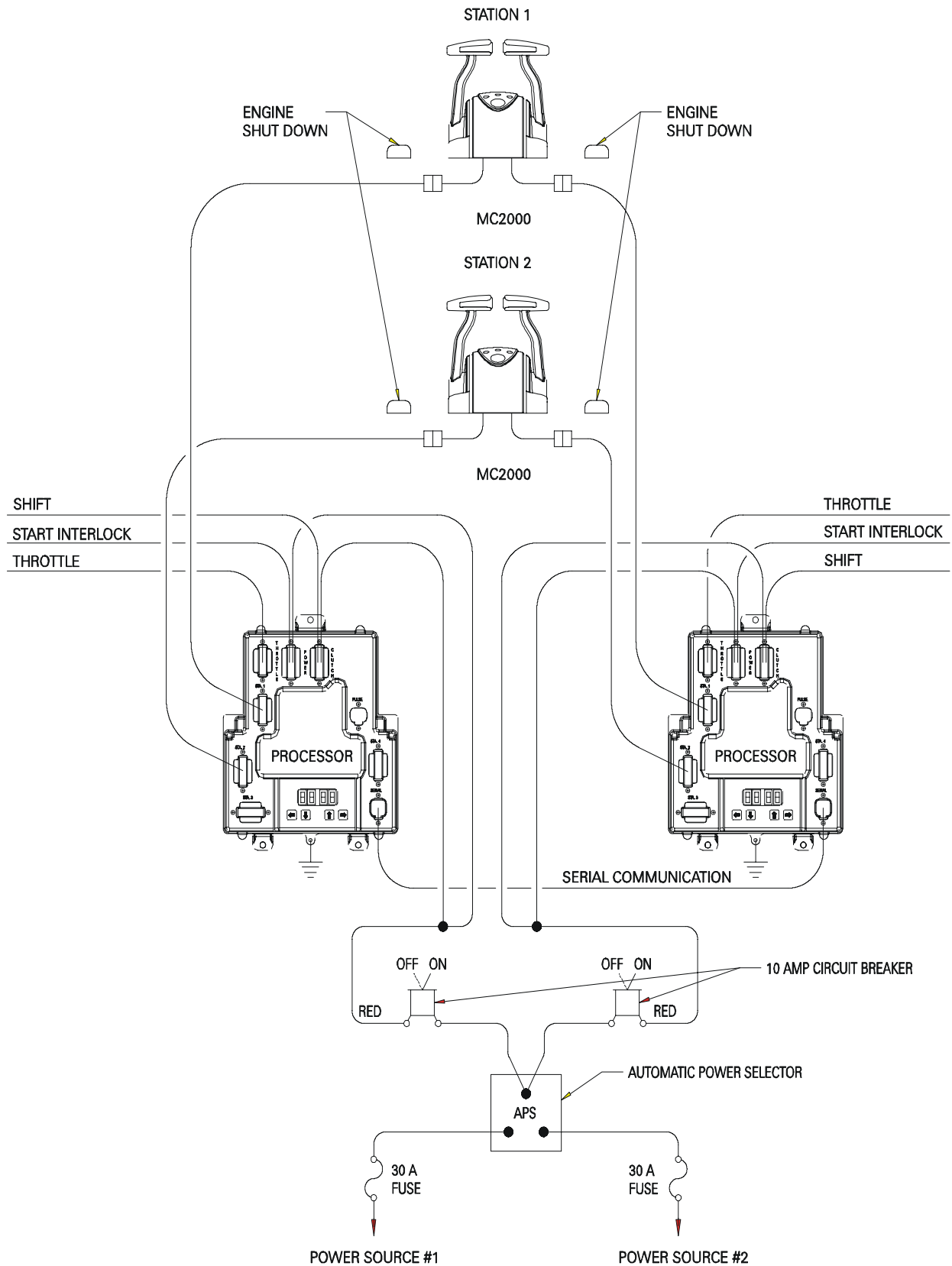



Drawing 12230-1 Power Option #1

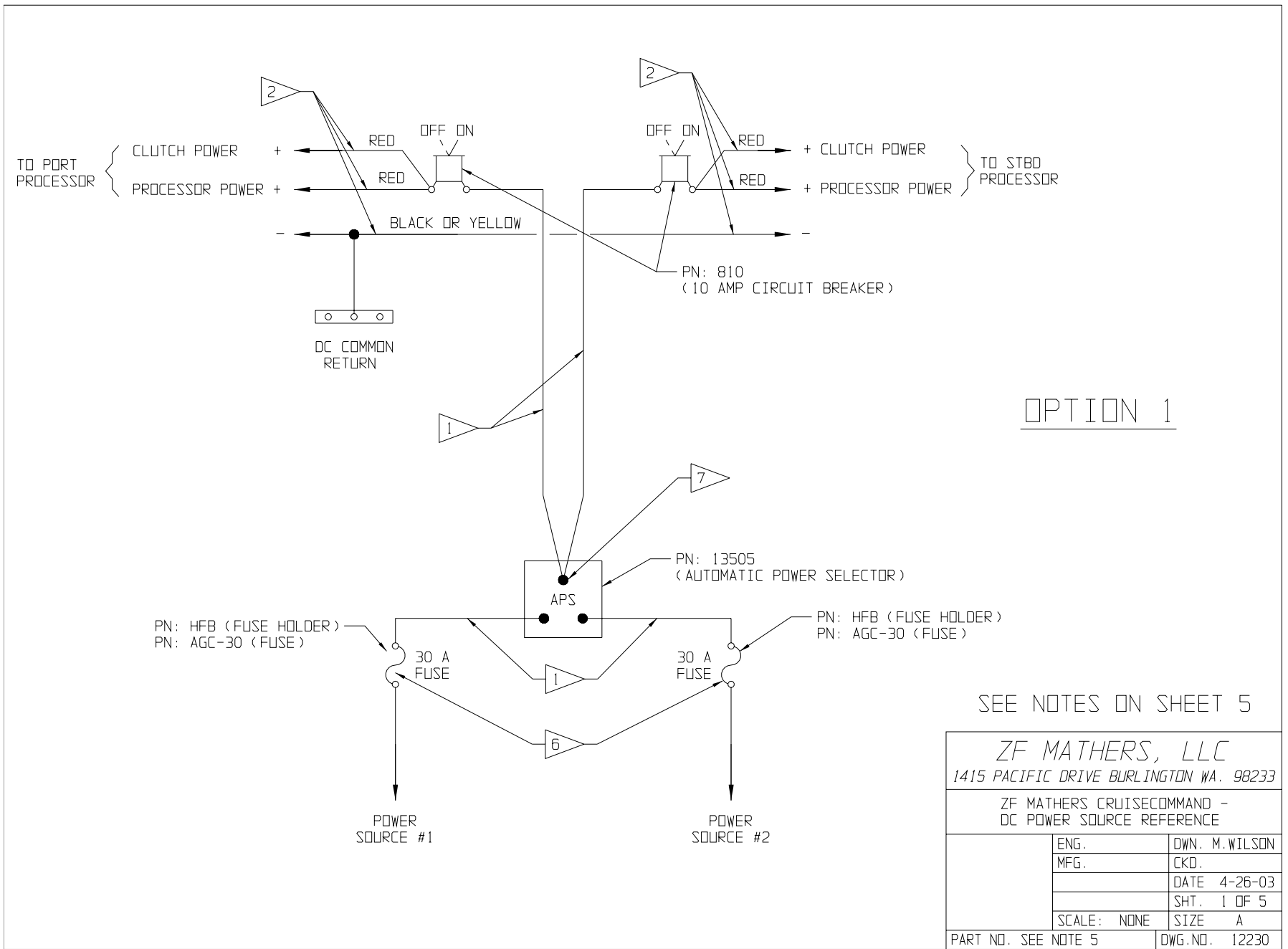

ZF MATHERS, LLC		
1415 PACIFIC DRIVE BURLINGTON WA. 98233		
ZF MATHERS CRUISECOMMAND - DC POWER SOURCE REFERENCE		
ENG.	DWN.	M. WILSON
MFG.	CKD.	
	DATE	4-26-03
	SHT.	1 OF 5
SCALE:	NONE	SIZE A
PART NO. SEE NOTE 5	DWG. NO. 12230	

Drawing 12230-2 Power Option #2

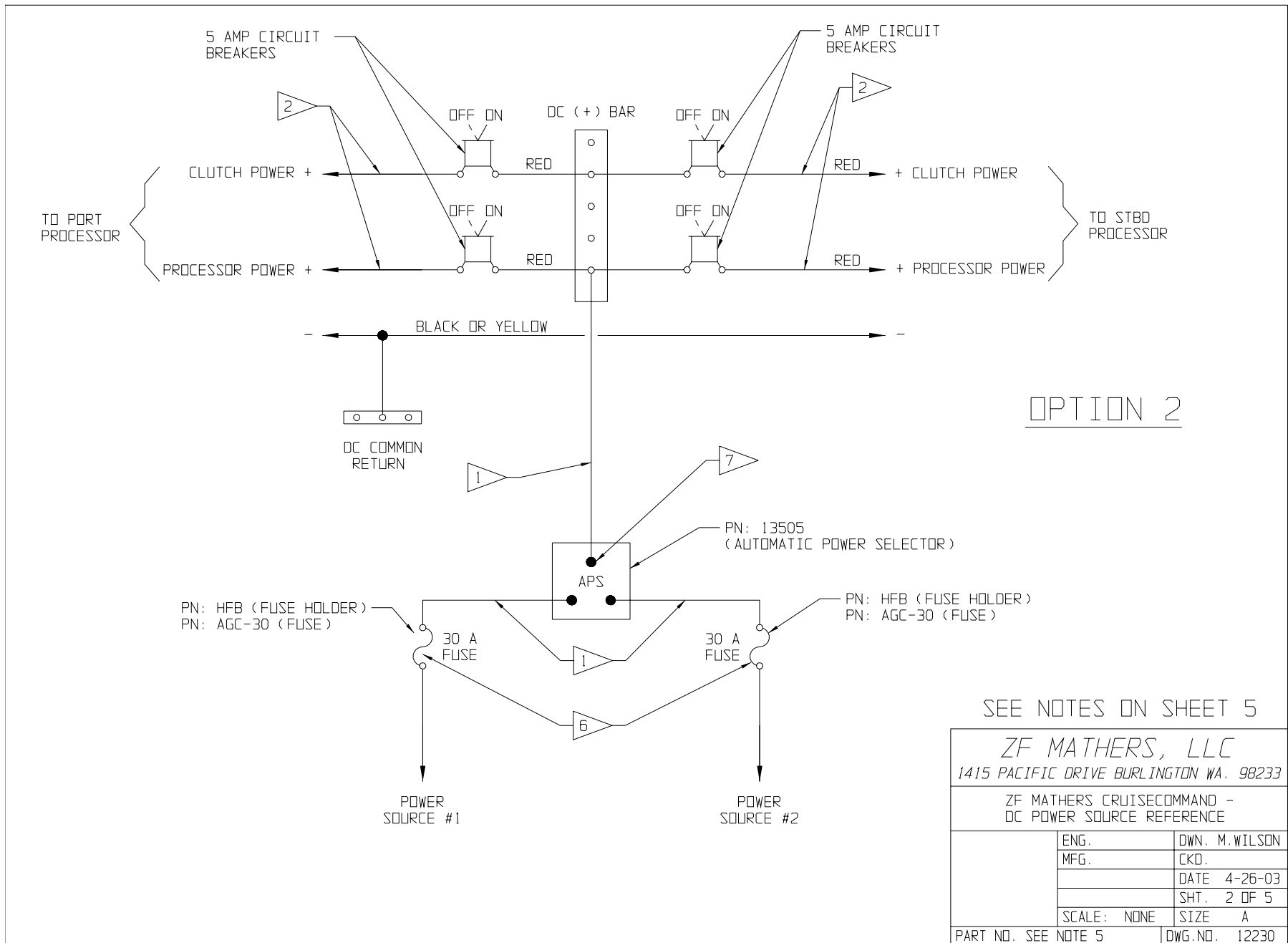

Drawing 12230-3 Power Option #3

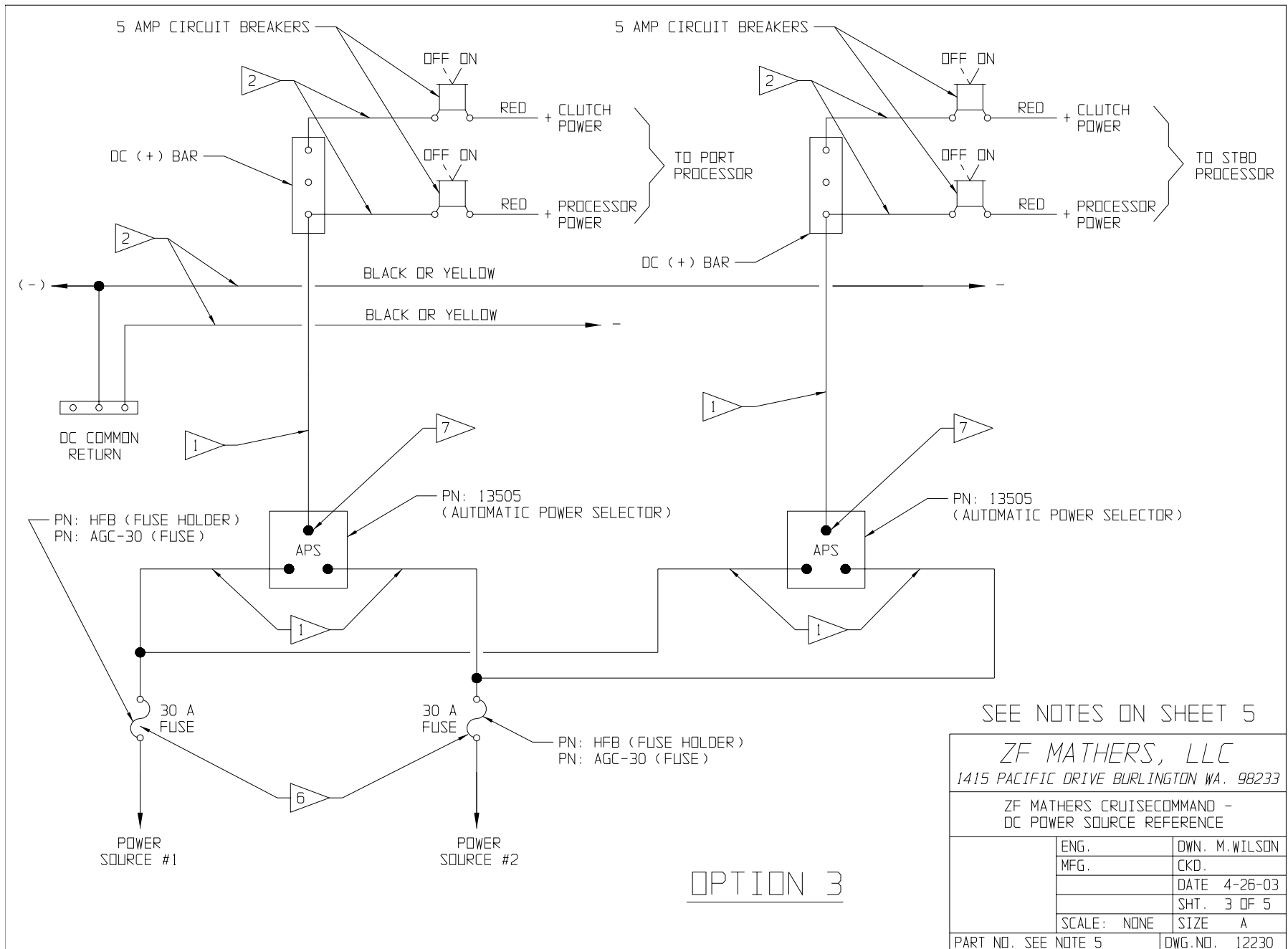

Drawing 12230-4 Power Option #4

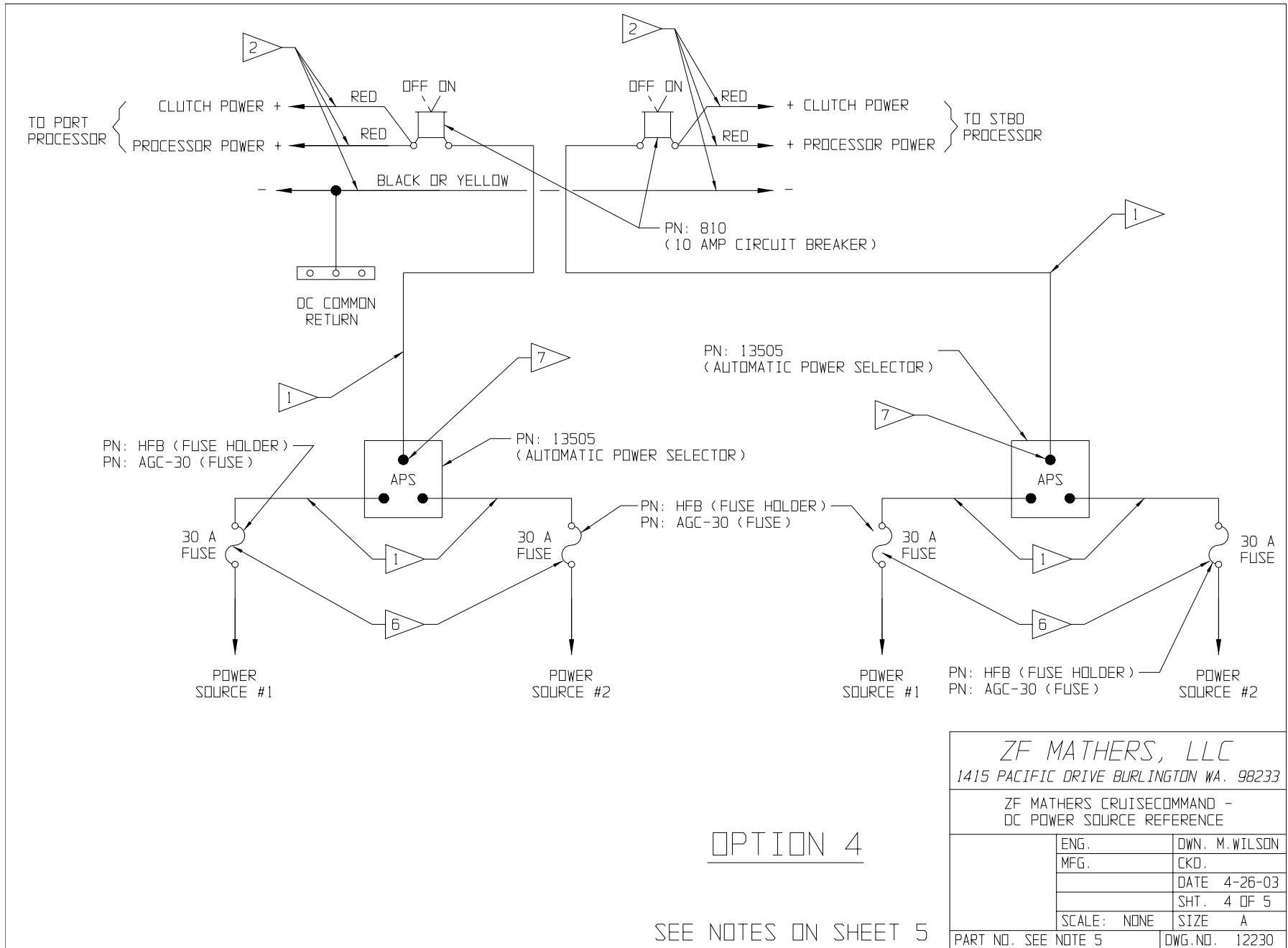

OPTION 4

SEE NOTES ON SHEET 5

ZF MATHERS, LLC		
1415 PACIFIC DRIVE BURLINGTON WA. 98233		
ZF MATHERS CRUISECOMMAND - DC POWER SOURCE REFERENCE		
ENG.	DWN.	M. WILSON
MFG.	CKD.	
	DATE	4-26-03
	SHT.	4 OF 5
SCALE: NONE	SIZE	A
PART NO. SEE NOTE 5	DWG. NO. 12230	

Drawing 12230-5 Power Option #5

NOTES:

1 WIRE SIZE (REF ABYC E9.15.9 10%)

12VDC POWER SYSTEMS:

0-15'	(0-4,6M)	12 AWG (#4 METRIC EQUIVALENT)
15'-25'	(4,6-7,6M)	10 AWG (#6 " ")
25'-40'	(7,6-12,2M)	8 AWG (#10 " ")
40'-70'	(12,2-21,3M)	6 AWG (#16 " ")

24VDC POWER SYSTEMS:

0-20'	(0-6,1M)	14 AWG (#2,5 METRIC EQUIVALENT)
20'-30'	(6,1-9,1M)	12 AWG (#4 " ")
30'-50'	(9,1-15,2M)	10 AWG (#6 " ")
50'-80'	(15,2-24,3M)	8 AWG (#10 " ")

2 WIRE SIZE (RECOMMENDED TWISTED PAIR)

12VDC POWER SYSTEMS:

0-20'	(0-6,1M)	14 AWG (#2,5 METRIC EQUIVALENT)
20'-30'	(6,1-9,1M)	12 AWG (#4 " ")

24VDC POWER SYSTEMS:

0-40'	(0-12,2M)	14 AWG (#2,5 METRIC EQUIVALENT)
40'-65'	(12,2-19,8M)	12 AWG (#4 " ")

3. APS OUTPUT IS STRICTLY FOR ZF MATHERS CONTROLS.

4. POWER SOURCES MAY BE 12 OR 24 VOLTS DC.

5. SINGLE SCREW KIT - PN: 13983.

PN: 13505 (AUTOMATIC POWER SELECTOR)	QTY 1
PN: 810 (10 AMP CIRCUIT BREAKER)	QTY 1
PN: AGC-30 (30 AMP FUSE)	QTY 2
PN: HFB (FUSE HOLDER)	QTY 2

TWIN SCREW KIT - PN: 13984.

PN: 13505 (AUTOMATIC POWER SELECTOR)	QTY 1
PN: 810 (10AMP CIRCUIT BREAKER)	QTY 2
PN: AGC-30 (30 AMP FUSE)	QTY 2
PN: HFB (FUSE HOLDER)	QTY 2

6 MAXIMUM WIRE SIZE ALLOWED IN FUSEHOLDER IS 12 AWG. IF A LARGER WIRE SIZE IS REQUIRED FOR INSTALLATION, THE CUSTOMER SHALL PROVIDE AN APPROPRIATE FUSE AND FUSE HOLDER. (SUGGESTED MANUFACTURER BLUE SEA SYSTEMS, MAXI FUSE BLOCK SERIES).

7 SEE FIGURE 1 BELOW FOR THE SUGGESTED HARDWARE STACK FOR SYSTEMS UTILIZING MULTIPLE OUTPUTS FROM THE PN: 13505 (AUTOMATIC POWER SELECTOR).

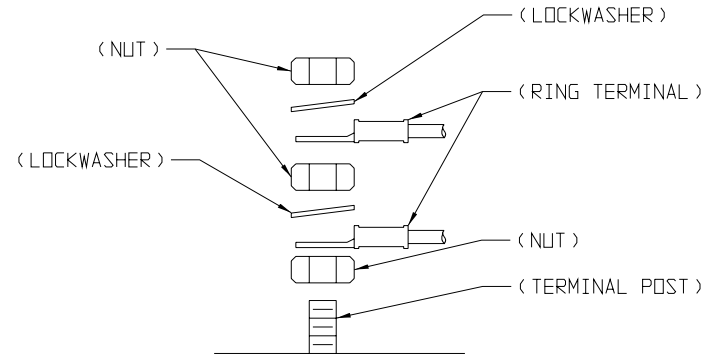

FIGURE 1

ZF MATHERS, LLC	
1415 PACIFIC DRIVE BURLINGTON WA. 98233	
ZF MATHERS CRUISECOMMAND - DC POWER SOURCE REFERENCE	
ENG.	DWN. M. WILSON
MFG.	CKD.
QA.	DATE 4-26-03
	SHT. 5 OF 5
SCALE: NONE	SIZE A
PART NO. SEE NOTE 5	DWG. NO. 12230

